

# Brief operation manual for compact hydraulic power packs type HC

acc. to pamphlet D 7900



**Attention:** The power pack has to be connected to the system and main by a craftsman who knows and observes all relevant industrial standards.

## 1. Electrical data

**Note:** For operation with 1 ~ 230V AC, see sect. 4

Type	Nom. voltage and connection U <sub>N</sub> (V)	Mains frequency f (Hz)	Nom. performance P <sub>N</sub> (kW)	Revolutions n <sub>nom</sub> (min <sup>-1</sup> )	Nom. current I <sub>N</sub> (A)	Start current ratio I <sub>A</sub> / I <sub>N</sub>	Power factor cos φ	Insulat. material classification
<b>HC 14</b>	400/230 YΔ	50	0.18	1380	0.60 / 1.05	2.9	0.69	B
	460/265 YΔ	60	0.21	1650	0.55 / 0.95	3	0.72	
	500 Y 1)	50	0.18	1370	0.54	2.7	0.7	
<b>HC 12</b>	400/230 YΔ	50	0.25	2860	0.65 / 1.15	4	0.78	B
	460/265 YΔ 2)	60	0.3	3420	0.6 / 1.04	4	0.8	
	500 Y 1)	50	0.25	2840	0.54	4	0.8	
<b>HCW 14</b>	230 ⊥	50	0.18 3)	1390	1.8	2.8	0.86	B
<b>HCW 12</b>	230 ⊥	50	0.25 3)	2700	2.2	3.2	0.95	
<b>HC 24</b>	400/230 YΔ	50	0.55	1390	1.6 / 2.8	4.4	0.75	B
	460/265 YΔ	60	0.66	1670	1.5 / 2.5	5	0.8	
	500 Y 1)	50	0.55	1410	0.84	4	0.74	
<b>HC 22</b>	400/230 YΔ	50	0.75	2680	1.75 / 3.0	5.7	0.85	B
	460/265 YΔ 2)	60	0.9	3216	1.65 / 2.95	6	0.85	
	500 Y 1)	50	0.75	2700	1.4	5	0.85	
<b>HCW 24</b>	230 ⊥	50	0.37	1350	3.0	3	0.95	F
<b>HCW 22</b>	230 ⊥	50	0.55	2720	4.1	3.5	0.96	
<b>HC 34</b>	400/230 YΔ	50	1.1	1410	2.7 / 4.7	5.3	0.81	F
	460/265 YΔ	60	1.3	1690	2.8 / 4.8	5	0.83	B
	500 Y 1)	50	1.1	1410	2.2	5.3	0.81	
<b>HC 32</b>	400/230 YΔ	50	1.5	2850	3.3 / 5.7	6.3	0.85	F
	460/265 YΔ 2)	60	1.8	3430	3.4 / 5.9	5.8	0.88	B
	500 Y 1)	50	1.5	2850	2.7	6.3	0.85	
<b>HCW 34</b>	230 ⊥	50	0.75 3)	1370	5.5	2.4	0.93	F
<b>HC 44</b>	400/230 YΔ	50	2.2	1405	4.8 / 8.3	4.8	0.85	B
	460/265 YΔ	60	2.6	1725	4.9 / 8.5	4.9	0.87	
<b>HC 42</b>	400/230 YΔ	50	2.2	2870	4.5 / 7.8	4.5	0.88	B
	460/265 YΔ 2)	60	2.6	3444	4.5 / 7.8	4.5	0.89	
<b>HC 48</b>	400/230 YΔ	50	3	1410	6.6 / 11.5	6.6	0.84	B
	460/265 YΔ	60	3.6	1730	6.6 / 11.5	6.6	0.86	
<b>HC 46</b>	400/230 YΔ	50	3	2880	6.2 / 10.5	6.2	0.87	B
	460/265 YΔ 2)	60	3.6	3456	6.2 / 10.8	6.2	0.88	
<b>HCW 44</b>	230 ⊥	50	1.5	1375	10.1	3.3	0.94	B
	110 ⊥	60	1.5	1650	21	3.3	0.94	

Protection classification: IP54

Production class 1: It is recommended to use a RCCB (residual current circuit breaker)

Permissible voltage ranges

Mains 50 Hz: ±10% U<sub>N</sub> (conforming IEC 38)

Mains 60 Hz: ±5% U<sub>N</sub>

Reduced supply voltage will cause a performance drop (Δ reduced p<sub>max</sub>). in Kauf zu nehmen.

Guideline:  $p_{oper.} \approx 0.85 p_{max} \cdot \frac{U_{actual}}{U_N}$

Example:  $\frac{U_{actual}}{U_N} = \frac{400V}{460V}$  60 Hz  
 $p_{oper. max} = 0.85 p_{max} \cdot \frac{400V}{460V} \approx 0.7 p_{max}$

1) Fixed connection at the winding head.

2) The hydraulic power unit may be connected to mains with a frequency of 60 Hz, but the resulting revolution rating of approx. 3400 rpm is rather high. This can not only lead to increased running noise, but also to suction problems with small piston diameters. Therefore it is recommended that the viscosity of the pressure fluid during operation shouldn't exceed 160 to 200 mm<sup>2</sup>/s.

3) Nom. lay-out S3-40%

## 2. Motor current (guideline)

These hydraulic power units are intended for intermittent service S3. It is therefore possible to load the motor above its nominal performance rating for short periods. This will cause the power consumption to rise on 140 to 160% of  $I_N$  during max. operation pressure ( $p_{oper.} = p_{max}$ ).

### Version for 3-phase mains type HC...

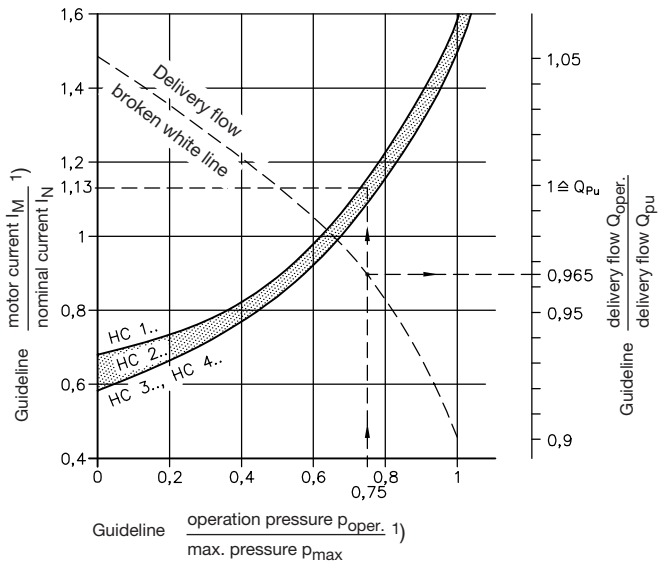

### Version for radial piston pump

Type	Coding <sup>2)</sup> and max. pressure bar (figures in brackets)									
HC 14	<b>0,2</b> (700)	<b>0,31</b> (640)	<b>0,44</b> (440)	<b>0,61</b> (325)	<b>0,87</b> (250)	<b>1,05</b> (195)				
HC 12	<b>0,4</b> (600)	<b>0,65</b> (380)	<b>0,94</b> (265)	<b>1,28</b> (200)	<b>1,71</b> (150)	<b>2,14</b> (120)				
HC 24	<b>0,27</b> (700)	<b>0,42</b> (700)	<b>0,64</b> (700)	<b>0,81</b> (600)	<b>1,1</b> (460)	<b>1,35</b> (370)				
	<b>0,46</b> (700)	<b>0,7</b> (700)	<b>1,08</b> (495)	<b>1,39</b> (360)	<b>1,77</b> (275)	<b>2,27</b> (220)				
HC 22	<b>0,52</b> (700)	<b>0,82</b> (700)	<b>1,17</b> (540)	<b>1,58</b> (400)	<b>2,06</b> (300)	<b>2,61</b> (240)				
	<b>0,89</b> (700)	<b>1,36</b> (470)	<b>2,09</b> (325)	<b>2,68</b> (240)	<b>3,41</b> (180)	<b>4,41</b> (145)				
HC 34	<b>0,9</b> (700)	<b>1,25</b> (700)	<b>1,5</b> (610)	<b>2,5</b> (390)	<b>3,6</b> (270)	<b>4,3</b> (230)	<b>5,1</b> (200)	<b>5,6</b> (170)	<b>6,5</b> (150)	
HC 32	<b>1,75</b> (700)	<b>2,44</b> (510)	<b>3,0</b> (400)	<b>4,9</b> (250)	<b>7,1</b> (175)	<b>8,5</b> (150)	<b>10,2</b> (130)	<b>11,1</b> (110)	<b>12,9</b> (95)	
HC 44	<b>0,9</b> (700)	<b>1,25</b> (700)	<b>1,5</b> (700)	<b>2,5</b> (670)	<b>3,6</b> (460)	<b>4,3</b> (400)	<b>5,1</b> (340)	<b>5,6</b> (300)	<b>6,5</b> (260)	
	<b>1,8</b> (700)	<b>2,45</b> (680)	<b>3,2</b> (520)	<b>5,0</b> (330)	<b>7,2</b> (230)	<b>8,6</b> (200)	<b>9,9</b> (170)	<b>11,5</b> (150)	<b>13,1</b> (130)	
HC 42	<b>1,75</b> (700)	<b>2,44</b> (700)	<b>3,0</b> (700)	<b>4,9</b> (460)	<b>7,1</b> (320)	<b>8,5</b> (270)	<b>10,2</b> (240)	<b>11,1</b> (210)	<b>12,9</b> (180)	
	<b>3,5</b> (650)	<b>4,85</b> (470)	<b>6,55</b> (360)	<b>10,3</b> (230)	<b>14,8</b> (160)	<b>17,25</b> (135)	<b>20,1</b> (120)	<b>23,1</b> (---)	<b>26</b> (---)	
HC 48	<b>0,9</b> (700)	<b>1,25</b> (700)	<b>1,5</b> (700)	<b>2,5</b> (700)	<b>3,6</b> (490)	<b>4,3</b> (420)	<b>5,1</b> (360)	<b>5,6</b> (315)	<b>6,5</b> (275)	
	<b>1,8</b> (700)	<b>2,45</b> (700)	<b>3,2</b> (700)	<b>5,0</b> (500)	<b>7,2</b> (350)	<b>8,6</b> (300)	<b>9,9</b> (250)	<b>11,5</b> (220)	<b>13,1</b> (200)	
HC 46	<b>1,75</b> (700)	<b>2,44</b> (700)	<b>3,0</b> (700)	<b>4,9</b> (700)	<b>7,1</b> (490)	<b>8,5</b> (420)	<b>10,2</b> (360)	<b>11,1</b> (315)	<b>12,9</b> (275)	
	<b>3,5</b> (700)	<b>4,85</b> (700)	<b>6,55</b> (590)	<b>10,3</b> (380)	<b>14,8</b> (260)	<b>17,25</b> (220)	<b>20,1</b> (190)	<b>23,1</b> (---)	<b>26</b> (---)	
HCW 14	<b>0,2</b> (700)	<b>0,31</b> (540)	<b>0,44</b> (380)	<b>0,61</b> (280)	<b>0,87</b> (210)	<b>1,5</b> (170)				
HCW 12	<b>0,4</b> (660)	<b>0,65</b> (420)	<b>0,94</b> (300)	<b>1,28</b> (215)	<b>1,71</b> (165)	<b>2,14</b> (130)				
HCW 24	<b>0,27</b> (700)	<b>0,42</b> (700)	<b>0,64</b> (600)	<b>0,81</b> (440)	<b>1,1</b> (340)	<b>1,35</b> (270)				
	<b>0,46</b> (700)	<b>0,7</b> (520)	<b>1,08</b> (360)	<b>1,39</b> (265)	<b>1,77</b> (200)	<b>2,27</b> (160)				
HCW 22	<b>0,52</b> (700)	<b>0,82</b> (530)	<b>1,17</b> (370)	<b>1,58</b> (270)	<b>2,06</b> (210)	<b>2,61</b> (160)				
	<b>0,89</b> (500)	<b>1,36</b> (315)	<b>2,09</b> (220)	<b>2,68</b> (160)	<b>3,41</b> (120)	<b>4,41</b> (95)				
HCW 34	<b>0,9</b> (700)	<b>1,25</b> (520)	<b>1,5</b> (400)	<b>2,5</b> (250)	<b>3,6</b> (180)	<b>4,3</b> (150)	<b>5,1</b> (130)	<b>5,6</b> (115)	<b>6,5</b> (100)	
HCW 44	<b>0,9</b> (700)	<b>1,25</b> (700)	<b>1,5</b> (700)	<b>2,5</b> (460)	<b>3,6</b> (320)	<b>4,3</b> (270)	<b>5,1</b> (230)	<b>5,6</b> (200)	<b>6,5</b> (180)	
	<b>1,8</b> (630)	<b>2,45</b> (460)	<b>3,2</b> (350)	<b>5,0</b> (220)	<b>7,2</b> (150)	<b>8,6</b> (130)	<b>9,9</b> (110)	<b>11,5</b> (100)	<b>13,1</b> (80)	

### Version for 1-phase mains type HCW...

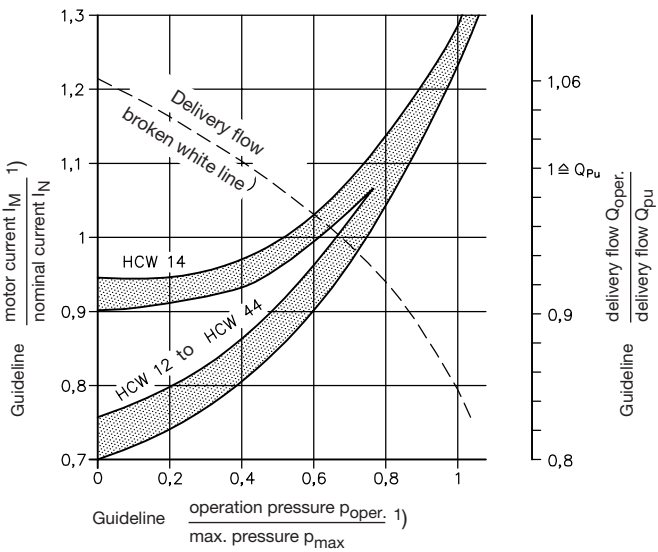

1) There is a reduced current ratio, divergently to the curve below, for types listed in the adjoining table at operating pressure ( $p_{max} = 700$  bar). This is caused by the high motor output.

Current ratio:  $\frac{I_M}{I_N}$  or  $\left(\frac{I_M}{I_{ref.}}\right)$

Type	$\frac{I_M}{I_N} \left(\frac{I_M}{I_{ref.}}\right)$
HC 24/0,27	approx. 0.9
HC 24/0,42	approx. 1.0
HC 22/0,52	approx. 1.1
HCW 24/0,27	approx. 0.85

with  $C_B = 16 \mu F$  ( $C_B = 24 \mu F$  not necessary)

HC 42..	approx. 2.1
HC 46..	approx. 2.5

2) The coding corresponds roughly to the pump delivery with a mains frequency of 50 Hz, but it will be 20% higher with mains 60 Hz.

Version for gear pump

Type	Coding <sup>1)</sup> and max. pressure bar (figures in brackets)					
HC 24	<b>Z 0,5</b> (150)	<b>Z 1,0</b> (150)	<b>Z 1,8</b> (150)			
HC 22	<b>Z 0,5</b> (150)	<b>Z 1,0</b> (150)	<b>Z 1,8</b> (150)			
HC 34	<b>Z 2,0</b> (170)	<b>Z 2,7</b> (170)	<b>Z 3,5</b> (170)	<b>Z 4,5</b> (170)	<b>Z 5,2</b> (170)	<b>Z 6,9</b> (140)
HC 32	<b>Z 2,0</b> (170)	<b>Z 2,7</b> (170)	<b>Z 3,5</b> (170)	<b>Z 4,5</b> (140)	<b>Z 5,2</b> (115)	<b>Z 6,9</b> (85)
HC 44	<b>Z 5,2</b> (170)	<b>Z 6,9</b> (170)	<b>Z 8,8</b> (170)	<b>Z 9,8</b> (160)	<b>Z 11,3</b> (140)	
HC 42	<b>Z 5,2</b> (170)	<b>Z 6,9</b> (160)	<b>Z 8,8</b> (120)	<b>Z 9,8</b> (100)	<b>Z 11,3</b> (80)	
HC 48	<b>Z 5,2</b> (180)	<b>Z 6,9</b> (180)	<b>Z 8,8</b> (180)	<b>Z 9,8</b> (160)	<b>Z 11,3</b> (160)	
HC 46	<b>Z 5,2</b> (180)	<b>Z 6,9</b> (180)	<b>Z 8,8</b> (180)	<b>Z 9,8</b> (150)	<b>Z 11,3</b> (120)	
HCW 24	<b>Z 0,5</b> (150)	<b>Z 1,0</b> (150)	<b>Z 1,8</b> (150)			
HCW 22	<b>Z 0,5</b> (150)	<b>Z 1,0</b> (150)	<b>Z 1,8</b> (110)			
HCW 34	<b>Z 2,0</b> (170)	<b>Z 2,7</b> (170)	<b>Z 3,5</b> (170)	<b>Z 4,5</b> (135)	<b>Z 5,2</b> (115)	<b>Z 6,9</b> (85)
HCW 44	<b>Z 5,2</b> (170)	<b>Z 6,9</b> (170)	<b>Z 8,8</b> (130)	<b>Z 9,8</b> (120)	<b>Z 11,3</b> (100)	

<sup>1)</sup> The coding corresponds roughly to the pump delivery with a mains frequency of 50 Hz, but it will be 20% higher with mains 60 Hz.

**Reference current  $I_{ref}$ .**

The reference current  $I_{ref}$  will differ to the nom. current  $I_N$  (see section 1) depending on the capacity of the connected capacitor  $C_B$ .

Type	$I_N$	$C_B$	$I_{ref}$	Type	$I_N$	$C_B$	$I_{ref}$
HCW 14	1.8	(6)	2.1	HCW 22	4.1	(12)	4.4
		8				16	
		12				2.5	
HCW 12	2.2	(6)	2.2	HCW 34	5.5	(25)	6
		12				40	
		16				2.6	
HCW 24	3.0	(12)	3.3	HCW 44	10.1	60	10.1
		16				4.6	
		24					

The voltage applied to the capacitor will be in the following range:

Type	$P_{oper.}/P_{max} = 0$ (no load)	$P_{oper.}/P_{max} = 1$ (max. load)
HCW 14	480 ... 490V	410 ... 420V
HCW 24	480 ... 490V	410 ... 420V
HCW 12	390 ... 400V	330 ... 340V
HCW 22	440 ... 450V	370 ... 380V
HCW 34	425 ... 430V	360 ... 370V
HCW 44	430 ... 440V	360 ... 370V

### 3. Electrical connection

#### 3.1 Circuitry

##### Type HC(W) 1, 2, 3

Version for 3-phase mains

400V  $\Upsilon$  50 Hz  
460V  $\Upsilon$  60 Hz

230V  $\Delta$  50 Hz  
265V  $\Delta$  60 Hz

500V  $\Upsilon$  50 Hz

Version for 1-phase mains <sup>1)</sup>

230V 50 Hz  $\perp$   
110V 60 Hz  $\perp$

Circuitry customer furnished L1, L2, L3 and PE

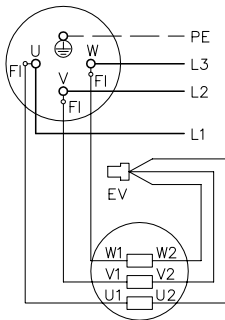

Internal circuitry by HAWE

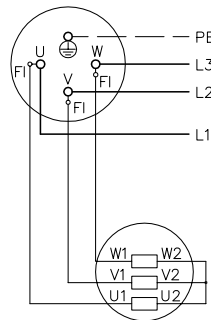
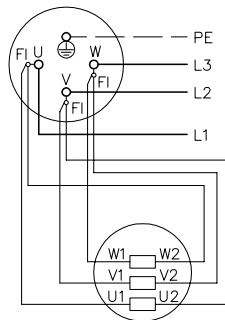

Circuitry customer furnished L1, N, PE and C<sub>B</sub>

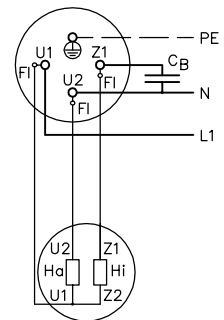

Internal circuitry by HAWE

FI = blade terminal  
EV = insulated crimp connector

##### Type HC(W) 4

Version for 3-phase mains

400V  $\Upsilon$  50 Hz  
460V  $\Upsilon$  60 Hz

230V  $\Delta$  50 Hz  
265V  $\Delta$  60 Hz

Version for 1-phase mains <sup>1)</sup>  
230 V 50 Hz  $\perp$

Circuitry customer furnished L1, L2, L3 and PE

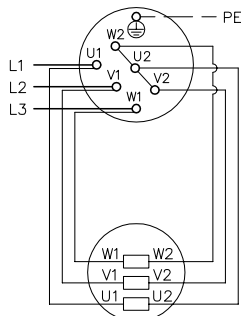

Internal circuitry by HAWE

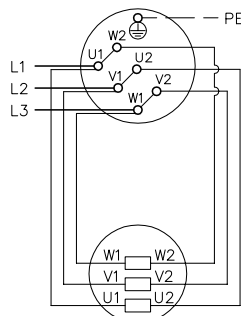

Circuitry customer furnished L1, N, PE and C<sub>B</sub>

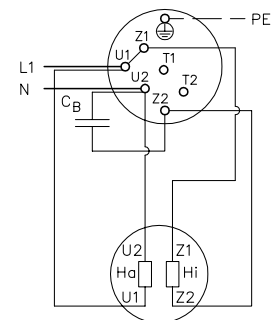

Internal circuitry by HAWE

<sup>1)</sup> The customer has to supply and mount an appropriate operation capacitor at a suitable location. It has to be connected to terminals U2 and Z1, see illustration of the connection pattern. System must be depressurized during start !

### 3.2 Versions for 3-phase mains type HC

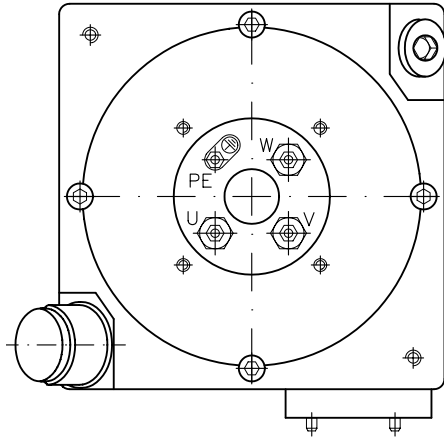
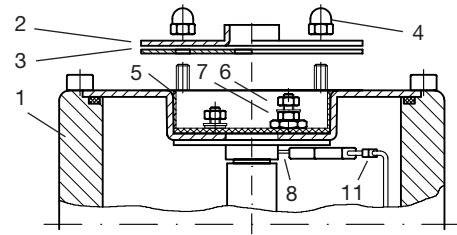

Circuitry by HAWE for 400V  $\Upsilon$

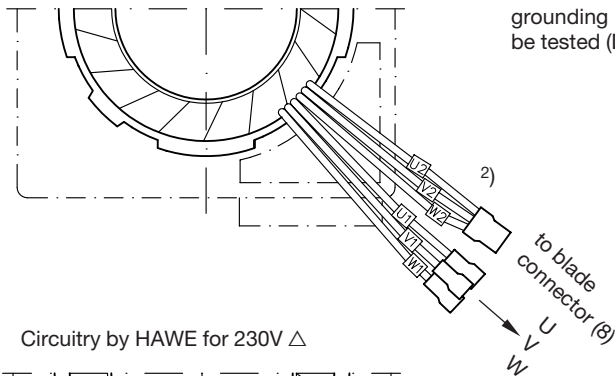

Circuitry by HAWE for 230V  $\Delta$

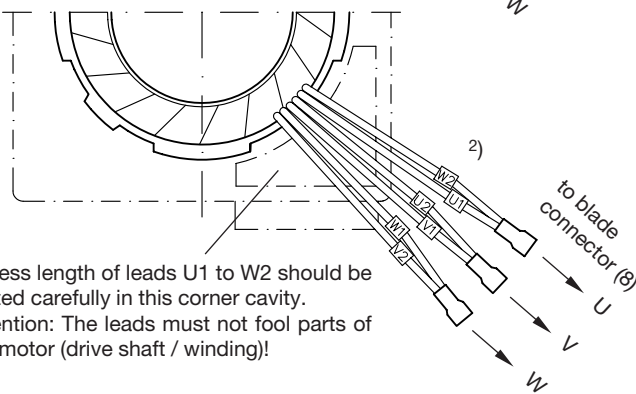

Excess length of leads U1 to W2 should be rooted carefully in this corner cavity.  
Attention: The leads must not fool parts of the motor (drive shaft / winding)!

1) Every motor suited for mains 400/230V 50 Hz may be operated with mains 460/265V 60 Hz as well

2) Leads coding: black (all leads) = with label U1 ... W2)  
or diff. colours = blue (U1); purple (U2)  
brown (V1); red (V2)  
black (W1); orange (W2)

#### Standard 400V $\Upsilon$ and 230V $\Delta$ 50 Hz <sup>1)</sup>

The motor is connected by HAWE for  $\Upsilon$  3~400V or  $\Delta$  3~230V on the under side of the bearing plate. See connection pattern in sect. 3.1. This internal connection by HAWE is according to the voltage specified by the customer (state in uncoded text). A later conversion from  $\Upsilon$  to  $\Delta$  and vice versa by the customer is possible, see below.

#### Converting $\Upsilon$ - circuitry into $\Delta$ or vice versa

A later conversion from  $\Upsilon$  to  $\Delta$  and vice versa by the customer is possible, see below.

New terminal connector 9, 10, and eventually 12 are required (for parts No. see below), when converting the circuitry.

Industrial standard wire leads (3+gnd) should be utilized for mains supply connection. The cross sectional area should be 1.5 mm<sup>2</sup> as minimum.

① Remove parts No. 4, 2 and 3 from the bearing plate

② Connect the individual leads equipped with crimped eyelets to the terminals U, V, W and PE.  
The cable gland is to be furnished by the customer.  
**Attention:** Absolute care has to be taken that the insulation strip 5 remains in its intended location!  
The flawless working of the grounding conductor has to be tested (DIN VDE 0100)!

Converting  $\Upsilon$ - circuitry into  $\Delta$ : <sup>2)</sup>  
Cut leads U1, V1 and W1 directly at the crimp connectors 9 -10 as well as U2-V2-W2 at terminal connector 12.

**Attention:** Do not remove the coding labels 11 (U1 to W2) from the leads!

Remove insulation from the lead terminals and install new crimp connectors 9 -10 acc. to  $\Delta$ -circuitry U1 + W2, V1 + U2 and W1 + V2. Connect lead terminals to blade connector 8 acc. to  $\Delta$ -circuitry. Root the leads in a loop that they are pushed in the cavity if the bearing plate 1 is installed.

Converting  $\Delta$ - circuitry into  $\Upsilon$ : <sup>2)</sup>  
Cut leads U1 + W2, V1 + U2 and W1 + V2 directly at the crimp connectors 9 - 10.

**Attention:** Do not remove the coding labels 11 (U1 to W2) from the leads!

Remove insulation from the lead terminals and install new crimp connectors 9 - 10 acc. to  $\Upsilon$ - circuitry U1, V1 and W1, join leads U2, V2 and W2 with terminal crimp connector 12 to form the star point.

Connect lead terminals U1, V1 and W1 to blade connector 8 acc. to  $\Upsilon$ -circuitry. Root the leads in a loop that they are pushed in the cavity if the bearing plate 1 is installed.

③ Reinstall parts No. 3, 2 and 4 and tighten cable gland.

1 Bearing plate	7900 203/1	
2 Terminal cover	7900 205	
3 Seal	7900 206	
4 Nut	DIN 934-M5-8-A2K	
5 Insulation strip	7900 210	
6 Nut	ISO 4032-M4-8-A2K	
7 Washer	ISO 7089/7090-4,3-140HV-A2K	
8 Blade type crimp connector	6.3x0.8/Ø4.3/45° DIN 46244	} Crimp connector
9 Blade terminal 6.3	order No. 05F522 (Co. Bürklin)	
10 Insulation sleeve for blade type crimp connector	order No. 07F395 (Co. Bürklin)	
11 Leads coding labels U1 to W2		
12 Insulated leads terminal connector RCJ (Schlemmer) for star connection point (crimp type)		
13 Socket head screw DIN 6912 M 6x12-8.8-A2K		

### 3.3 Version for 1-phase mains type HCW

The terminals U1, U2, Z1 and PE are accessible as described under ① to ③ above for the 3-phase mains version. The motor is internally connected by HAWE, like described in sect. 3.1. An alternation is neither required nor possible.

Only with type HCW 4: Terminals T1 and T2 are for the winding protection switch (temperature switch).

Type HCW 1, 2, 3

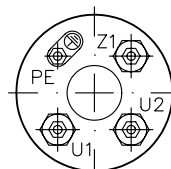

Type HCW 4

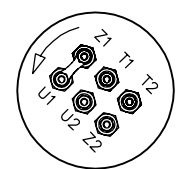

## 4. Operation with 1-phase mains 230 V AC

The compact hydraulic power packs type HC for 3-phase mains 400/230V AC may be connected to 1-phase mains 230V AC when a so-called „Steinmetz Circuitry“ is employed.

The performance will be approx. 30 ... 40% lower when compared with type HCW and the operation capacitor must be bigger (e.g. HC 24 approx. 30 ... 40  $\mu\text{F}$ , HC 34 approx. 60 ... 80  $\mu\text{F}$ ).

Pumps type HC equipped with this special, external circuitry are not suited to replace type HCW, but may be employed if no 3-phase mains is available and type HC must be connected to 1-phase mains as an exception to the rule. This is only possible if the pump features a  $\Delta$ -circuitry for 230V, otherwise the  $\Upsilon$ -circuitry for 400V must be converted (see sect. 3.2).

**Attention:** The pump will not start against pressure! Therefore the connected directional valves must provide a possibility to start the pump against a depressurized system e.g. by means of an idle circulation valve.

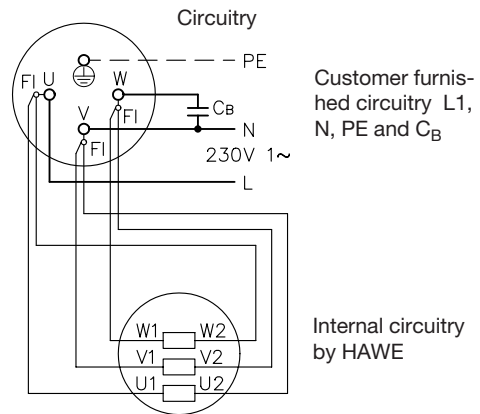

## 5. Motor protection against overheating

The load related current consumption differs in most operation conditions from the nom. current  $I_N$  and is usually higher. Therefore the set current  $I_{set}$  should not be adjusted to  $I_N$ , when utilizing a protective motor switch, but to  $I_M$  which corresponds to the setting of the pressure limiting valve ( $I_{set} \approx 0.7 I_M$ ). This will cover situations where the motor is stalled as well as if there is no disabling signal emitted at the end of an operation cycle (during S2 or S3-operation).

**Attention:** The protective motor switch doesn't offer any absolute protection against overheating, especially, if the immediate ambient temperature is higher than approx. 40°C. Therefore the running and stand-still periods should be monitored at least by an idiot light to make it recognizable for the operator. It is recommended to employ an electrical supervision circuit, if a system is not permanently checked by an operator, which emits a signal and will automatically cut-off the system either immediately or after an sufficient period in case of a malfunction (motor is energized even during an intended stand-still period).

The guideline figures for the adjusted current  $I_{set}$  do only apply if the winding is completely fluid immersed. This is the case only if no more than 0.05 l (HC 1..), 0.25 l (HC 2..), 1 l (HC 3..), and 2 l (HC 4..) are removed from the pump. Otherwise, if more fluid is removed per operation cycles, with the winding being no longer fluid immersed, the response time for the protective switch will be too long due to a lack of fluid cooling. Therefore an supervision circuit (see above) is highly recommended if more fluid is removed.

## 6. Run-down

A certain pressure rise will occur due to pump motor run-down, if the pump is directly connected to a hydraulic cylinder via a pipe, such as e.g. in the typical connection pattern for clamping equipment (connection block B..) and if the power unit is switched off by a pressure switch as soon as a pre-selected pressure is achieved. The extend of this additional pressure rise depends on the pre-selected pressure, the volume of the connected consumers and the pump delivery rate. If such pressure rises are undesired, it will be necessary to reset the pressure limiting valve to match the shut-off point of the pressure switch. The result will be that all excess delivery of the pump during run-down will be conducted to the tank via the pressure limiting valve.

Procedure for matching is as follows:

- ① Fully open the pressure limiting valve.
- ② Adjusting the pressure switch on highest value (turning the adjustment screw clockwise up to the stop).
- ③ Start the pump (pressure gauge and all consumers connected) and turn up the pressure limiting valve until the pressure gauge shows the desired final operation pressure.
- ④ Turn back the pressure switch until the pump is switched off at the preset pressure (see ③).
- ⑤ Lock pressure switch and pressure limiting valve in position.

The effect of excessive run-down pressure may also be minimized by utilizing an accumulator or providing additional volume in the consumer line. If the pump is running under full load, i.e. the preset pressure is close to the maximum permissible pressure as listed in D 7900, then effectively no run-down will occur, as the pump will stop almost immediately after shut-off.



## 7. Notes for general lay-out and initial operation

### 7.1 Filling up with fluid

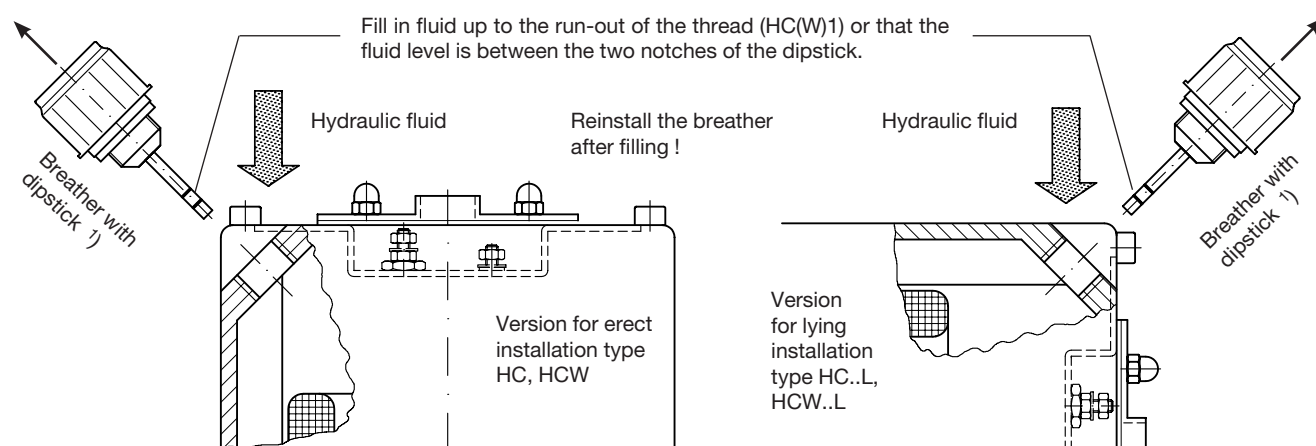

1) Breather without dipstick with type HC(W)1

#### Filling volume in liter

Version	Type	Filling volume	Max. consumable volume
Erect	HC(W) 1..	1.16	0.5
	HC(W) 2..	2.5	1.5
	HC(W) 3..	5.0	3.5
	HC(W) 4..	12	8

Version	Type	Filling volume	Max. consumable volume
Lying	HC(W) 1..L	0.95	0.5
	HC(W) 2..L	2.31	1.1
	HC(W) 3..L	4.95	3.8
	HC(W) 4..L	11	7.8

Hydraulic oil conforming DIN 51514 part 1 to 2;

ISO VG 10 to 68 conform. DIN 51519 or synthetic ester (HEES) conform. VDMA 24568 and 24569.

Only proprietary fluids should be used, pamphlet D 5488 lists approved fluids.

Viscosity for opt. service: approx. 10 ... 500 mm<sup>2</sup>/s during start min. approx. 4; max. approx. 1500 mm<sup>2</sup>/s

Hydraulic oil ISO VG 22, 32 and 46 cover the widest temperature range within the operation viscosity range.

**Attention:** The hydraulic power packs type HC are not suited for use with fire inhibiting fluids type HFA(B), HFC, HFD.. conforming VDMA 24317 and biologically degradable pressure fluids based on polyglycole (HEPG).

Electrically hazardous: Any fluid types containing water must not be used (danger of short circuit).

Any fluids based on seed oil are not suited as the permanent contact with the hot motor winding (fluid immersed motor) would cause rapid aging of them.

### 7.2 Direction of rotation

Radial piston pump arbitrary

Gear pump, dual circuit pump counter clockwise

(The rotation direction can be only detected by checking the delivery flow. The connection of two of the three mains wires have to be interchanged at the terminal strip, when there is no delivery with 3-phase pumps)

### 7.3 Initial operation and bleeding

The pump cylinders will be bled automatically if the pump runs or is switched on/off several times and the directional valves are switched into idle circulation. Another way is to install a pipe fitting with a short piece of pipe and prolonged by a translucent tube. The other end of the tube should be put into the filler neck, held firmly and sealed with a non-fluffing cloth. Now switch on the pump and let it run until no more bubbles are visible.

Next after the pump cylinders are bled any air dragged into the system should be removed by opening the bleeder screws at the consumers (if provided) until no more bubbles are detected or by operating all functions of the circuitry without load until all cylinders, motors, etc. move steadily and without any hesitation.

### 7.4 Servicing

The hydraulic power packs type MP and directly mounted valves are almost maintenance free. Only the fluid level and the insulation resistance of the motor winding should be checked regularly depending on operation conditions. The fluid should be exchanged every year as a general rule, but more frequently if tests show aging or contamination.

### 7.5 Spare parts

Repairs (replacing service items) are possible by competent craftsmen. The motor can't be repaired or replaced by the customer. Therefore if the motor is defect, the complete pump should be returned to our facilities for an overhaul. There are spare parts lists available (E 7900..), pls. state your pump type acc. to the type plate.

München, 01.08.2012

**Declaration of Incorporation within the meaning of the  
Machinery Directive 2006/42/ EC,  
appendix II, No.1 B****Compact hydraulic power pack type HC and HCW  
acc. to our pamphlet D 7900  
(latest release)**

is an incomplete machine (acc. to article 2g), which is exclusively intended for installation or assembly of another machinery or equipment.

The specific technical documents, necessary acc. to appendix VII B, were prepared and are transmitted in electronic form to the responsible national authority on request.

Risk assesment and analysis are implemented according to appendix I of the Machinery Directive.

The dept. MARKETING is authorized to compile the specific technical documents necessary acc. to appendix VII B

HAWE Hydraulik SE  
Dept. MARKETING  
Streitfeldstraße 25  
D-81673 München

The following basic safety and health protection requests acc. to appendix 1 of below guideline do apply and are complied with:

*DIN EN ISO 4413:2010*

*"Hydraulic fluid power – General rules and safety requirements for systems and their components"*

We assume that the delivered equipment is intended for the installation into a machine.

Putting in operation is forbidden until it has been verified that the machine, where our products shall be installed, is complying with the Machinery Directive 2006/42/ EC.

This Declaration of Incorporation is void, when our product has been modified without our written approval.

HAWE Hydraulik SE

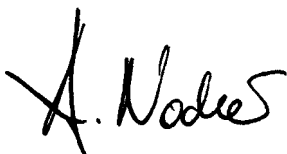

i.A. Dipl.-Ing. A. Nocker (Produktmanagement)