

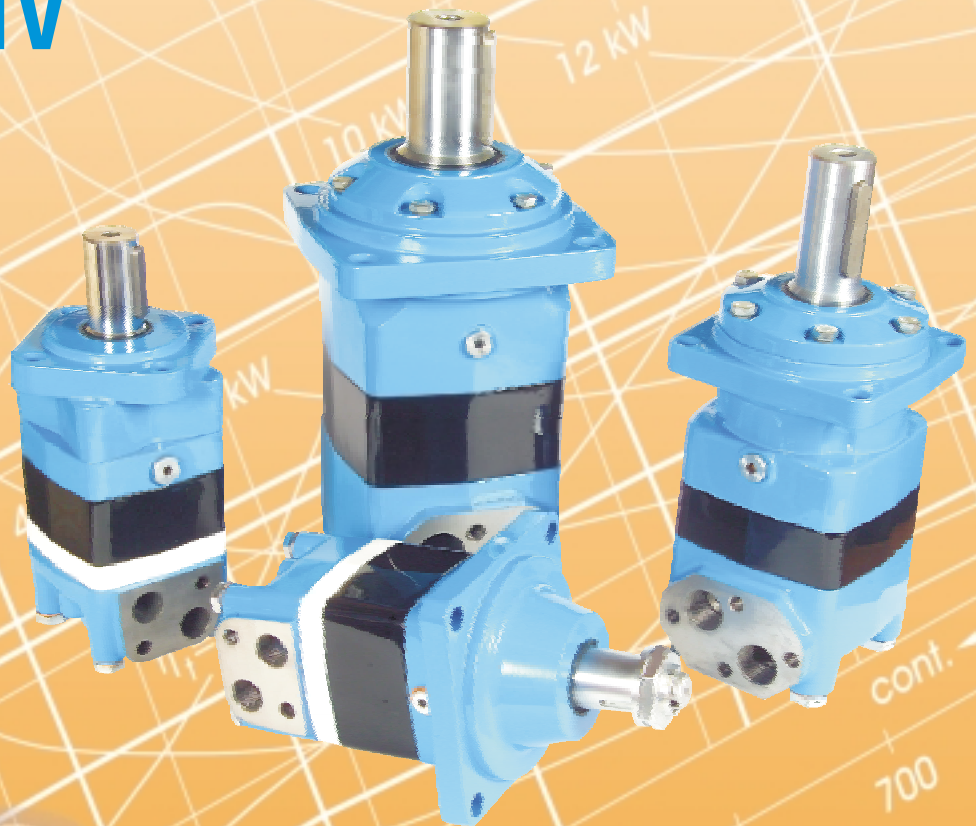

DISC VALVE HYDRAULIC MOTORS

TYPE MS
MSY
MT
MTM
MV



DISC VALVE HYDRAULIC MOTORS

CONTENTS

	Page
● Hydraulic Motors Series MS	4
● Hydraulic Motors Series MSY.....	24
● Hydraulic Motors Series MT	31
● Hydraulic Motors Series MTM	43
● Hydraulic Motors Series MV	55
● Motor Special Features.....	65
● Motors with Speed Sensor.....	66
● Motor Application	68

DISC VALVE HYDRAULIC MOTORS

GENERAL INFORMATION:

Orbit motors convert hydraulic energy (pressure, oil flow) into mechanical energy (torque, speed). Hydraulic orbit motors operate on the principle of an internal gear (rotor) rotating within a fixed external gear (stator). The internal gear transmits the torque generated by the application of pressure from hydraulic oil fed into motor which is then delivered via the motor's output shaft. Orbit motors have high starting torque and constant output torque at wide speed range. The output shaft runs on tapered roller bearings and can absorb high axial and radial forces.

DISTRIBUTOR VALVE

MS, MT, MTM, MV series motors have disk valve: the distributor valve has been separated from output shaft and is driven by short cardan shaft. A balance plate counterbalances the hydraulic forces around the distributor valve. It gives the motors high efficiency- even at high pressures, and good starting characteristics.

GEARWHEEL SET

There are two forms of gearwheel set: Gerotor set have plain teeth and Roll-gerotor set with teeth fitted with rollers.

MS, MT, MTM, MV series motors have roll-gerotor set. The rollers reduce local stress and the tangential reaction forces on the rotor reducing friction to a minimum. This gives long operating life and better efficiency even at continuous high pressures.

FEATURES:

Standard Motor

The standard motor mounting flange is located as close to the output shaft as possible. This type of mounting supports the motor close to the shaft load. This mounting flange is also compatible with many standard gear boxes.

Wheel Motor

The wheel motor mounting flange is located near the center of the motor which permits part or all of the motor to be located inside the wheel or roller hub. In traction drive applications, loads can be positioned over the motor bearings for best bearing life. This wheel motor mounting flange provides design flexibility in many applications.

Short Motor

This motor is assembled without the output shaft, bearings and bearing housing and has the same drive components as the standard motors. The short motor is especially suited for applications such as gear boxes, winch, reel and roll drives. Short motor applications must be designed with a bearing supported internal spline to mate with the short motor drive. Product designs using these hydraulic motors provide considerable cost savings.

Low Leakage

LL Series hydraulic motors are designed to operate at the whole standard range of working conditions (pressure drop and frequency of rotation), but with considerable decreased volumetric losses in the drain ports. This motors are suitable for hydraulic systems with series-connected motors with demands for low leakage.

Low Speed Valve

LSV feature optimizes the motor for low-speed performance. Motors with this valving provide very low speed while maintaining high torque. They are designed to run continuously at low speed (up to 200 min⁻¹) at normal pressure drop and reduced flow. Optimal run is guaranteed at frequency of rotation from 20 to 50 min⁻¹. Motors with this valving have an increased starting pressure and are not recommended for using at pressure drop less than 40 bar.

High Pressure Shaft Seal

The high pressure shaft seals allow the motors to withstand high case pressures at high speeds without external drain line.

Motors with Speed Sensor

Motors are available with integrated inductive sensor who registered the speed of the motor. The sensor is a Hall effect device and produced electric output signal with a standard voltage that can be used for regulating the speed of a motor. The torque and radial load of the motor are not affected by the installation of speed sensor.

HYDRAULIC MOTORS MS



APPLICATION

- » Conveyors
- » Metal working machine
- » Machines for agriculture
- » Road building machines
- » Mining machinery
- » Food industries
- » Special vehicles etc.

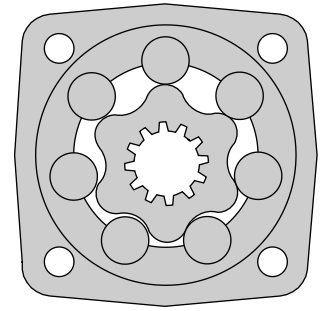

CONTENTS

Specification data	5 ÷ 6
Function diagrams	7 ÷ 12
Dimensions and mounting	13 ÷ 14
Wheel motor	15
Motor with Drum brake- MSB	16
Shaft extensions	17
Permissible shaft loads	18
Function diagram for MSB	18
Permissible Shaft Seal pressure.....	19
Tacho connection	19
Dimensions and mounting- MSS, V, U	20 ÷ 22
Internal Spline data	22
Order code	23

OPTIONS

- » Model- Disc valve, roll-gerotor
- » Flange and wheel mount
- » Short motor
- » Motor with Drum Brake
- » Tacho connection
- » Speed sensing
- » Side and rear ports
- » Shafts- straight, splined and tapered
- » Metric and BSPP ports
- » Other special features

GENERAL

Displacement, [cm ³ /rev.]	80,5 ÷ 564,9
Max. Speed, [RPM]	130 ÷ 810
Max. Torque, [daNm]	20 ÷ 58
Max. Output, [kW]	20 ÷ 6,9
Max. Pressure Drop, [bar]	100 ÷ 200
Max. Oil Flow, [l/min]	75
Min. Speed, [RPM]	5 ÷ 10
Permissible Shaft Loads, [daN]	P _a = 500
Pressure fluid	Mineral based- HLP(DIN 51524) or HM(ISO 6743/4)
Temperature range, [°C]	-30 ÷ 90
Optimal Viscosity range, [mm ² /s]	20 ÷ 75
Filtration	ISO code 20/16 (Min. recommended fluid filtration of 25 micron)

Oil flow in drain line

Pressure drop (bar)	Viscosity (mm ² /s)	Oil flow in drain line (l/min)
140	20	1,5
	35	1
210	20	3
	35	2

Pressure Losses

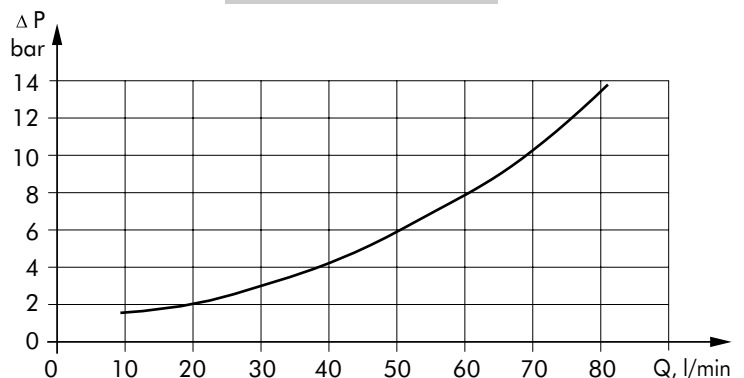

SPECIFICATION DATA

Type	MS 80	MS 100	MS 125	MS 160	MS 200	
Displacement [cm ³ /rev.]	80,5	100	125,7	159,7	200	
Max. Speed, [RPM]	cont.	810	750	600	470	375
	Int.*	1000	900	720	560	450
Max. Torque [daNm]	cont.	20	29,2	37,4	46	46
	Int.*	24	32	41	51,5	60
	peak**	26	32	41	51,5	65
Max. Output [kW]	cont.	16,4	19,5	20	15,5	14
	int.*	22	26	24	21,9	21
Max. Pressure Drop [bar]	cont.	175	205	205	205	160
	Int.*	210	225	225	225	210
	peak**	225	225	225	225	225
Max. Oil Flow [l/min]	cont.	65	75	75	75	75
	Int.*	80	90	90	90	90
Max. Inlet Pressure [bar]	cont.	210	210	210	210	210
	Int.*	250	250	250	250	250
	peak**	300	300	300	300	300
Max. Return Pressure with Drain Line [bar]	cont.	140	140	140	140	140
	Int.*	175	175	175	175	175
	peak**	210	210	210	210	210
Max. Starting Pressure with Unloaded Shaft, [bar]	12	10	10	8	8	
Min. Starting Torque [daNm]	at max. press. drop cont.	16,5	23,9	26	36,9	37,5
	at max. press. drop Int.*	19,4	26,4	31	40,5	48,5
Min. Speed***, [RPM]	10	10	8	8	6	
Weight, [kg] For Rear Ports +0,4 kg	MS(F)	9,9	10,1	10,4	10,8	11,2
	MSW	10,4	10,6	10,9	11,3	11,7
	MSS	7,9	8,1	8,4	8,8	9,2
	MSV	5,8	6	6,3	6,7	7,1
	MSQ	10,3	10,5	10,8	11,2	11,6
	MSB	16,9	17,1	17,4	17,8	18,2

* Intermittent operation: the permissible values may occur for max. 10% of every minute.

** Peak load: the permissible values may occur for max. 1% of every minute.

*** For speeds of 5 RPM lower than given, consult factory or your regional manager.

- 1) Intermittent speed and intermittent pressure must not occur simultaneously.
- 2) Recommended filtration is per ISO cleanliness code 20/16. A nominal filtration of 25 micron or better.
- 3) Recommend using a premium quality, anti-wear type mineral based hydraulic oil HLP(DIN51524) or HM (ISO 6743/4).
If using synthetic fluids consult the factory for alternative seal materials.
- 4) Recommended minimum oil viscosity 13 mm²/s at operating temperatures.
- 5) Recommended maximum system operating temperature is 82°C.
- 6) To assure optimum motor life fill with fluid prior to loading and run at moderate load and speed for 10-15 minutes.

SPECIFICATION DATA (continued)

Type	MS 250	MS 315	MS 400	MS 475	MS 525	MS 565	
Displacement [cm ³ /rev.]	250	314,9	397	474,6	522,7	564,9	
Max. Speed, [RPM]	cont.	300	240	190	160	145	130
	Int.*	360	290	230	190	175	160
Max. Torque [daNm]	cont.	50	54	58	58	58	58
	Int.*	63	63	69	68	69	69
	peak**	72	84	85	84	85	85
Max. Output [kW]	cont.	13,5	11,5	10	8,4	7,6	6,9
	int.*	21	13,5	13	11,3	10,4	9,6
Max. Pressure Drop [bar]	cont.	140	120	100	85	80	75
	Int.*	175	140	120	100	90	85
	peak**	200	185	140	115	105	100
Max. Oil Flow [l/min]	cont.	75	75	75	75	75	75
	Int.*	90	90	90	90	90	90
Max. Inlet Pressure [bar]	cont.	210	210	210	210	210	210
	Int.*	250	250	250	250	250	250
	peak**	300	300	300	300	300	300
Max. Return Pressure with Drain Line [bar]	cont.	140	140	140	140	140	140
	Int.*	175	175	175	175	175	175
	peak**	210	210	210	210	210	210
Max. Starting Pressure with Unloaded Shaft, [bar]	8	8	8	8	8	8	
Min. Starting Torque [daNm]	at max. press. drop cont.	40	51	54	47	47	47
	at max. press. drop Int.*	50	65	63	55	55	55
Min. Speed***, [RPM]	6	5	5	5	5	5	
Weight, [kg] For Rear Ports + 0,4 kg	MS(F)	11,7	12,4	13,3	14,4	14,6	15
	MSW	12,2	12,9	13,8	14,6	15,1	15,5
	MSS	9,7	10,4	11,3	12,1	12,6	13
	MSV	7,6	8,3	9,2	10	10,5	10,9
	MSQ	12,1	12,8	13,7	14,5	15,0	15,4
	MSB	18,7	19,4	20,3	21,1	21,6	23

* Intermittent operation: the permissible values may occur for max. 10% of every minute.

** Peak load: the permissible values may occur for max. 1% of every minute.

*** For speeds of 5 RPM lower than given, consult factory or your regional manager.

- 1) Intermittent speed and intermittent pressure must not occur simultaneously.
- 2) Recommended filtration is per ISO cleanliness code 20/16. A nominal filtration of 25 micron or better.
- 3) Recommend using a premium quality, anti-wear type mineral based hydraulic oil HLP(DIN51524) or HM (ISO 6743/4).
If using synthetic fluids consult the factory for alternative seal materials.
- 4) Recommended minimum oil viscosity 13 mm²/s at operating temperatures.
- 5) Recommended maximum system operating temperature is 82°C.
- 6) To assure optimum motor life fill with fluid prior to loading and run at moderate load and speed for 10-15 minutes.

FUNCTION DIAGRAMS

MS 80

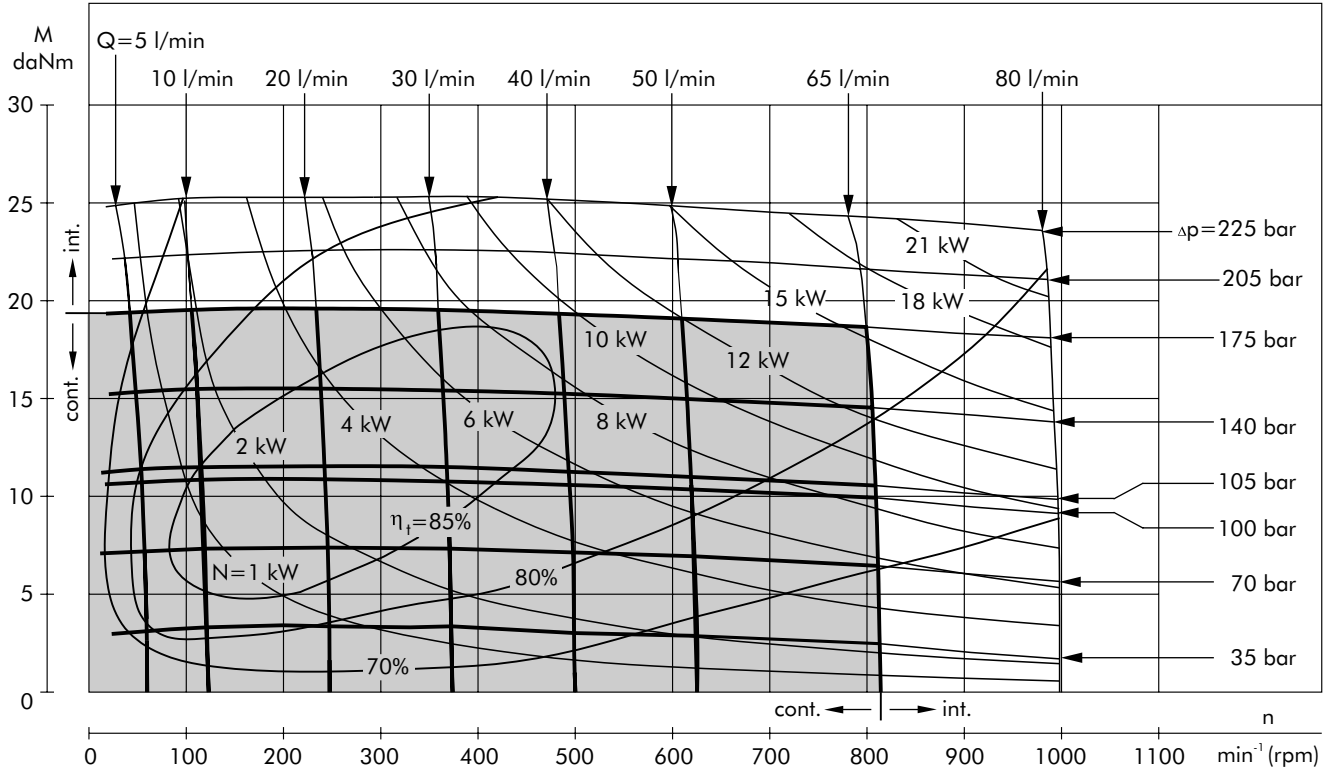

MS 100

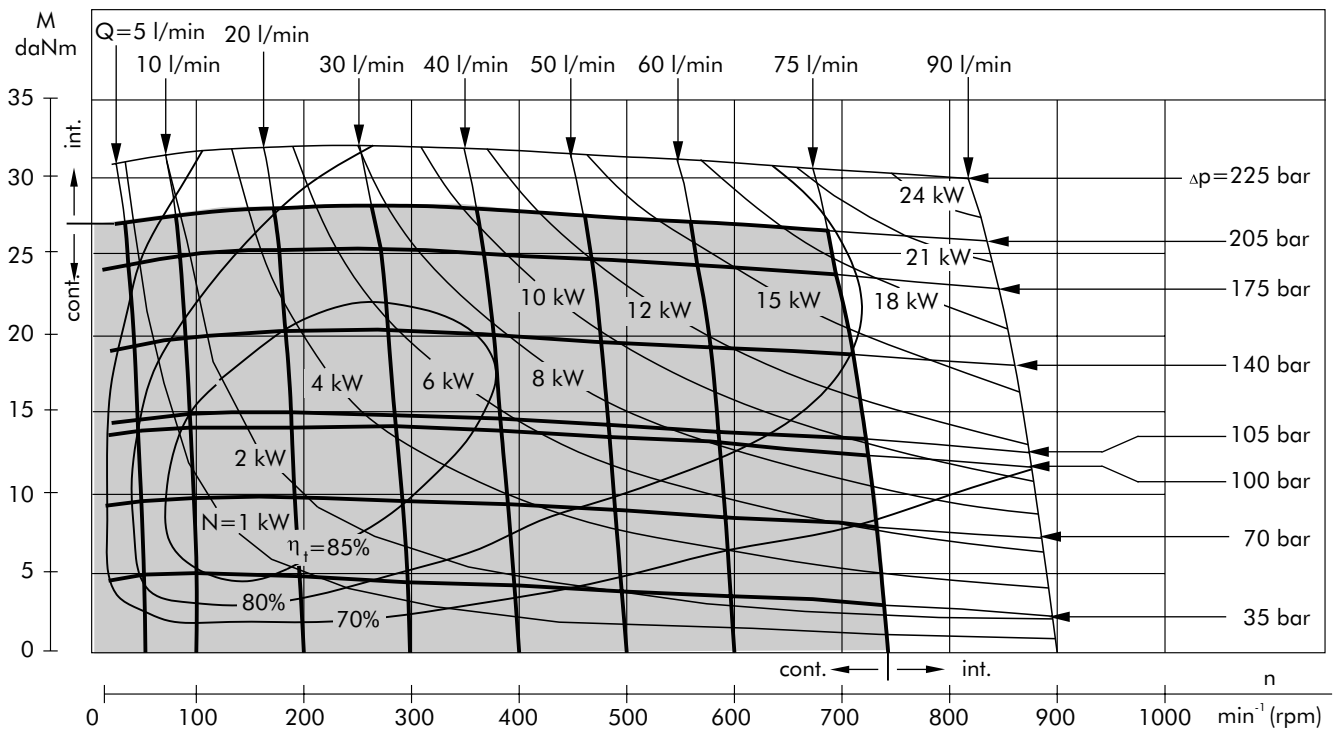

The function diagrams data was collected at back pressure 5 ÷ 10 bar and oil with viscosity of 32 mm²/s at 50 °C.

FUNCTION DIAGRAMS

MS 125

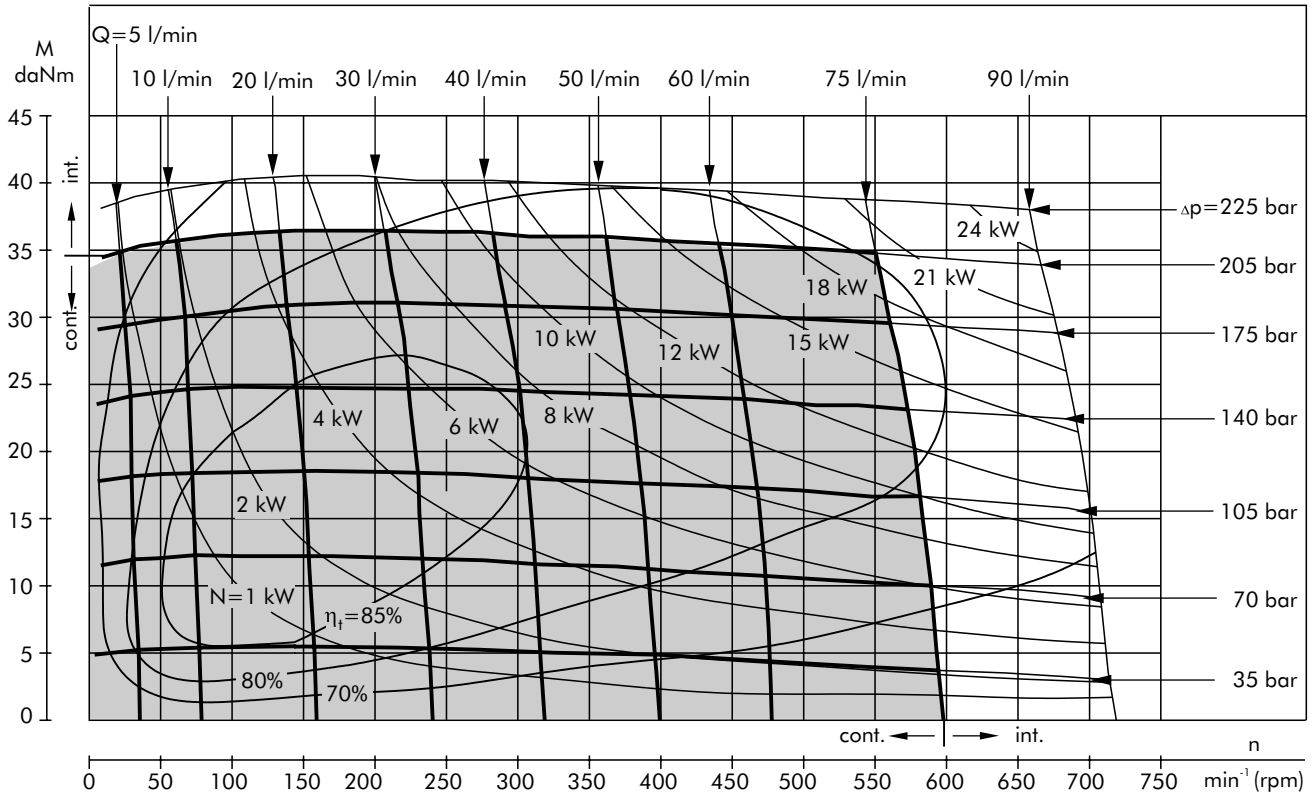

MS 160

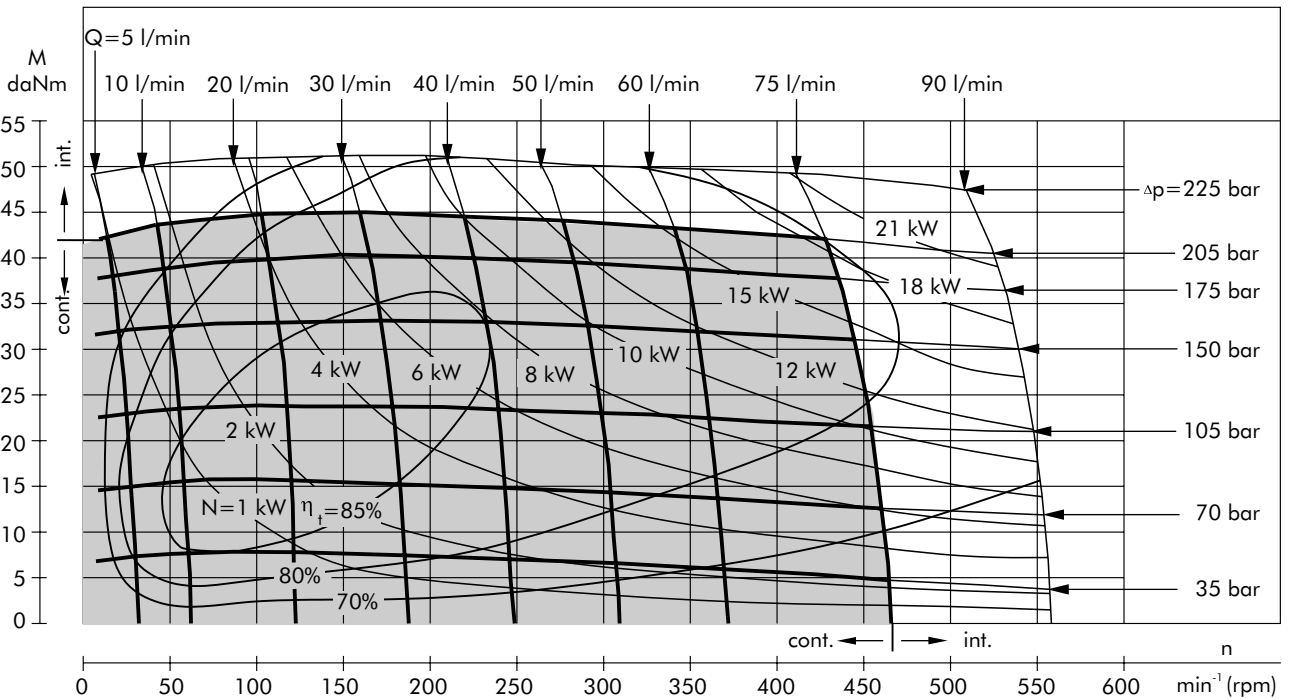

The function diagrams data was collected at back pressure $5 \div 10$ bar and oil with viscosity of $32 \text{ mm}^2/\text{s}$ at 50°C .

FUNCTION DIAGRAMS

MS 200

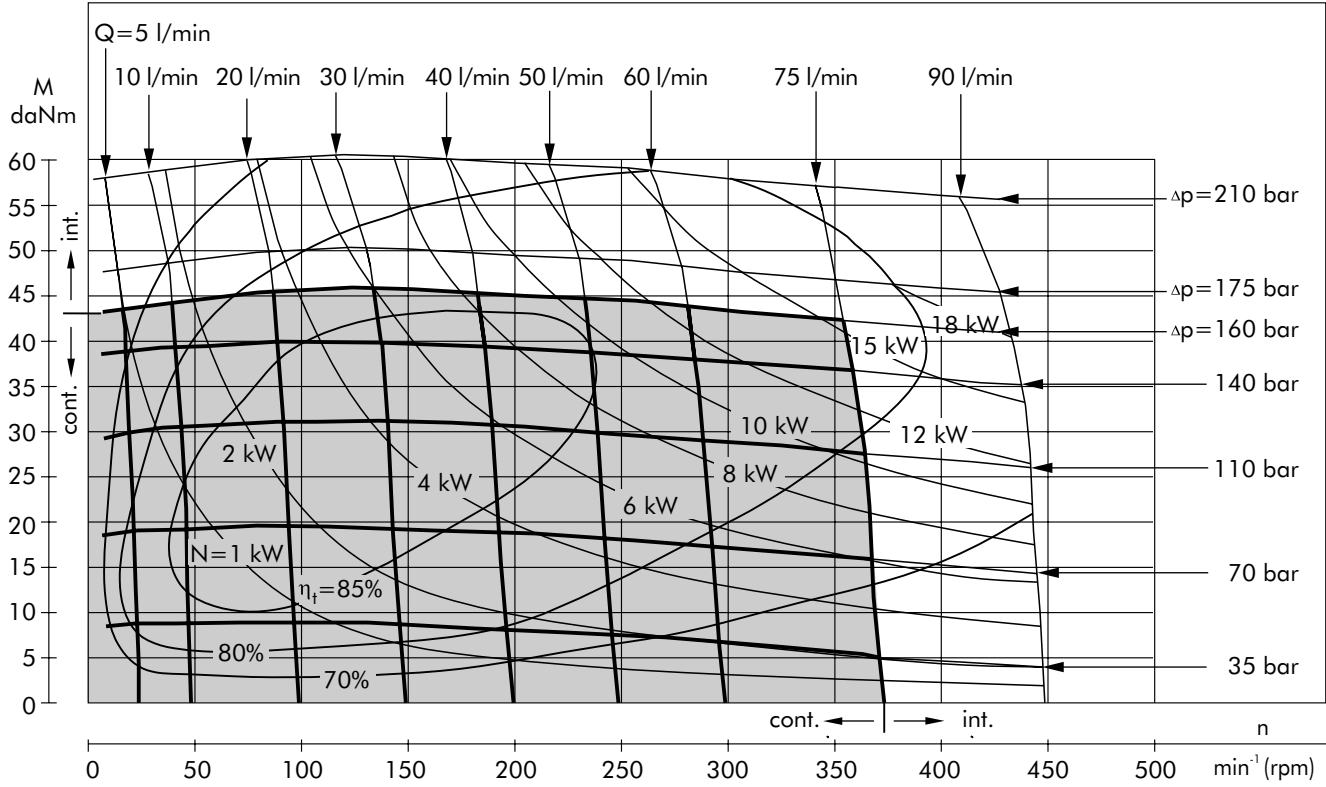

MS 250

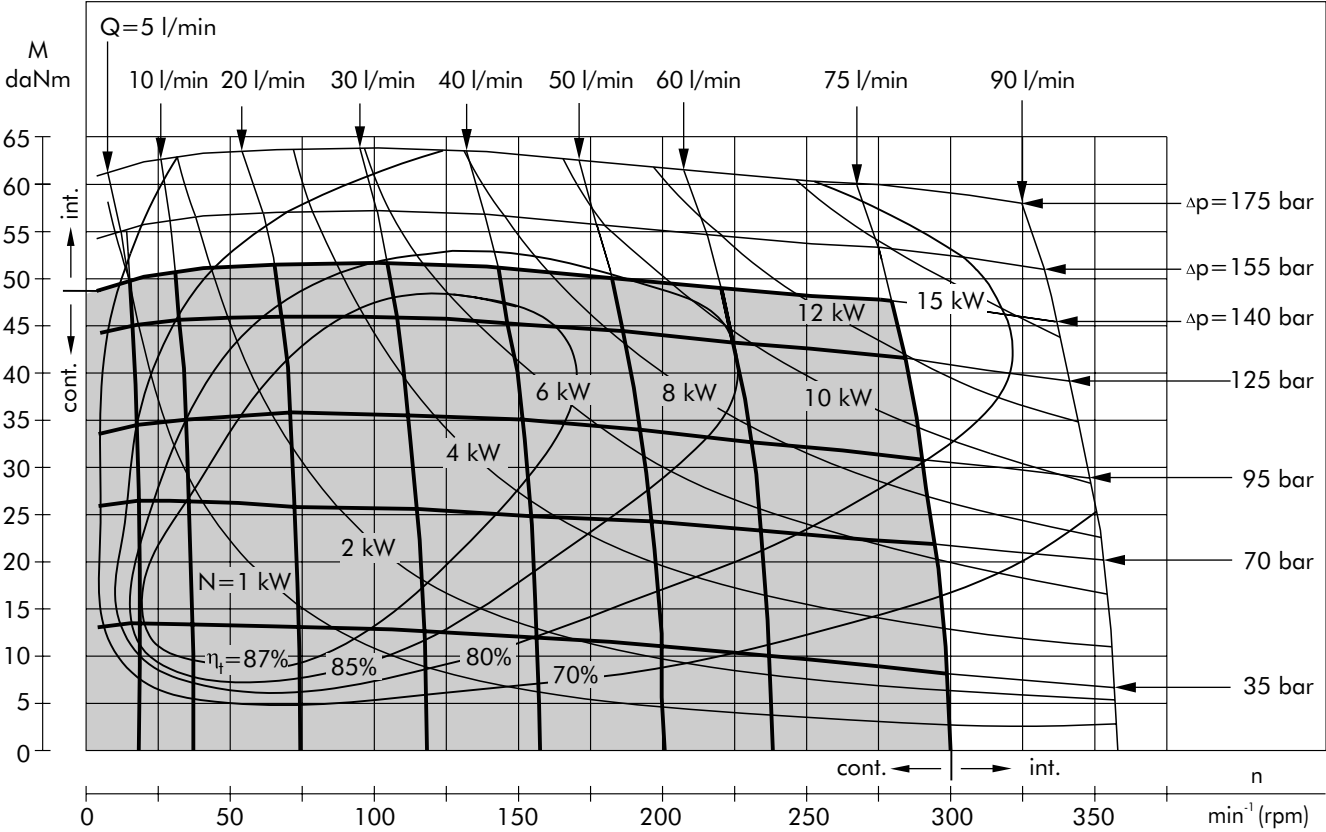

The function diagrams data was collected at back pressure 5 ÷ 10 bar and oil with viscosity of 32 mm²/s at 50° C.

MS 315

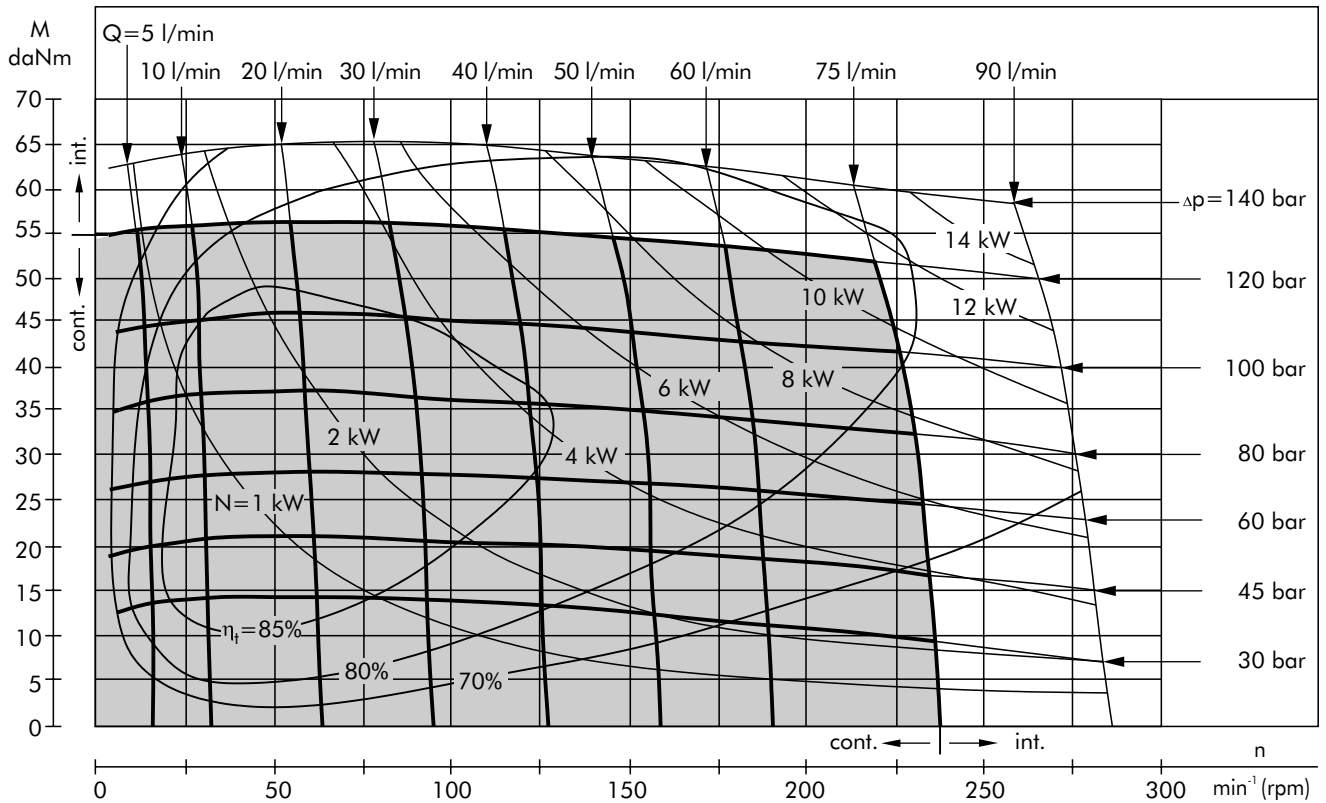

MS 400

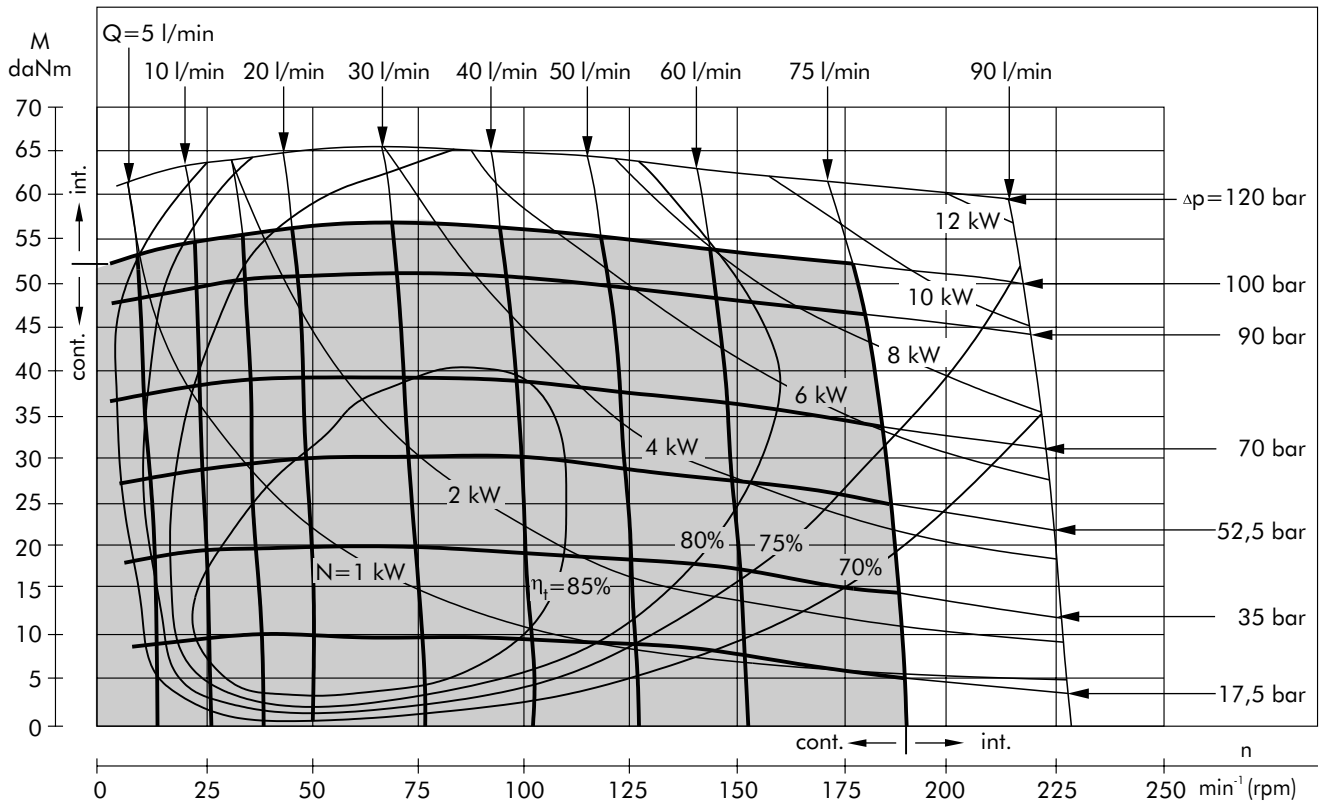

The function diagrams data was collected at back pressure 5 ÷ 10 bar and oil with viscosity of 32 mm²/s at 50° C.

MS 475

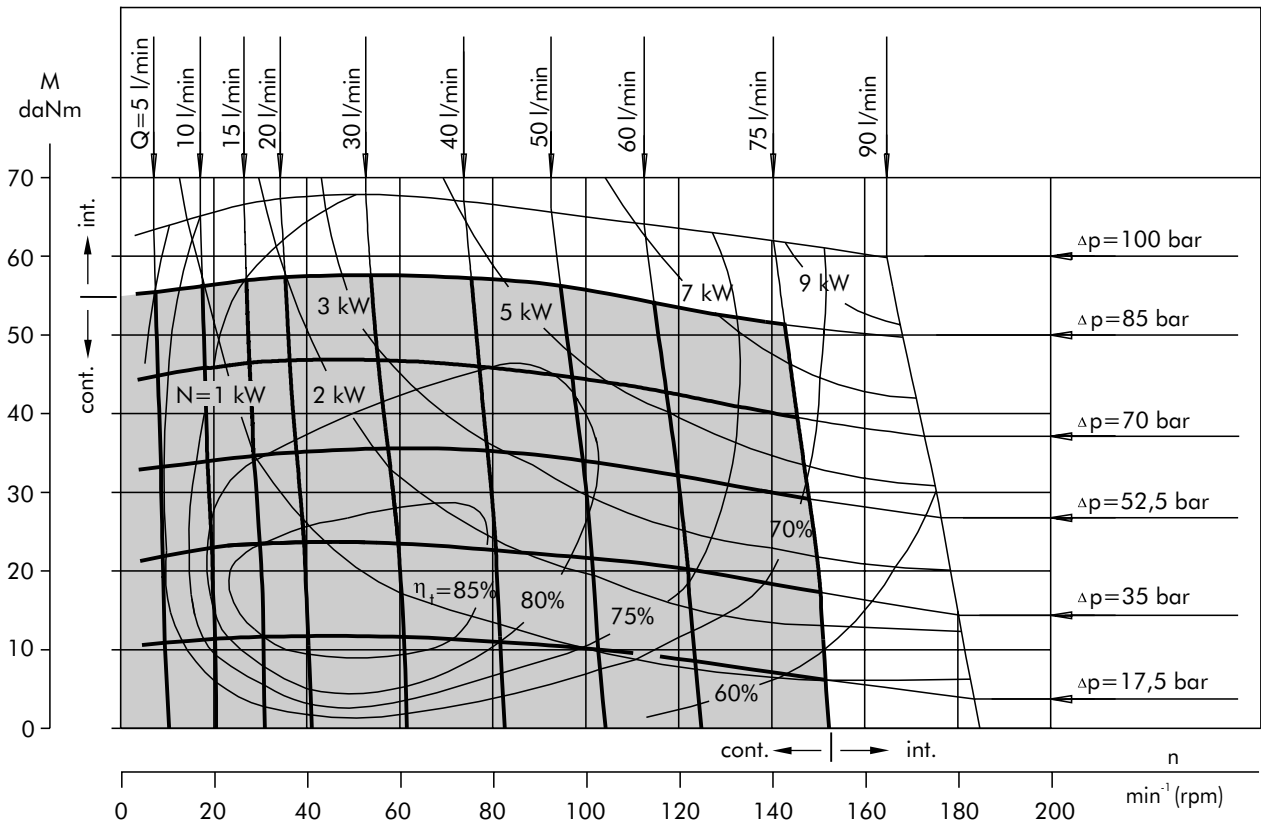

MS 525

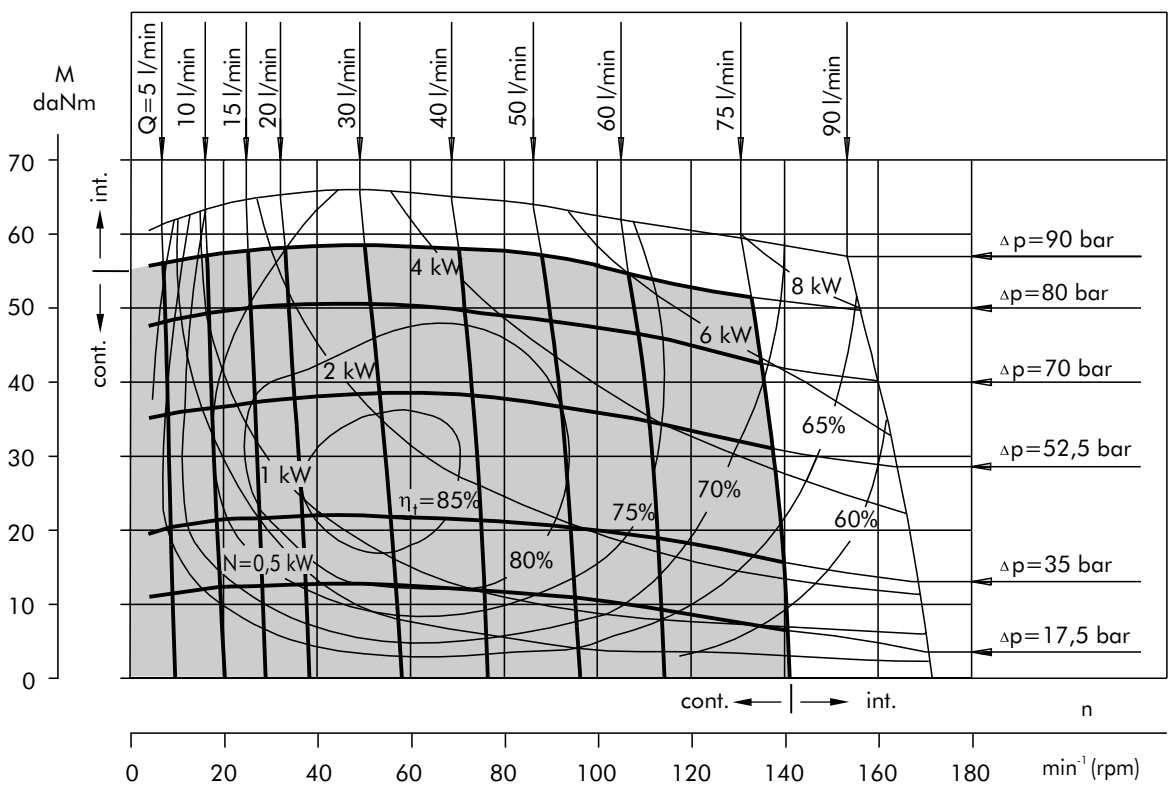

The function diagrams data was collected at back pressure 5 ÷ 10 bar and oil with viscosity of 32 mm²/s at 50° C.

FUNCTION DIAGRAMS

MS 565

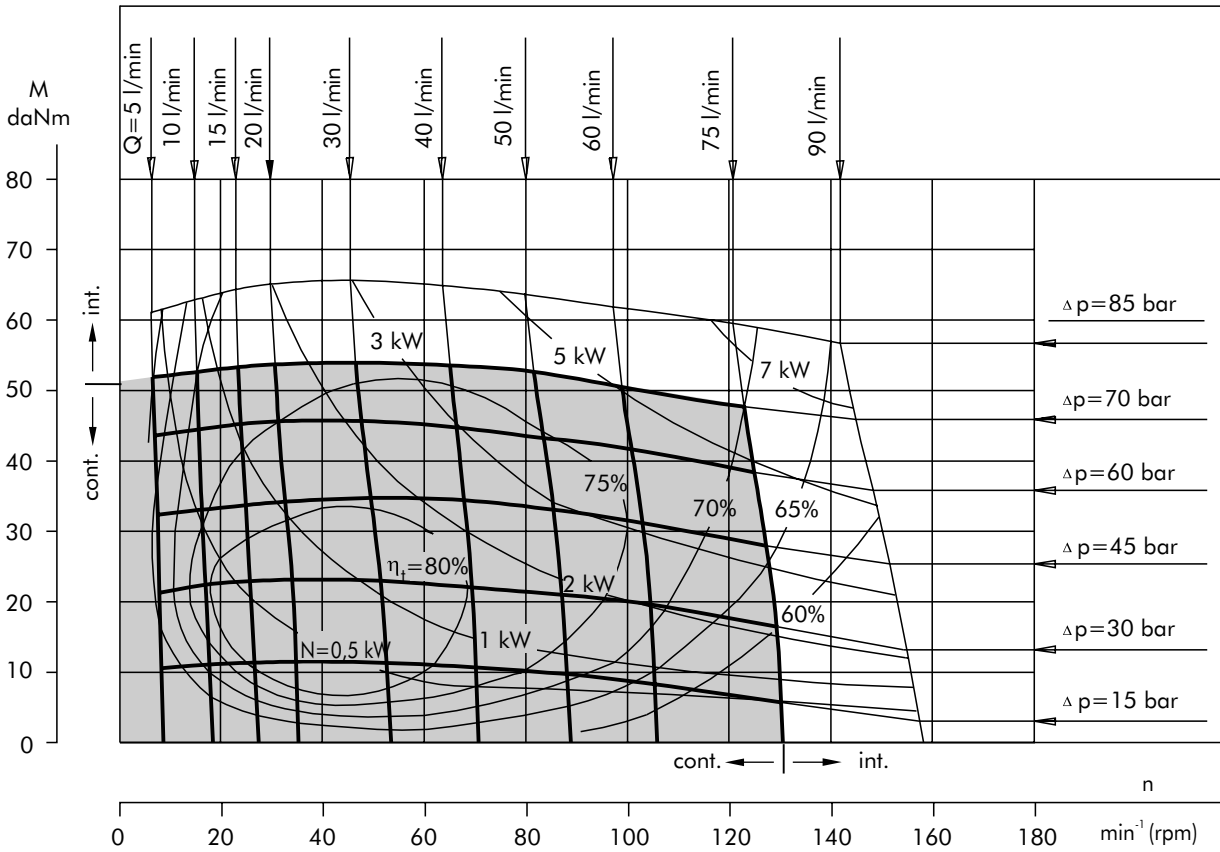

The function diagrams data was collected at back pressure 5 ÷ 10 bar and oil with viscosity of 32 mm²/s at 50° C.

DIMENSIONS AND MOUNTING DATA

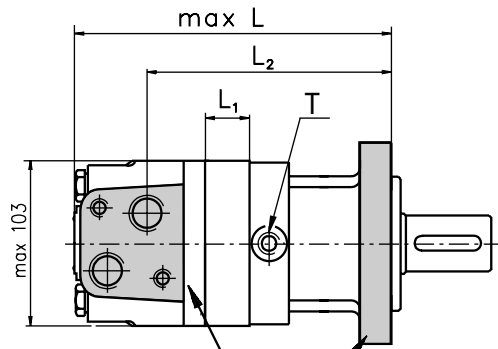

Porting

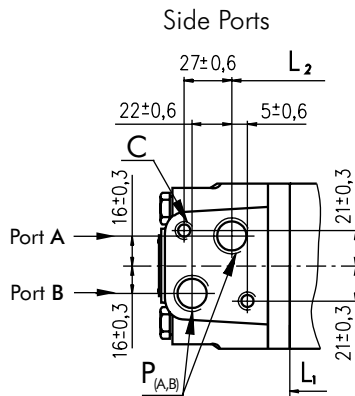

Mounting

SAE A-4 Mount (4 Holes)

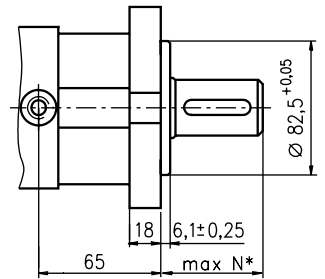
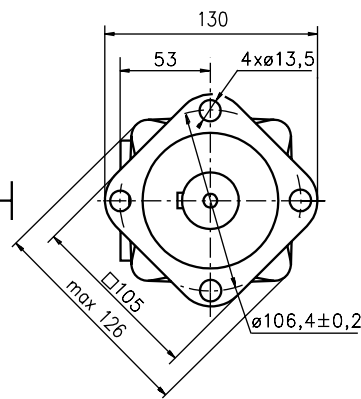

E Rear Ports

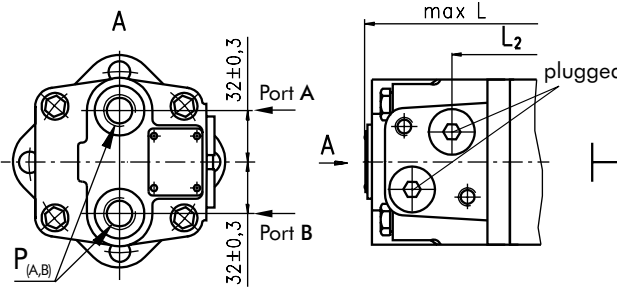

A SAE A-2 Mount (2 Holes)

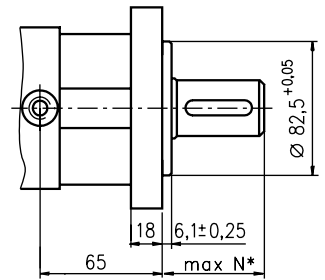
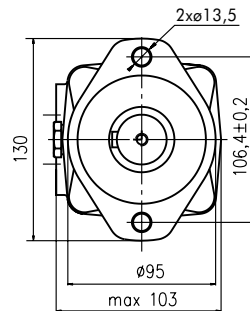

*For N see page 17

- C:** 2xM10-12 mm depth
- P_(A,B):** 2xG1/2 or 2xM22x1,5-15 mm depth
- T:** G 1/4 or M14x1,5- 12 mm depth (plugged)

Standard Rotation
Viewed from Shaft End
Port A Pressurized - CW
Port B Pressurized - CCW

Reverse Rotation
Viewed from Shaft End
Port A Pressurized - CCW
Port B Pressurized - CW

Type	L, mm	L ₂ , mm	Type	L, mm	L ₁ , mm
MS(A) 80	168	124	MS(A)E 80	173	14
MS(A) 100	171	129	MS(A)E 100	177	17,4
MS(A) 125	176	132	MS(A)E 125	181	21,8
MS(A) 160	182	138	MS(A)E 160	187	27,8
MS(A) 200	189	145	MS(A)E 200	194	34,8
MS(A) 250	197	154	MS(A)E 250	203	43,5
MS(A) 315	209	165	MS(A)E 315	214	54,8
MS(A) 400	223	179	MS(A)E 400	228	69,4
MS(A) 475	237	193	MS(A)E 475	242	82,6
MS(A) 525	229	185	MS(A)E 525	234	74,5
MS(A) 565	235	191	MS(A)E 565	240	80,2

DIMENSIONS AND MOUNTING DATA

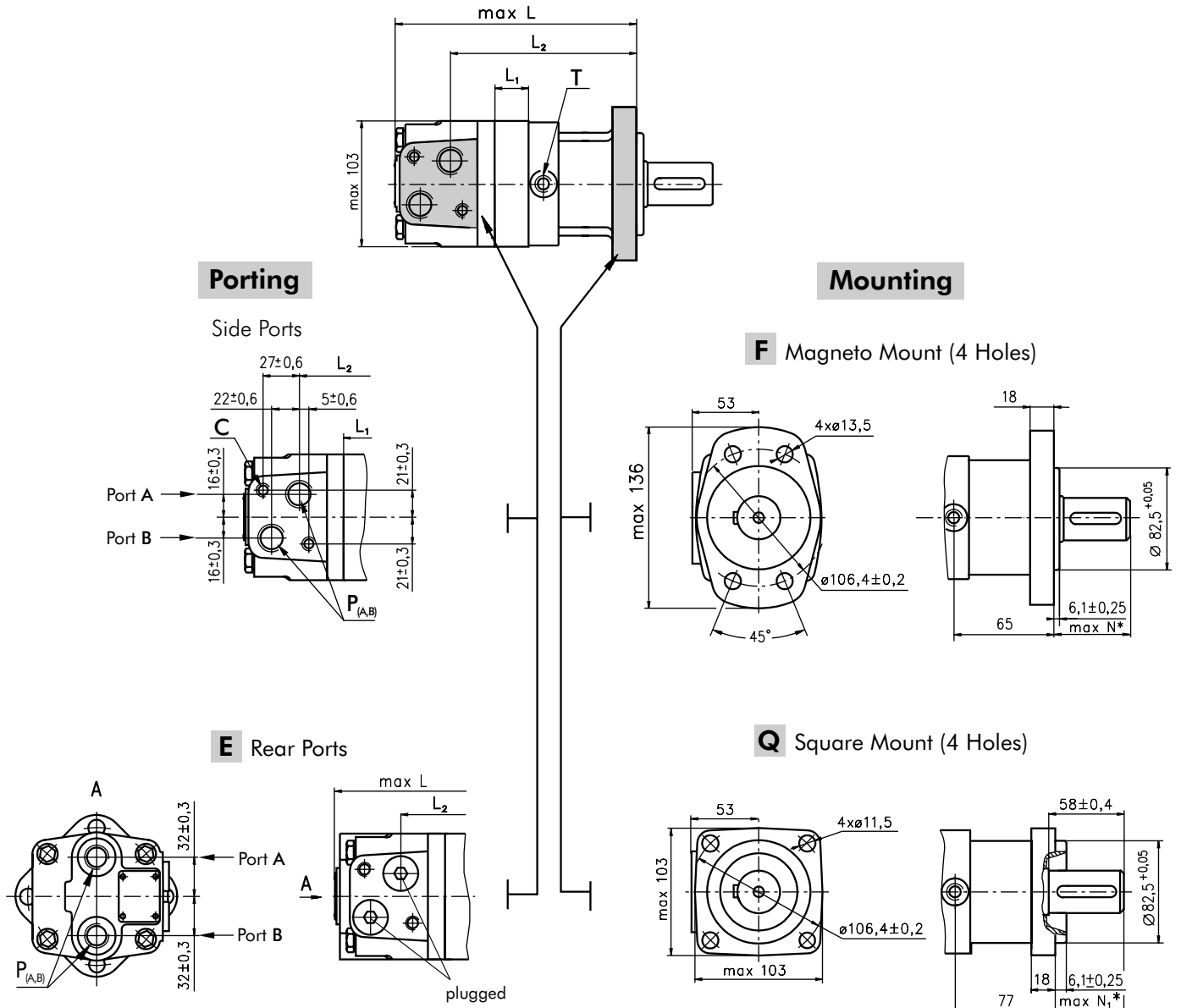

C: 2xM10-12 mm depth
P_(A,B): 2xG1/2 or 2xM22x1,5-15 mm depth
T: G ¼ or M14x1,5- 12 mm depth (plugged)

Standard Rotation
 Viewed from Shaft End
 Port A Pressurized - CW
 Port B Pressurized - CCW

*For **N** and **N₁**, see page 17
Reverse Rotation
 Viewed from Shaft End
 Port A Pressurized - CCW
 Port B Pressurized - CW

Type	L, mm	L ₂ , mm	Type	L, mm	L ₂ , mm	Type	L, mm	Type	L, mm	L ₁ , mm
MSF 80	168	124	MSQ 80	179	136	MSFE 80	173	MSQE 80	185	14
MSF 100	171	129	MSQ 100	183	140	MSFE 100	177	MSQE 100	189	17,4
MSF 125	176	132	MSQ 125	187	144	MSFE 125	181	MSQE 125	193	21,8
MSF 160	182	138	MSQ 160	193	150	MSFE 160	187	MSQE 160	199	27,8
MSF 200	189	145	MSQ 200	200	157	MSFE 200	194	MSQE 200	206	34,8
MSF 250	197	154	MSQ 250	209	166	MSFE 250	203	MSQE 250	215	43,5
MSF 315	209	165	MSQ 315	220	177	MSFE 315	214	MSQE 315	226	54,8
MSF 400	223	179	MSQ 400	235	192	MSFE 400	228	MSQE 400	241	69,4
MSF 475	237	193	MSQ 475	247	205	MSFE 475	242	MSQE 475	254	82,6
MSF 525	229	185	MSQ 525	240	197	MSFE 525	234	MSQE 525	246	74,5
MSF 565	235	191	MSQ 565	246	203	MSFE 565	240	MSQE 565	252	80,2

DIMENSIONS AND MOUNTING DATA -MSW

W Wheel Mount

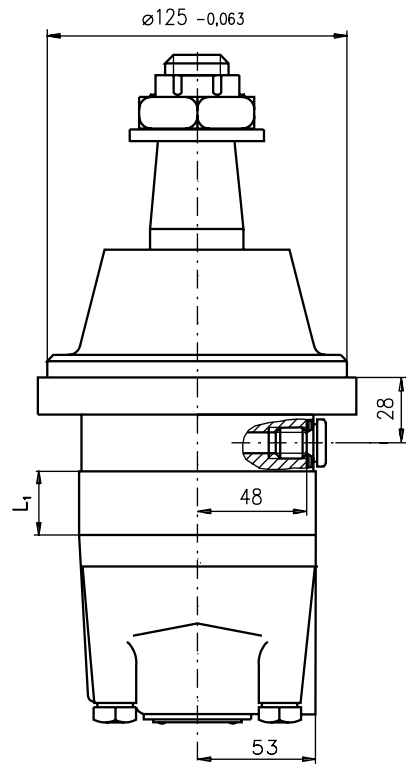
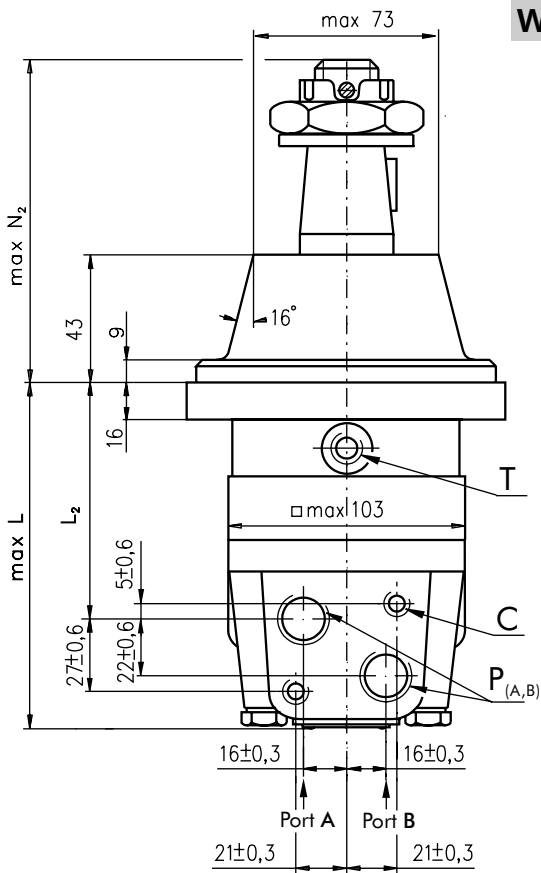

C: 2xM10-12 mm depth
P_(A,B): 2xG1/2 or 2xM22x1,5-15 mm depth
T: G 1/4 or M14x1,5 - 12 mm depth(plugged)

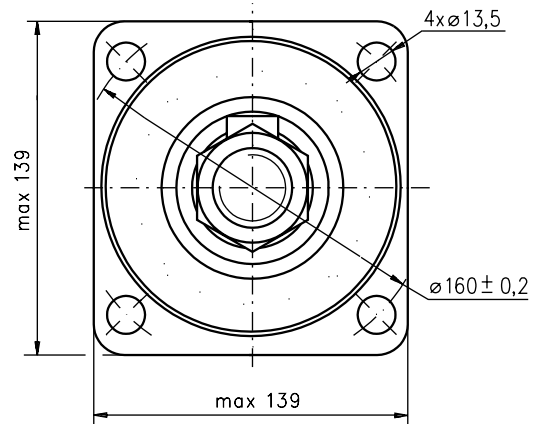

*For N₂ see page 17

E Rear Port

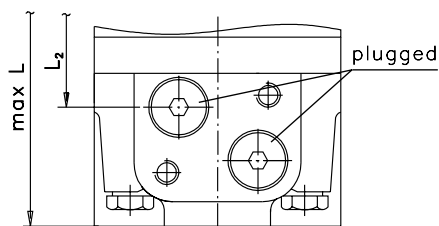
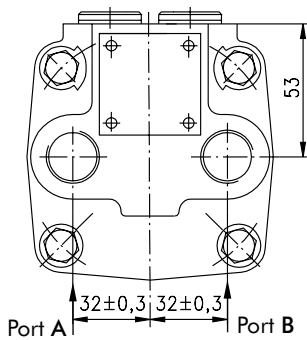

Standard Rotation
 Viewed from Shaft End
 Port A Pressurized - CW
 Port B Pressurized - CCW

Reverse Rotation
 Viewed from Shaft End
 Port A Pressurized - CCW
 Port B Pressurized - CW

Type	L ₁ , mm	L ₁ , mm	L ₂ , mm	Type	L, mm
MSW 80	129	14	87	MSWE 80	138
MSW100	133	17,4	91	MSWE 100	142
MSW 125	137	21,8	95	MSWE 125	146
MSW 160	143	27,8	101	MSWE 160	152
MSW 200	150	34,8	108	MSWE 200	159
MSW 250	159	43,5	117	MSWE 250	168
MSW 315	170	54,8	128	MSWE 315	179
MSW 400	184	69,4	143	MSWE 400	194
MSW 475	198	82,6	156	MSWE 475	207
MSW 525	190	74,5	148	MSWE 525	199
MSW 565	196	80,2	154	MSWE 565	205

B Motor with Drum Brake

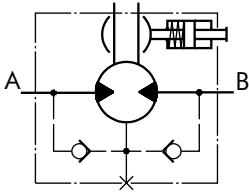

Actuating the brake level, the brake shaft is turned. The rectangular shape of the inner part of this shaft forces the brake pads to be pressed against the brake drum. This brakes the wheel or the winch drum.

Releasing the level, the springs pull it and the brake pads back to the initial position. The motor output shaft is released. Minimum angle adjustment is 10°. It can be adjusted by dismounting the level. Depending on the application You can choose the actuating direction of the brake level. The rod connection actuating the brake should be capable of moving at last 25 mm from neutral to extreme position.

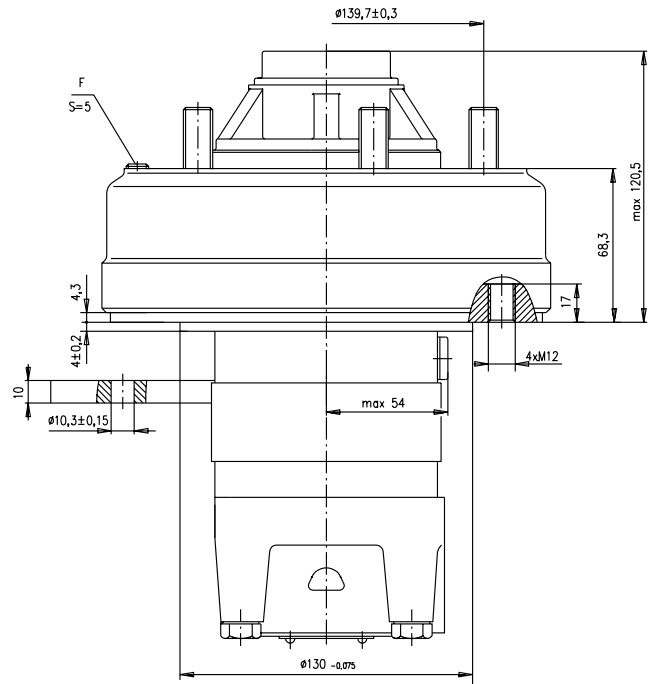
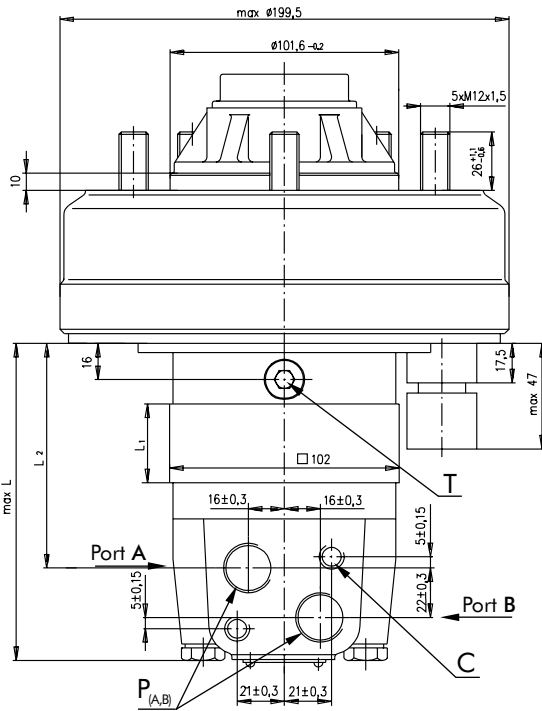
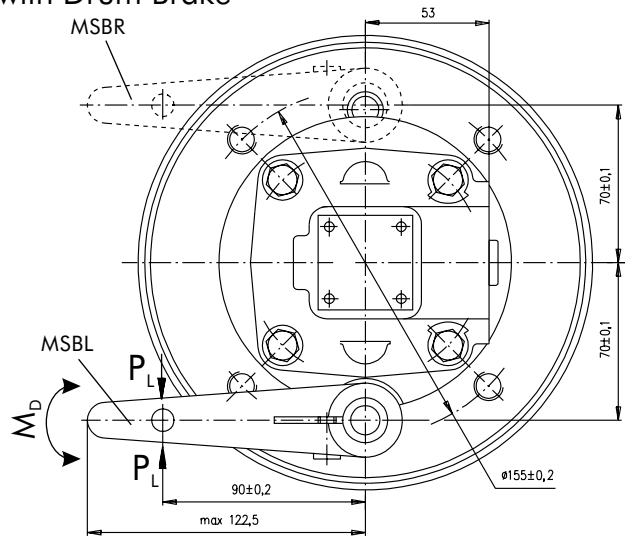

- C:** 2xM10-12 mm depth
- F:** Inspection hole for checking brake lining
- T:** G 1/4 or M14x1,5 - 12 mm depth (plugged)
- P_(A,B):** 2xG1/2 or 2xM22x1,5-15 mm depth

E Rear Port

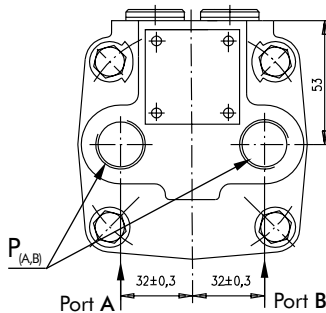

Standard Rotation
Viewed from Shaft End
Port A Pressurized - CW
Port B Pressurized - CCW

Reverse Rotation
Viewed from Shaft End
Port A Pressurized - CCW
Port B Pressurized - CW

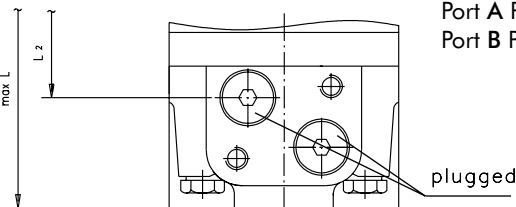

Type	L, mm	L ₁ , mm	L ₂ , mm	Type	L, mm
MSB 80	119	14	74	MSBE 80	127
MSB100	122	17,4	77	MSBE 100	130
MSB 125	126	21,8	82	MSBE 125	134
MSB 160	132	27,8	88	MSBE 160	140
MSB 200	139	34,8	95	MSBE 200	147
MSB 250	148	43,5	110	MSBE 250	156
MSB 315	159	54,8	115	MSBE 315	167
MSB 400	174	69,4	130	MSBE 400	182
MSB 475	188	82,6	143	MSBE 475	196
MSB 525	180	74,5	135	MSBE 525	188
MSB 565	186	80,2	141	MSBE 565	192

SHAFT EXTENSIONS

C - $\phi 32$ straight, Parallel key A10x8x45 DIN 6885
Max. Torque 77 daNm

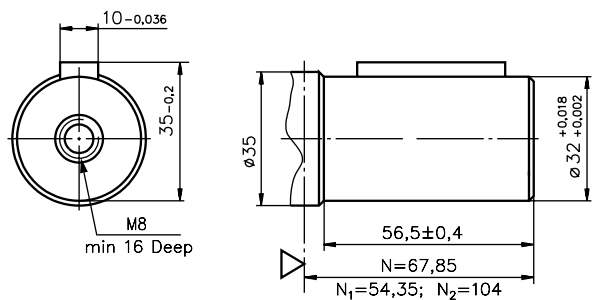

K - tapered 1:10, Parallel key B6x6x20 DIN 6885
Max. Torque 95 daNm

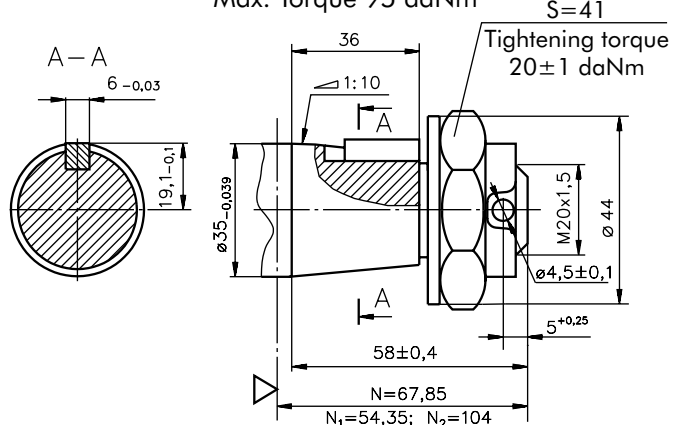

CO - $\phi 1\frac{1}{4}$ " straight, Parallel key $\frac{5}{16}$ "x $\frac{5}{16}$ "x $1\frac{1}{4}$ "BS46
Max. Torque 77 daNm

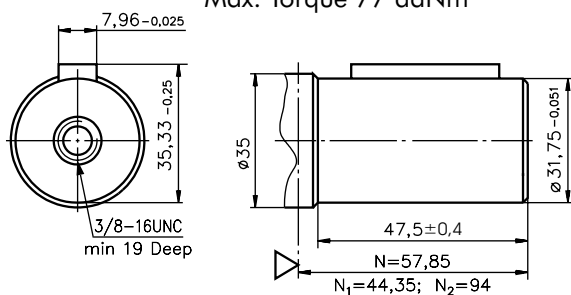

SH - $\phi 1\frac{1}{4}$ " splined 14T, DP12/24 ANSI B92.1-1976
Max. Torque 95 daNm

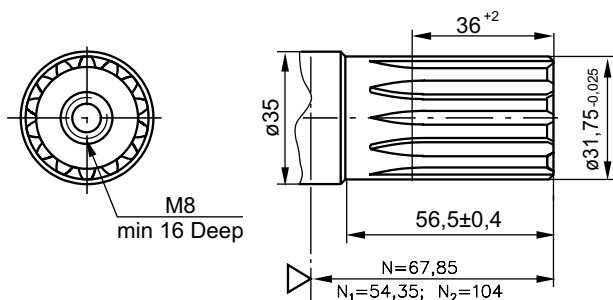

SL - $\phi 34.85$ p.t.o. DIN 9611 Form 1
Max. Torque 77 daNm

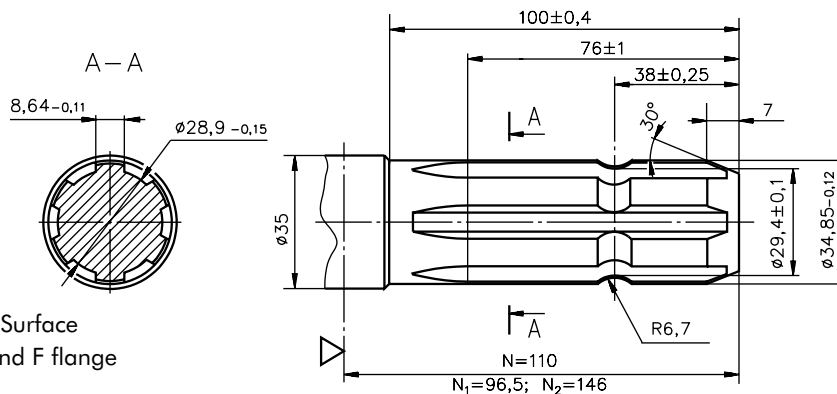

▽ - Motor Mounting Surface
N - for standart, A and F flange
N₁ - for Q flange
N₂ - for W flange

PERMISSIBLE SHAFT LOADS

The output shaft runs in tapered bearings that permit high axial and radial forces. Curve "1" shows max. radial shaft load. Any shaft load exceeding the values quoted in the curve will seriously reduce motor life. The two other curves apply to a B10 bearing life of 3000 hours at 200 RPM.

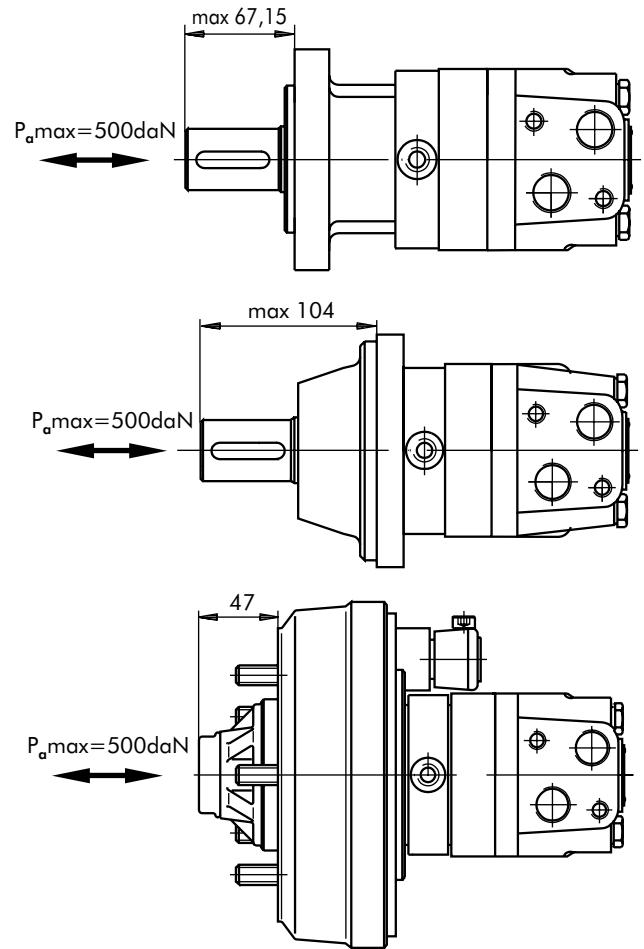
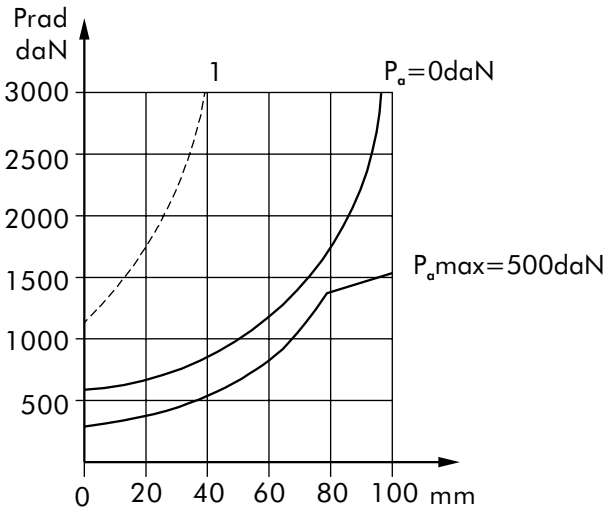

FUNCTION DIAGRAM MSB

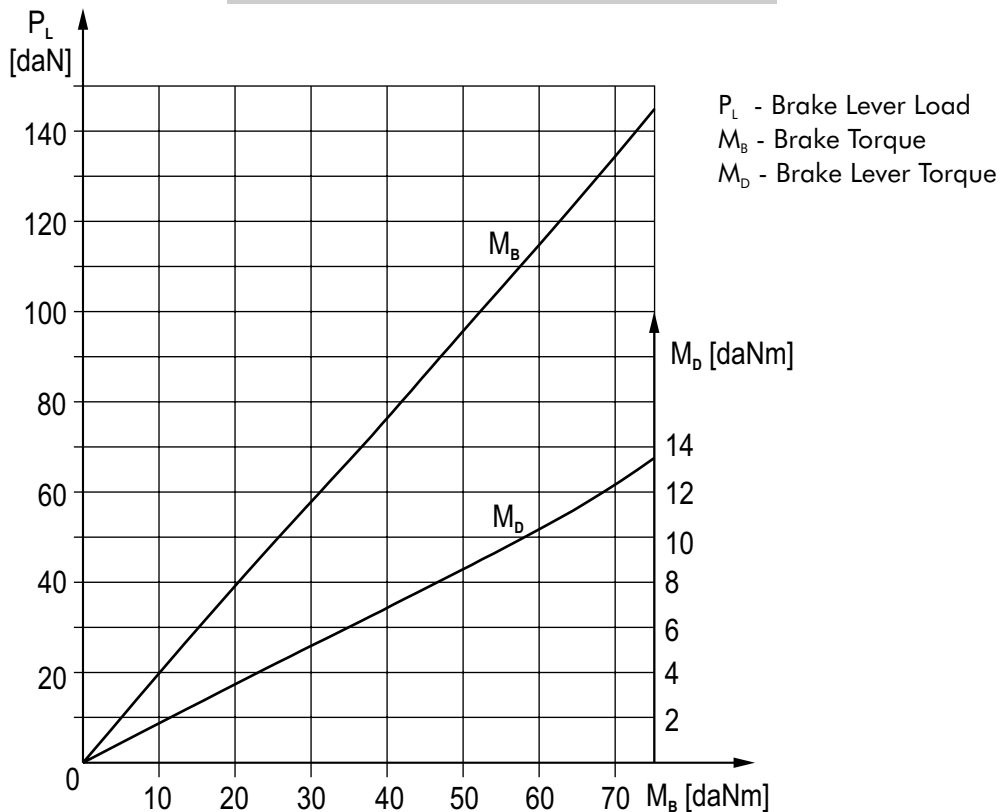

MAX. PERMISSIBLE SHAFT SEAL PRESSURE

**Max. return pressure without drain line or
max. pressure in the drain line**

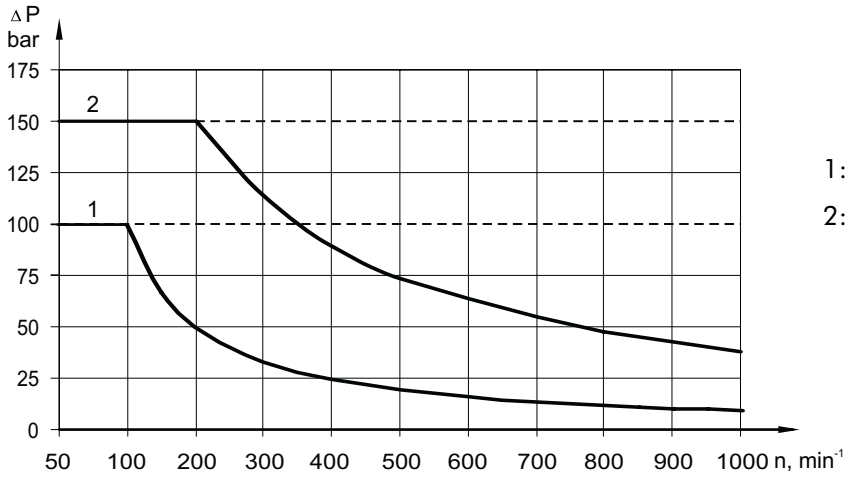

1: Drawing for Standard Shaft Seal
 2: Drawing for High Pressure Seal ("U" Seal)

— - continuous operations
 - - - - - intermittent operations

MOTORS WITH TACHO CONNECTION

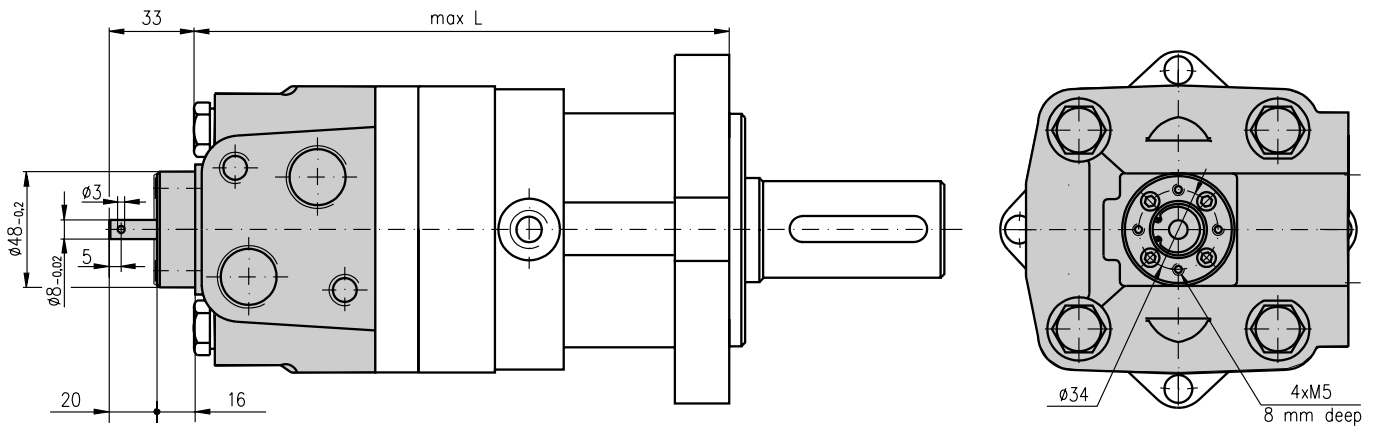

DIMENSIONS AND MOUNTING DATA - MSS, MSV and MSU

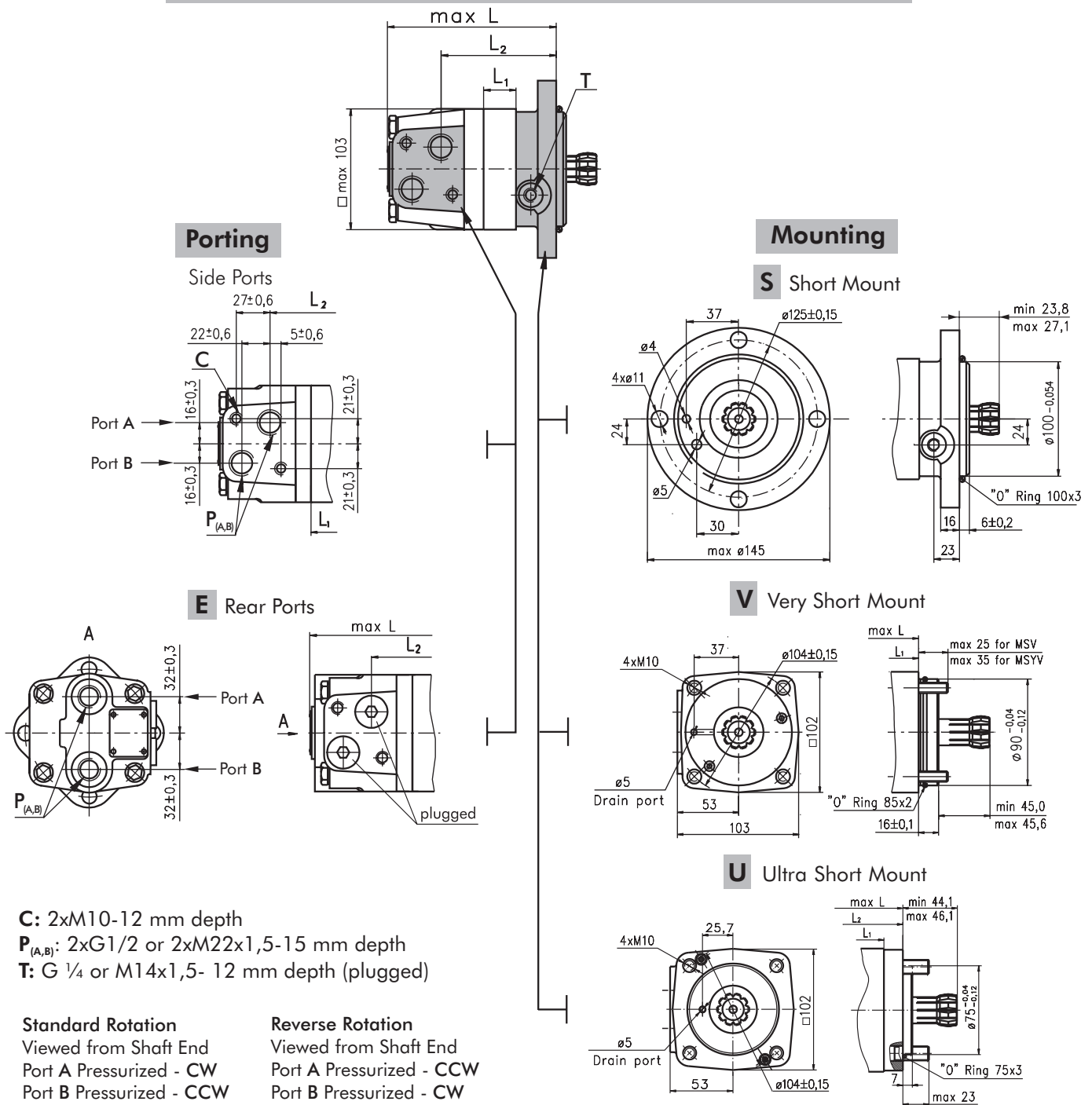

Type	L, mm	L ₂ , mm	Type	L, mm	Type	L, mm	L ₂ , mm	Type	L, mm	Type	L, mm	L ₂ , mm	Type	L, mm	L ₁ , mm
MSS 80	125	83	MSSE 80	134	MSV 80	91	52	MSVE 80	97	MSU 80	105,5	63	MSUE 80	111,5	14
MSS 100	129	87	MSSE 100	138	MSV 100	94	55,5	MSVE 100	100	MSU 100	109	66,5	MSUE 100	115	17,4
MSS 125	133	90	MSSE 125	141	MSV 125	100	60	MSVE 125	105	MSU 125	113	71	MSUE 125	119	21,8
MSS 160	139	96	MSSE 160	147	MSV 160	106	66	MSVE 160	111	MSU 160	119	77	MSUE 160	125	27,8
MSS 200	146	103	MSSE 200	154	MSV 200	113	73	MSVE 200	118	MSU 200	126	84	MSUE 200	132	34,8
MSS 250	155	112	MSSE 250	163	MSV 250	121	81,5	MSVE 250	126	MSU 250	135	92,5	MSUE 250	141	43,5
MSS 315	166	123	MSSE 315	174	MSV 315	133	93	MSVE 315	138	MSU 315	146	104	MSUE 315	152	54,8
MSS 400	181	138	MSSE 400	189	MSV 400	147	108	MSVE 400	153	MSU 400	160	119	MSUE 400	167	69,4
MSS 475	194	152	MSSE 475	203	MSV 475	161	121	MSVE 475	166	MSU 475	174	132	MSUE 475	180	82,6
MSS 525	186	144	MSSE 525	195	MSV 525	153	113	MSVE 525	158	MSU 525	166	124	MSUE 525	172	74,5
MSS 565	192	150	MSSE 565	201	MSV 565	159	119	MSVE 565	164	MSU 565	172	130	MSUE 565	178	80,2

DIMENSIONS OF THE ATTACHED COMPONENT

For MSS

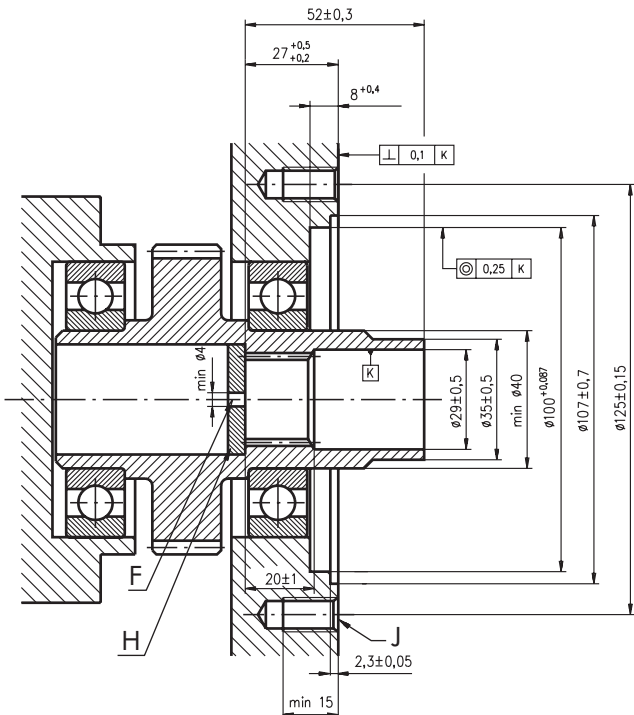

- F:** Oil circulation hole
- H:** Hardened stop plate
- J:** 4xM10-16 mm depth, 90°

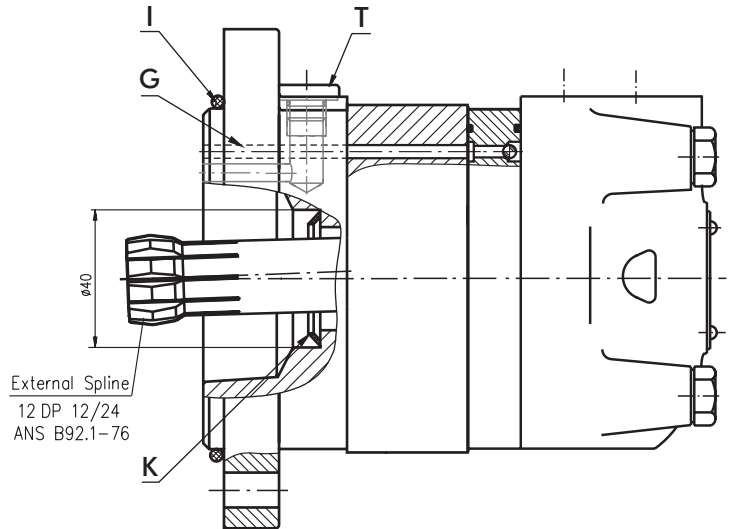

External Spline
12 DP 12/24
ANS B92.1-76

- G:** Internal drain channel
- I:** O- Ring 100x3mm
- K:** Conical seal ring
- T:** Drain connection G1/4 or M14x1,5

For MSV

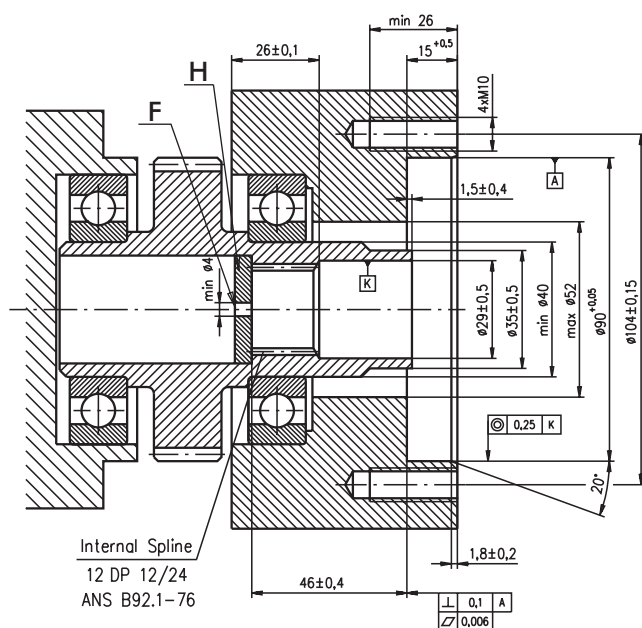

Internal Spline
12 DP 12/24
ANS B92.1-76

- F:** Oil circulation hole
- H:** Hardened stop plate

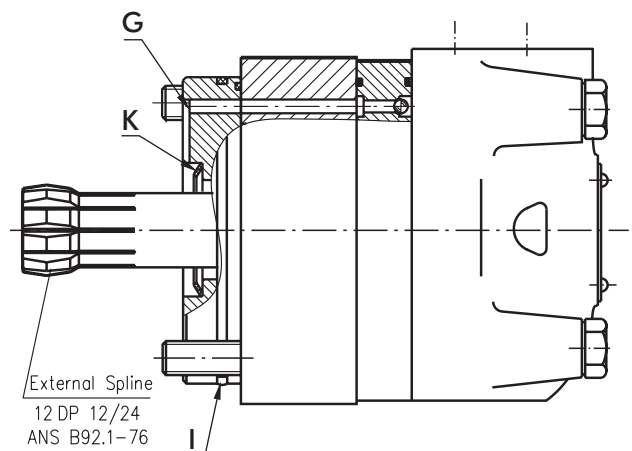

External Spline
12 DP 12/24
ANS B92.1-76

- G:** Internal drain channel
- I:** O- Ring 85x2 mm
- K:** Conical seal ring

DIMENSIONS OF THE ATTACHED COMPONENT(continued)

For MSU

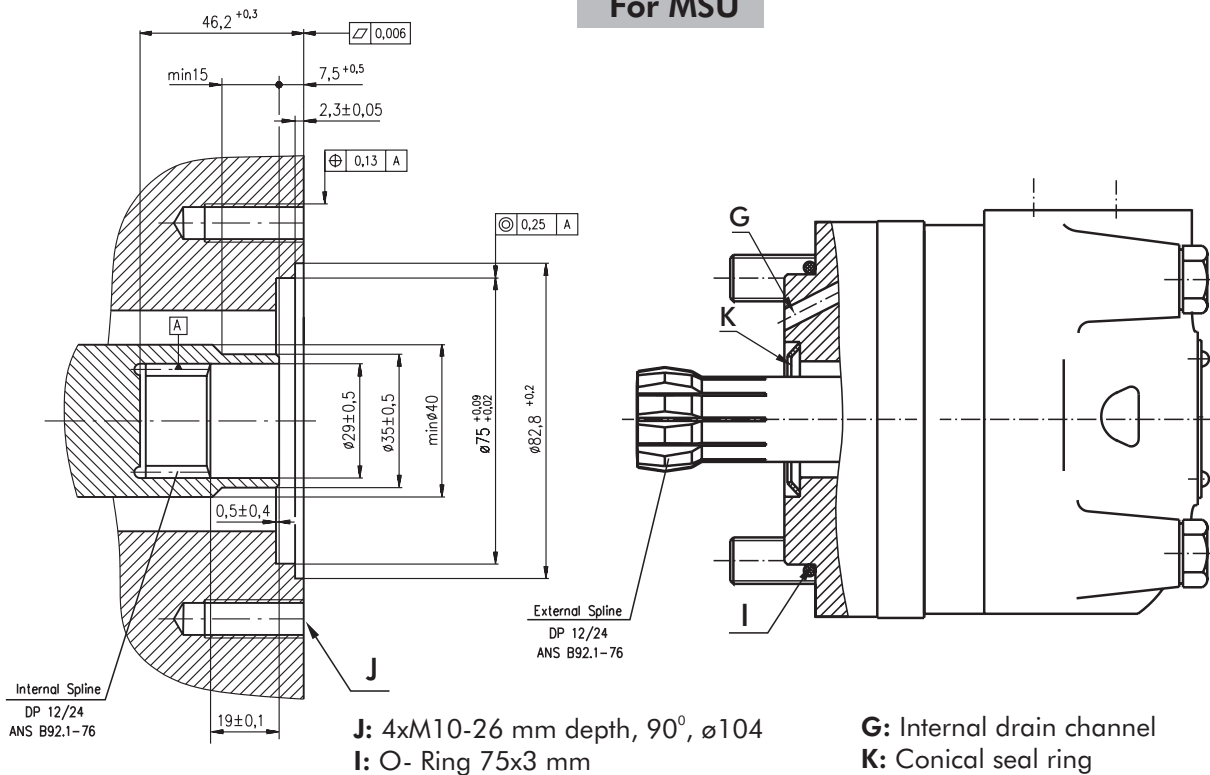

DRAIN CONNECTION

A drain line ought to be used when pressure in the return line can exceed the permissible pressure. It can be connected:

- For MSS at the drain port of the motor;
- For MSV and MSU at the drain connection of the attached component. The maximum pressure in the drain line is limited by the attached component and its shaft seal.

The drain line must be possible for oil to flow freely between motor and attached component and must be led to the tank. The maximum pressure in the drain line is limited by the attached component and its seal.

INTERNAL SPLINE DATA FOR THE ATTACHED COMPONENT

Standard ANS B92.1-1976, class 5
 [m=2.1166; corrected x.m=+0,8]

Fillet Root Side Fit		mm
Number of Teeth	z	12
Diametral Pitch	DP	12/24
Pressure Angle		30°
Pitch Dia.	D	25,4
Major Dia.	D _{ri}	28,0 _{0,1}
Minor Dia.	D _i	23,0 ^{+0,033}
Space Width [Circular]	L _o	4,308 ± 0,020
Fillet Radius	R	0,2
Max. Measurement between Pin	L	17,62 ^{+0,15}
Pin Dia.	d	4,835 ± 0,001

Above are when hardened

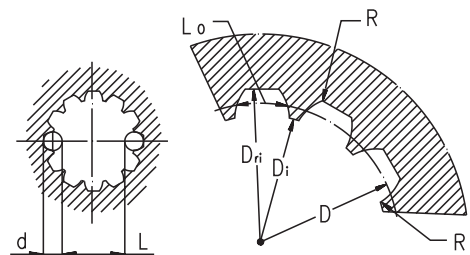

Hardening Specification:
 HV=750±50 on the surface
 HV=560 at 0,7±0,2 mm case depth
 Material 20 MoCr4 EN 10084 or better

ORDER CODE

	1	2	3	4	5	6	7	8	9
MS									

Pos. 1 - Mounting Flange

- omit - SAE A-4 mount, four holes
- A** - SAE A-2 mount, two holes
- F** - Magneto mount, four holes
- Q** - Square mount, four holes
- B** - Motor with drum brake
- S** - Short mount
- V** - Very short mount
- U** - Ultra short mount
- W** - Wheel mount

Pos. 2 - Port type

- omit - Side ports
- E** - Rear ports

Pos. 3 - Displacement code

- 80** - 80,5 [cm³/rev]
- 100** - 100,0 [cm³/rev]
- 125** - 125,7 [cm³/rev]
- 160** - 159,7 [cm³/rev]
- 200** - 200,0 [cm³/rev]
- 250** - 250,0 [cm³/rev]
- 315** - 314,9 [cm³/rev]
- 400** - 397,0 [cm³/rev]
- 475** - 474,6 [cm³/rev]
- 525** - 522,7 [cm³/rev]
- 565** - 564,9 [cm³/rev]

Pos. 4 - Shaft Extensions*

- omit - for **B**, **S**, **U** and **V** mounting flange
- C** - ø32 straight, Parallel key A10x8x45 DIN6885
- CO** - ø1 1/4" straight, Parallel key 5/16" x 5/16" x 1 1/4" BS46
- K** - ø35 tapered 1:10, Parallel key B6x6x20 DIN6885
- SL** - ø34,85 p.t.o. DIN 9611 Form 1
- SH** - ø1 1/4" splined 14T ANSI B92.1-1976

Pos. 5 - Shaft Seal Version (see page 19)

- omit - Low pressure seal
- U** - High pressure seal

Pos. 6 - Ports

- omit - BSPP (ISO 228)
- M** - Metric (ISO 262)

Pos. 7 - Actuating Direction**

- /R** - Right
- /L** - Left

Pos. 8 - Special Features (see page 65)

Pos. 9 - Design Series

- omit - Factory specified

NOTES:

- * The permissible output torque for shafts must not be exceeded!
- ** Only for MSB

The hydraulic motors are mangano-phosphatized as standard.

HYDRAULIC MOTORS MSY

MSY is the new hydraulic motor in a family of "disc valve" series which has dimensions and mounting data the same as at hydraulic motors type MS.

This motor is described with 15÷20% higher technical data-max. Torque and max. Pressure drop, thereby higher power. This makes it suitable for vehicles with greater loads and speed drop.



CONTENTS

Specification data	25
Function diagrams	26÷28
Dimensions and mounting	13÷14
Wheel motor	15
Motor with Drum Brake - MSYB	16
Shaft extensions	17
Permissible shaft loads	18
Function diagram for MSYB	18
Permissible Shaft Seal Pressure.....	19
Dimensions and mounting- MSYS, V	29
Internal Spline data	30
Order code	30

OPTIONS

- » Model- Disc valve, roll-gerotor
- » Flange and wheel mount
- » Short motor
- » Side and rear ports
- » Shafts- straight, splined and tapered
- » Other special features

GENERAL

Displacement, [cm ³ /rev.]	200 ÷ 474,6
Max. Speed, [RPM]	155 ÷ 375
Max. Torque, [daNm]	56,6 ÷ 91
Max. Output, [kW]	9 ÷ 18,1
Max. Pressure Drop, [bar]	140 ÷ 200
Max. Oil Flow, [l/min]	75
Min. Speed, [RPM]	5 ÷ 8
Permissible Shaft Loads, [daN]	P _a = 500
Pressure fluid	Mineral based- HLP(DIN 51524) or HM(ISO 6743/4)
Temperature range, [°C]	-30 ÷ 90
Optimal Viscosity range, [mm ² /s]	20 ÷ 75
Filtration	ISO code 20/16 (Min. recommended fluid filtration of 25 micron)

Oil flow in drain line

Pressure drop (bar)	Viscosity (mm ² /s)	Oil flow in drain line (l/min)
140	20	1,5
	35	1
210	20	3
	35	2

Pressure Losses

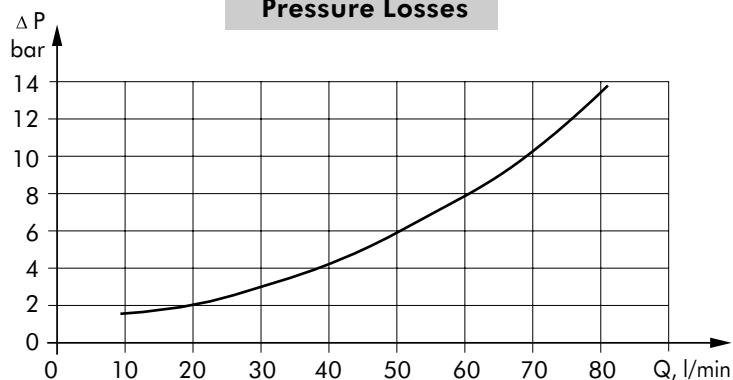

SPECIFICATION DATA FOR MSY

Type	MSY 200	MSY 250	MSY 315	MSY 400	MSY 475	
Displacement [cm ³ /rev.]	200	250	314,9	397	474,6	
Max. Speed, [RPM]	cont.	375	300	240	185	155
	Int.*	450	360	285	225	185
Max. Torque [daNm]	cont.	56,6	70,8	90,0	90,0	91
	Int.*	64,5	80,6	96,0	97,0	96
	peak**	65	80,6	108	110	100
Max. Output [kW]	cont.	18,1	18,0	17	11,0	9,0
	int.*	24,0	23,8	20,2	12	11,0
Max. Pressure Drop [bar]	cont.	200	200	200	160	140
	Int.*	225	225	220	175	150
	peak**	225	225	225	200	175
Max. Oil Flow [l/min]	cont.	75	75	75	75	75
	Int.*	90	90	90	90	90
Max. Inlet Pressure [bar]	cont.	210	210	210	210	210
	Int.*	250	250	250	250	250
	peak**	300	300	300	300	300
Max. Return Pressure with Drain Line [bar]	cont.	140	140	140	140	140
	Int.*	175	175	175	175	175
	peak**	210	210	210	210	210
Max. Starting Pressure with Unloaded Shaft, [bar]	8	8	8	8	8	
Min. Starting Torque [daNm]	at max. press. drop cont.	46,2	58,0	73,8	72,0	47
	at max. press. drop Int.*	50,7	63,6	79,2	78,7	55
Min. Speed***, [RPM]	6	6	5	5	5	
Weight, [kg]	MSY (F)	11,2	11,7	12,4	13,3	14,4
For Rear Ports	MSYW	11,7	12,2	12,9	13,8	15,0
+0,4 kg	MSYQ	11,6	12,1	12,8	13,7	14,9

* Intermittent operation: the permissible values may occur for max. 10% of every minute.

** Peak load: the permissible values may occur for max. 1% of every minute.

*** For speeds of 5 RPM lower than given, consult factory or your regional manager.

- 1) Intermittent speed and intermittent pressure must not occur simultaneously.
- 2) Recommended filtration is per ISO cleanliness code 20/16. A nominal filtration of 25 micron or better.
- 3) Recommend using a premium quality, anti-wear type mineral based hydraulic oil HLP(DIN51524) or HM (ISO 6743/4). If using synthetic fluids consult the factory for alternative seal materials.
- 4) Recommended minimum oil viscosity 13 mm²/s at operating temperatures.
- 5) Recommended maximum system operating temperature is 82°C.
- 6) To assure optimum motor life fill with fluid prior to loading and run at moderate load and speed for 10-15 minutes.

FUNCTION DIAGRAMS

MSY 200

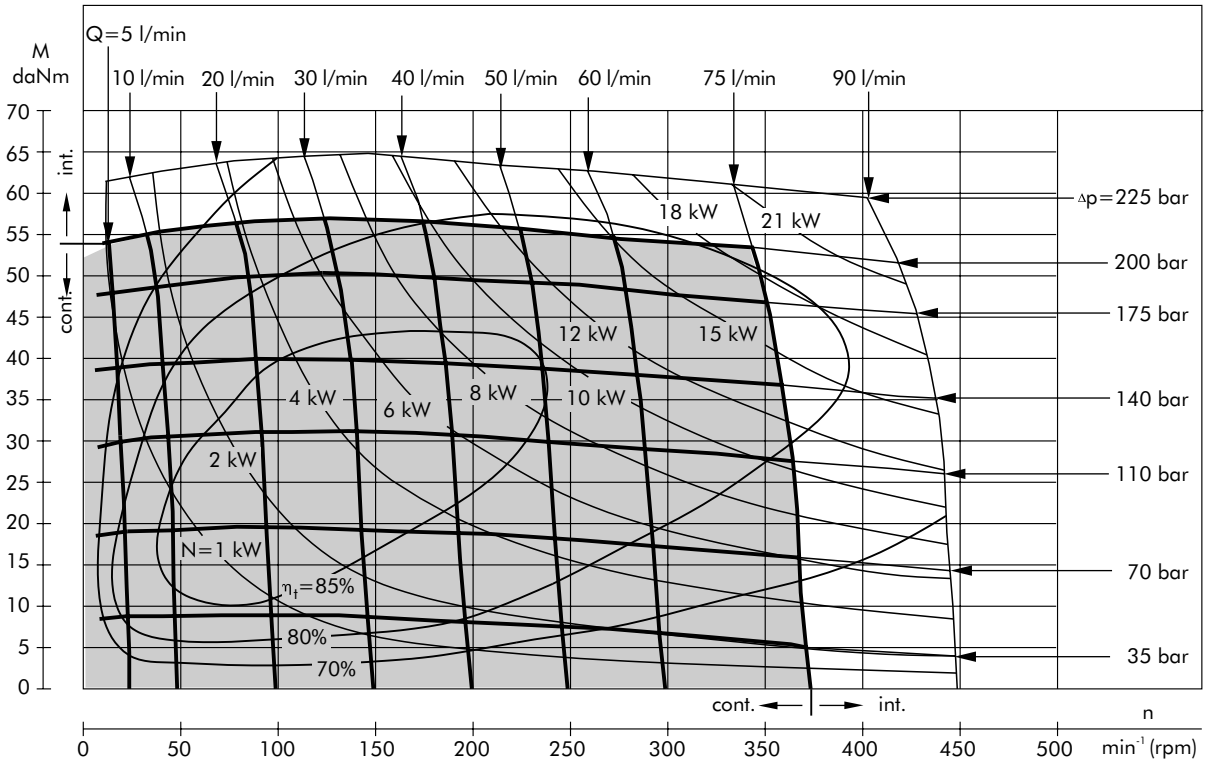

MSY 250

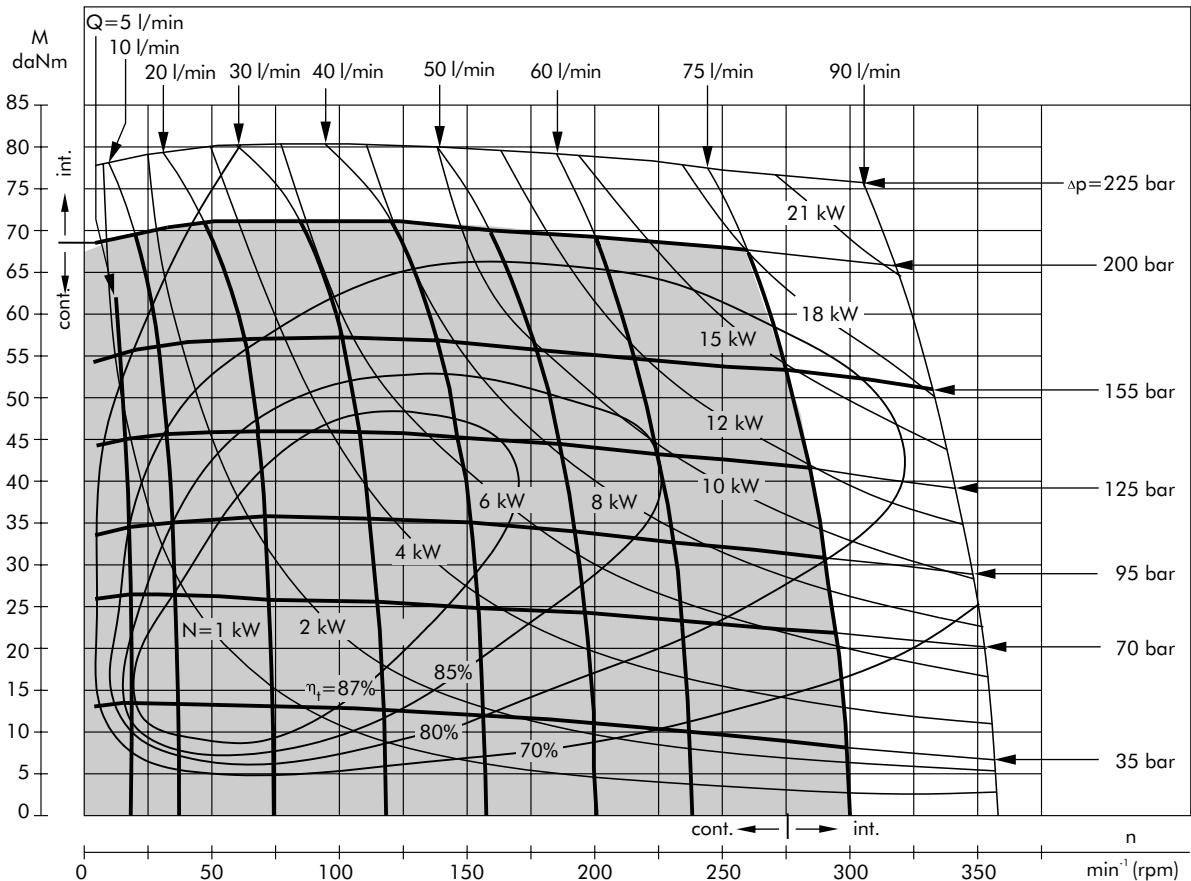

The function diagrams data was collected at back pressure 5 ÷ 10 bar and oil with viscosity of 32 mm^2/s at 50° C.

FUNCTION DIAGRAMS

MSY 315

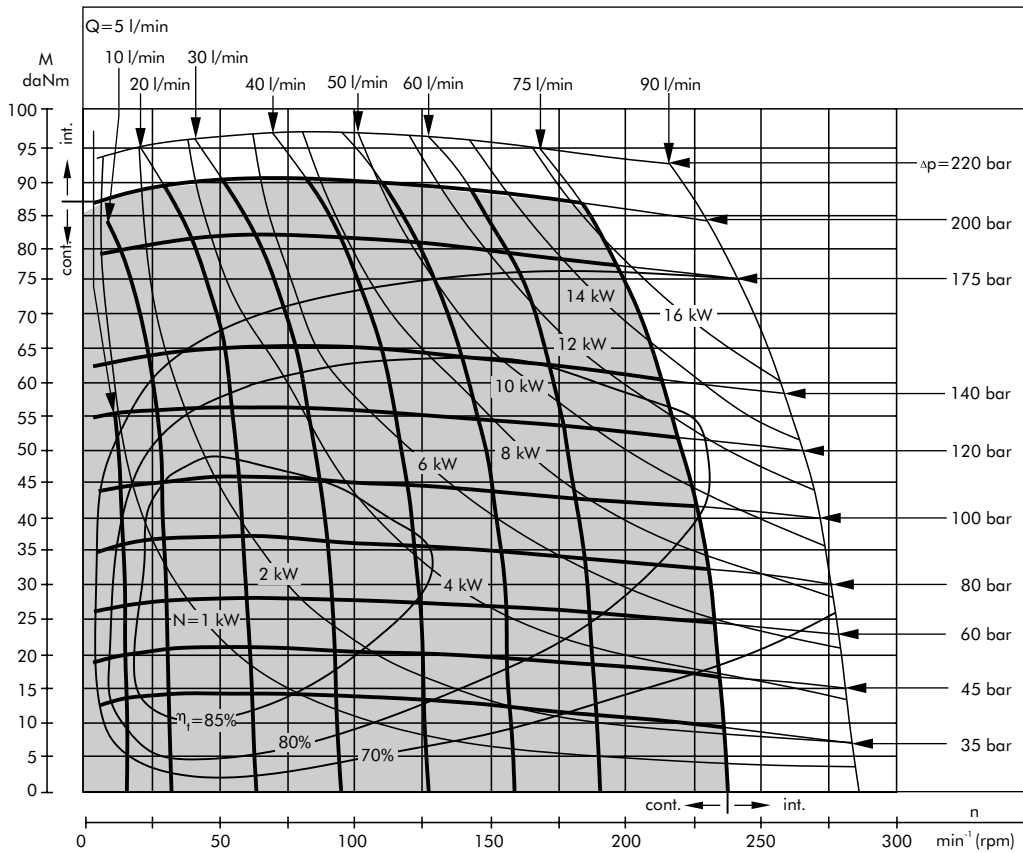

MSY 400

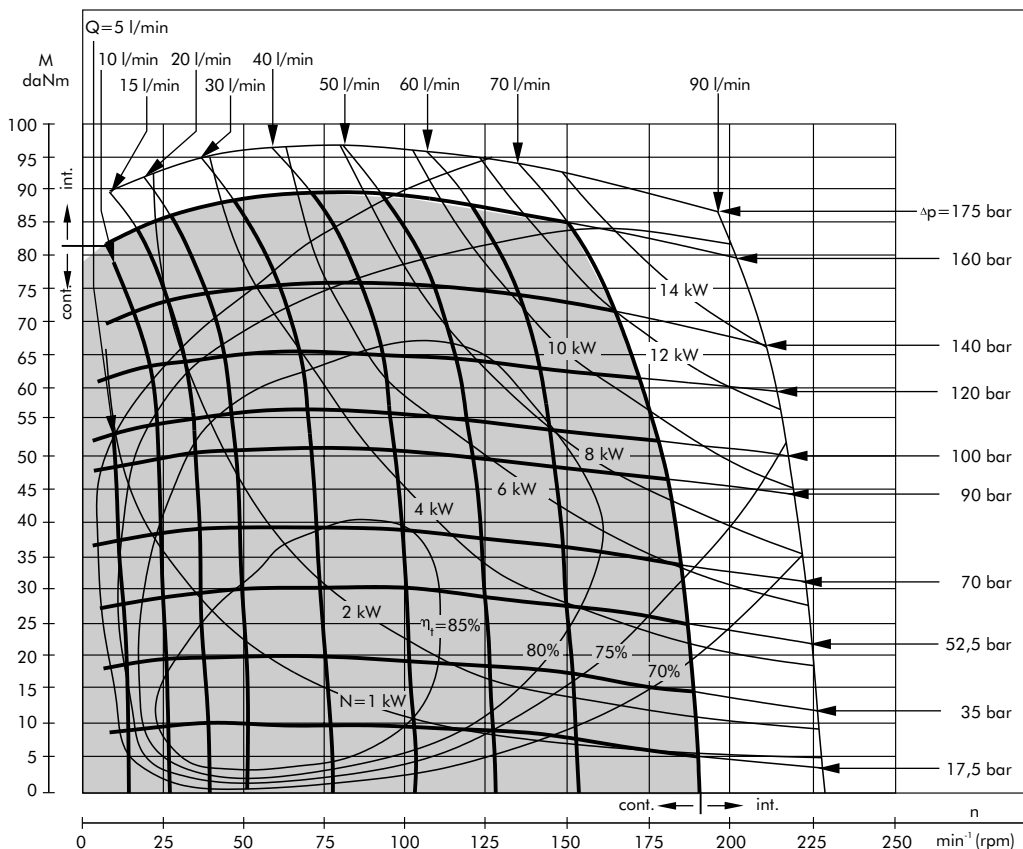

The function diagrams data was collected at back pressure 5 ÷ 10 bar and oil with viscosity of 32 mm²/s at 50° C.

FUNCTION DIAGRAMS

MSY 475

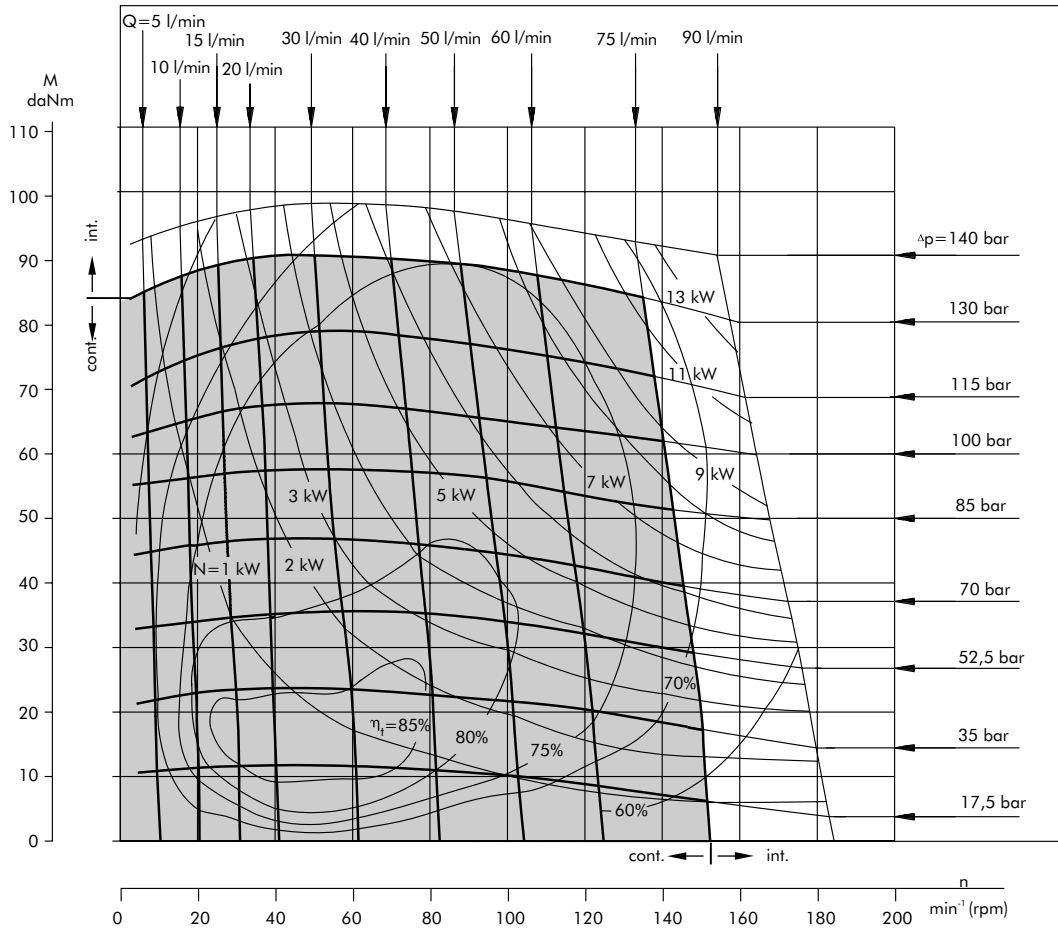

The function diagrams data was collected at back pressure 5 ÷ 10 bar and oil with viscosity of 32 mm²/s at 50° C.

The dimensions, mounting data, shaft extensions and permissible shaft loads are the same as at hydraulic motors type MS except following below.

DIMENSIONS OF THE ATTACHED COMPONENT

For MSYS

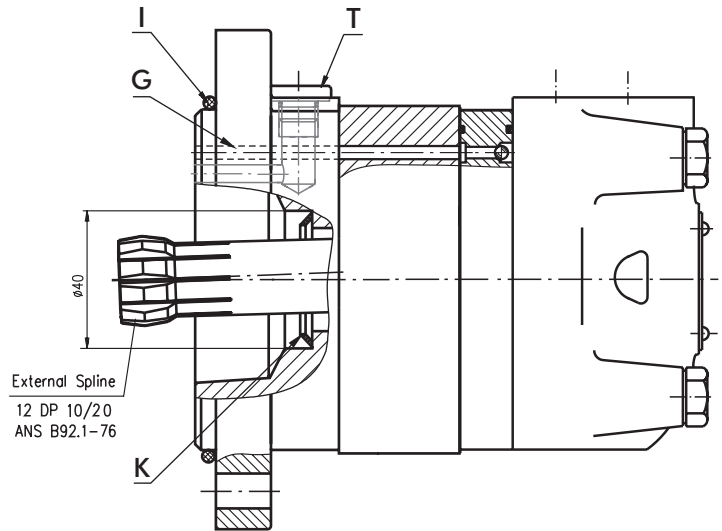
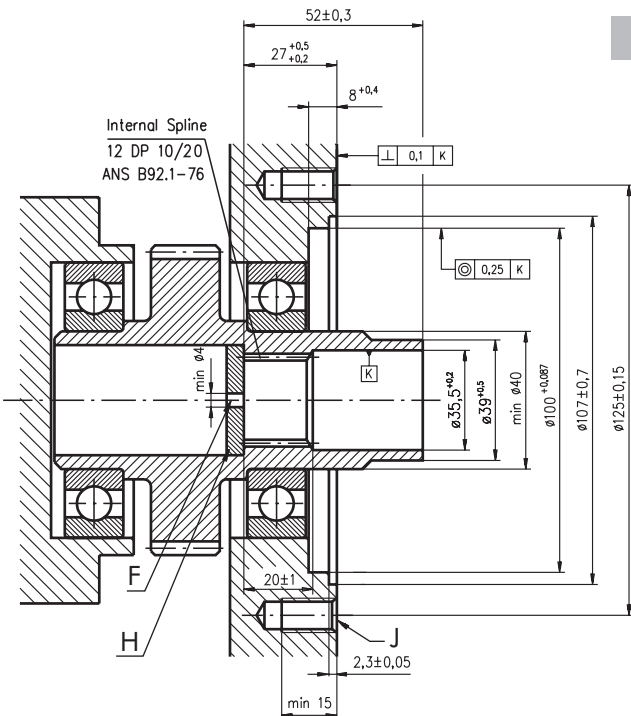

- F:** Oil circulation hole
- H:** Hardened stop plate
- J:** 4xM10-16 mm depth, 90°

- G:** Internal drain channel
- I:** O- Ring 100x3mm
- K:** Conical seal ring
- T:** Drain connection G1/4 or M14x1,5

For MSYV

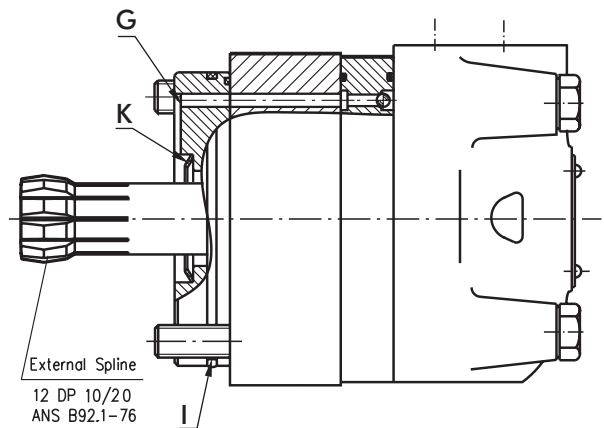
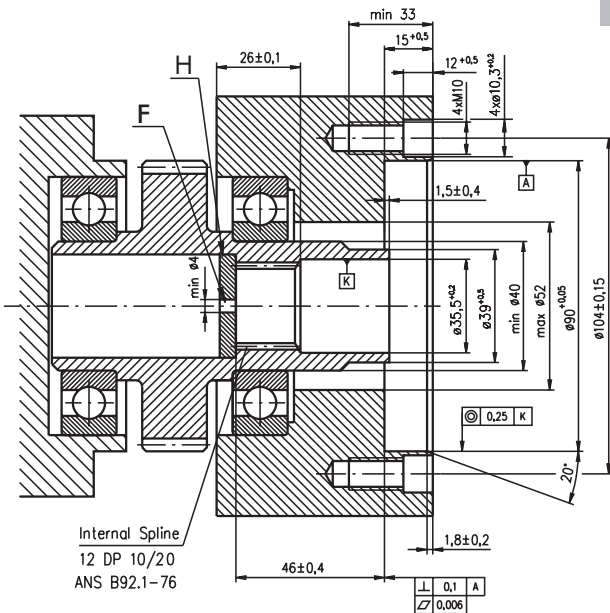

- F:** Oil circulation hole
- G:** Internal drain channel

- H:** Hardened stop plate
- I:** O- Ring 85x2mm
- K:** Conical seal ring

DRAIN CONNECTION

A drain line ought to be used when pressure in the return line can exceed the permissible pressure. It can be connected:

- For MSYS at the drain port of the motor;
- For MSYV at the drain connection of the attached component. The maximum pressure in the drain line is limited by the attached component and its shaft seal.

The drain line must be possible for oil to flow freely between motor and attached component and must be led to the tank. The maximum pressure in the drain line is limited by the attached component and its seal.

INTERNAL SPLINE DATA FOR THE ATTACHED COMPONENT

Standard 12 DP 10/20 ANS B92.1-1976, class 5
[$m=2.54$; corrected $x.m=+0,4$]

Fillet Root Side Fit		mm
Number of Teeth	z	12
Diametral Pitch	DP	10/20
Pressure Angle		30°
Pitch Dia.	D	30,48
Major Dia.	D _{ri}	33,2 ^{+0,2}
Minor Dia.	D _i	27,8 ^{+0,1}
Space Width [Circular]	L _o	4,45 ^{+0,071} _{+0,026}
Fillet Radius	R _{min}	0,2
Max. Measurement between Pin	L	23,39 ^{+0,17} _{+0,06}
Pin Dia.	d	4,835±0,001

Above are when hardened

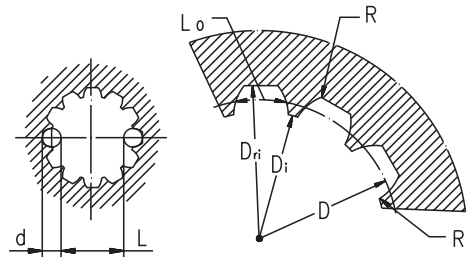

Hardening Specification:
HV=750±50 on the surface
HV=560 at 0,7±0,2 mm case depth
Material 20 MoCr4 EN 10084 or better

ORDER CODE

	1	2	3	4	5	6	7	8	9
MSY									

Pos. 1 - Mounting Flange

- omit - SAE A-4 mount, four holes
- A** - SAE A-2 mount, two holes
- F** - Magneto mount, four holes
- Q** - Square mount, four holes
- B** - Motor with drum brake
- S** - Short mount
- V** - Very short mount
- W** - Wheel mount

Pos. 2 - Port type

- omit - Side ports
- E** - Rear ports

Pos. 3 - Displacement code

- 200** - 200,0 [cm³/rev]
- 250** - 250,0 [cm³/rev]
- 315** - 314,9 [cm³/rev]
- 400** - 397,0 [cm³/rev]
- 475** - 474,5 [cm³/rev]

Pos. 4 - Shaft Extensions*

- omit - for **B**, **S** and **V** mounting flange
- C** - ø32 straight, Parallel key A10x8x45 DIN6885
- K** - ø35 tapered 1:10, Parallel key B6x6x20 DIN6885
- SL** - ø34,85 p.t.o. DIN 9611 Form 1
- SH** - ø1¼" splined 14T ANS B92.1-1976

Pos. 5 - Shaft Seal Version (see page 19)

- omit - Low pressure seal
- U** - High pressure seal

Pos. 6 - Ports

- omit - BSPP (ISO 228)
- M** - Metric (ISO 262)

Pos. 7 - Actuating Direction**

- /R** - Right
- /L** - Left

Pos. 8 - Special Features (see page 65)

Pos. 9 - Design Series

- omit - Factory specified

NOTES:

* The permissible output torque for shafts must not be exceeded!

** Only for MSYB

The hydraulic motors are manganophosphatized as standard.

HYDRAULIC MOTORS MT



APPLICATION

- » Conveyors
- » Metal working machines
- » Machines for agriculture
- » Road building machines
- » Mining machinery
- » Food industries
- » Special vehicles
- » Plastic and rubber machinery etc.

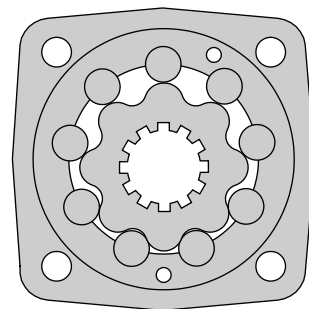

CONTENTS

Specification data	32
Function diagrams	33÷36
Dimensions and mounting	37
Shaft extensions	38
Permissible Shaft Seal pressure	38
Dimensions and mounting- MTS, V	39÷40
Internal Spline data	41
Permissible shaft loads	41
Tacho connection	42
Order code	42

OPTIONS

- » Model- Disc valve, roll-gerotor
- » Flange with wheel mount
- » Short motor
- » Tacho connection
- » Speed sensing
- » Side and rear ports
- » Shafts- straight, splined and tapered
- » Metric and BSPP ports
- » Other special features

GENERAL

Displacement,	[cm ³ /rev.]	161,1 ÷ 725
Max. Speed,	[RPM]	175 ÷ 625
Max. Torque,	[daNm]	47 ÷ 125
Max. Output,	[kW]	20,2 ÷ 33,5
Max. Pressure Drop,	[bar]	115 ÷ 200
Max. Oil Flow,	[l/min]	100 ÷ 125
Min. Speed,	[RPM]	5 ÷ 10
Permissible Shaft Loads,	[daN]	P ₀ = 1000
Pressure fluid	Mineral based- HLP(DIN 51524) or HM(ISO 6743/4)	
Temperature range,	[°C]	-30 ÷ 90
Optimal Viscosity range,	[mm ² /s]	20 ÷ 75
Filtration	ISO code 20/16 (Min. recommended fluid filtration of 25 micron)	

Oil flow in drain line

Pressure drop (bar)	Viscosity (mm ² /s)	Oil flow in drain line (l/min)
140	20	2,5
	35	1,5
210	20	5
	35	3

Pressure Losses

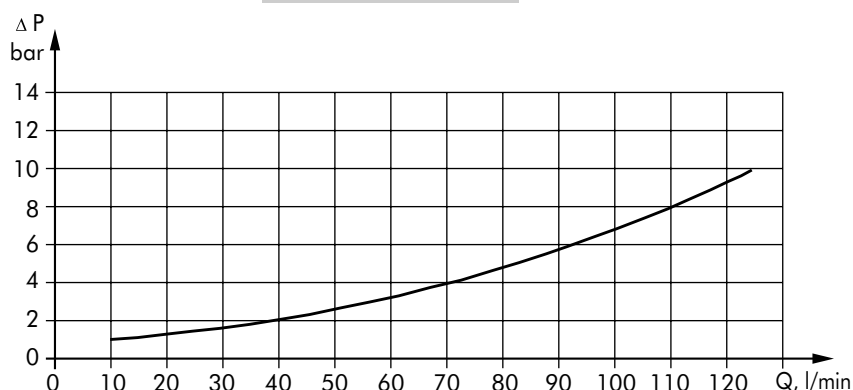

SPECIFICATION DATA

Type	MT 160	MT 200	MT 250	MT 315	MT 400	MT 500	MT 630	MT 725	
Displacement [cm ³ /rev.]	161,1	201,4	251,8	326,3	410,9	523,6	631,2	724,3	
Max. Speed, [RPM]	cont.	625	625	500	380	305	240	197	164
	Int.*	780	750	600	460	365	285	234	199
Max. Torque [daNm]	cont.	47	59	73	95	108	122	138	153
	Int.*	56	71	88	114	126	137	155	172
	peak**	66	82	102	133	144	160	180	200
Max. Output [kW]	cont.	26,5	33,5	33,5	33,5	30	26,5	24,3	20,2
	int.*	32	40	40	40	35	30	27,5	26,8
Max. Pressure Drop [bar]	cont.	200	200	200	200	180	160	140	120
	Int.*	240	240	240	240	210	180	160	140
	peak**	280	280	280	280	240	210	190	165
Max. Oil Flow [l/min]	cont.	100	125	125	125	125	125	125	125
	Int.*	125	150	150	150	150	150	151,4	151,4
Max. Inlet Pressure [bar]	cont.	210	210	210	210	210	210	210	210
	Int.*	250	250	250	250	250	250	250	250
	peak**	300	300	300	300	300	300	300	300
Max. Return Pressure with Drain Line [bar]	cont.	140	140	140	140	140	140	140	140
	Int.*	175	175	175	175	175	175	175	175
	peak**	210	210	210	210	210	210	210	210
Max. Starting Pressure with Unloaded Shaft, [bar]	10	10	10	10	10	10	10	10	
Min. Starting Torque [daNm]	at max. press. drop cont.	34	43	53	74	84	95	95	95
	at max. press. drop Int.*	41	52	63	89	97	106	110	115
Min. Speed***, [RPM]	10	9	8	7	6	5	5	5	
Weight, [kg] For Rear Ports +0,45 kg	MT	20	20,5	21	22	23	24	23,5	24,5
	MTW	22	22,5	23	24	25	26	25,5	26,5
	MTS	15	15,5	16	17	18	19	18,5	19,5
	MTV	11	11,5	12	13	14	15	14,5	15,5

* Intermittent operation: the permissible values may occur for max. 10% of every minute.

** Peak load: the permissible values may occur for max. 1% of every minute.

*** For speeds of 5 RPM lower than given, consult factory or your regional manager.

- 1) Intermittent speed and intermittent pressure must not occur simultaneously.
- 2) Recommended filtration is per ISO cleanliness code 20/16. A nominal filtration of 25 micron or better.
- 3) Recommend using a premium quality, anti-wear type mineral based hydraulic oil, HLP(DIN51524) or HM(ISO6743/4).
If using synthetic fluids consult the factory for alternative seal materials.
- 4) Recommended minimum oil viscosity 13 mm²/s at 50°C.
- 5) Recommended maximum system operating temperature is 82°C.
- 6) To assure optimum motor life fill with fluid prior to loading and run at moderate load and speed for 10-15 minutes.

FUNCTION DIAGRAMS

MT 160

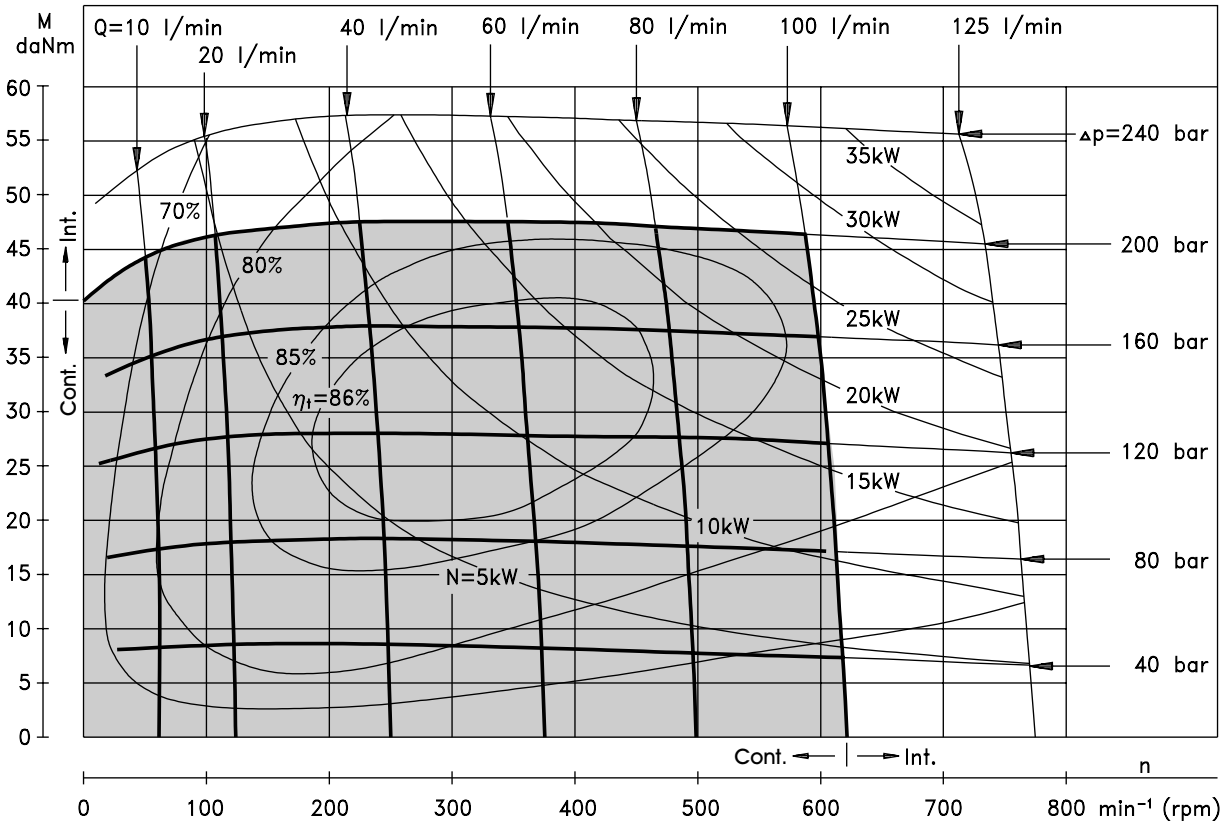

MT 200

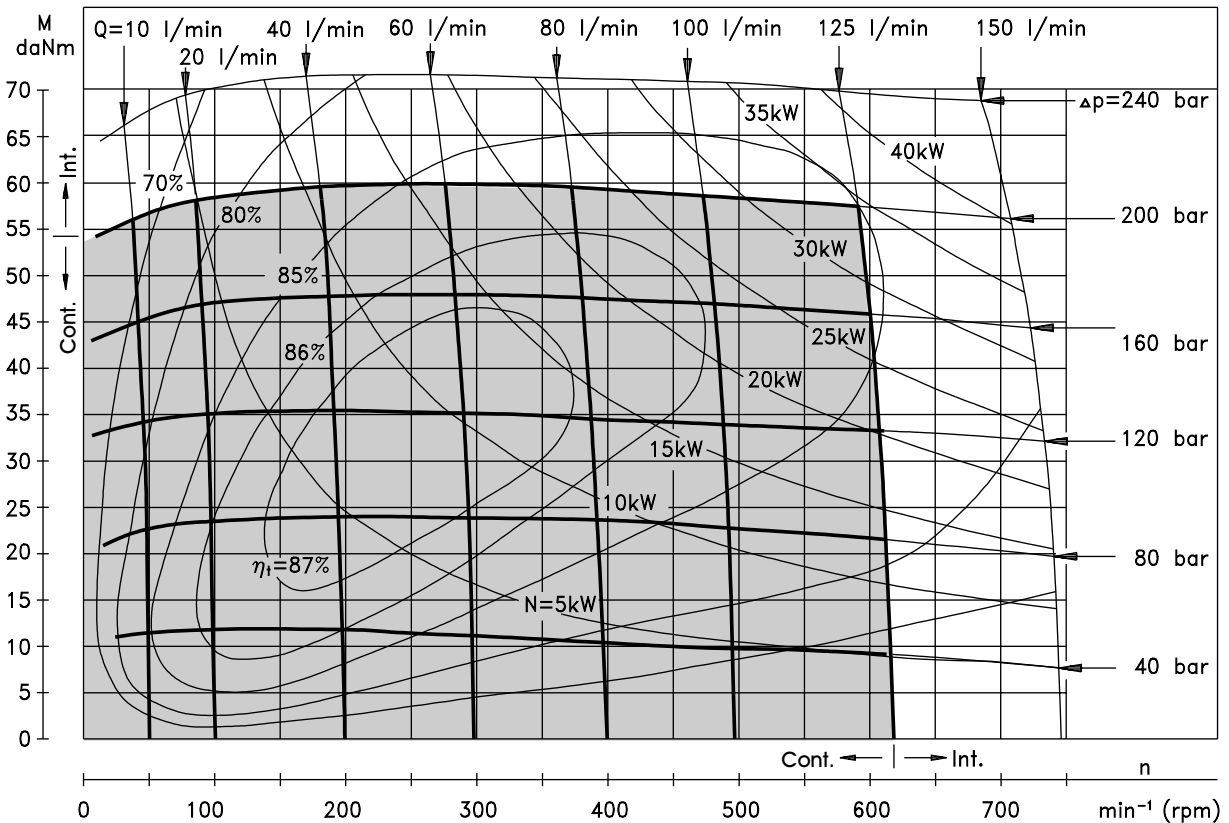

The function diagrams data was collected at back pressure 5÷10 bar and oil with viscosity of 32 mm²/s at 50° C.

FUNCTION DIAGRAMS

MT 250

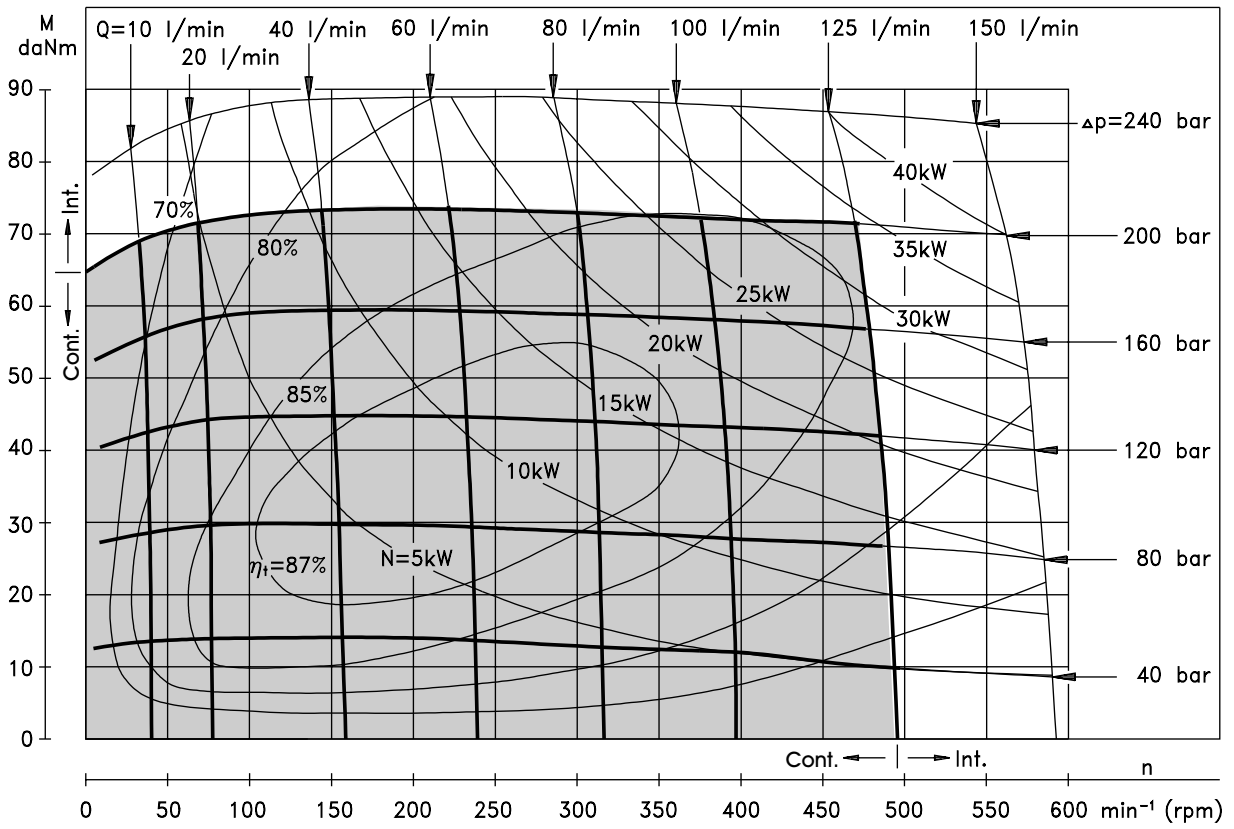

MT 315

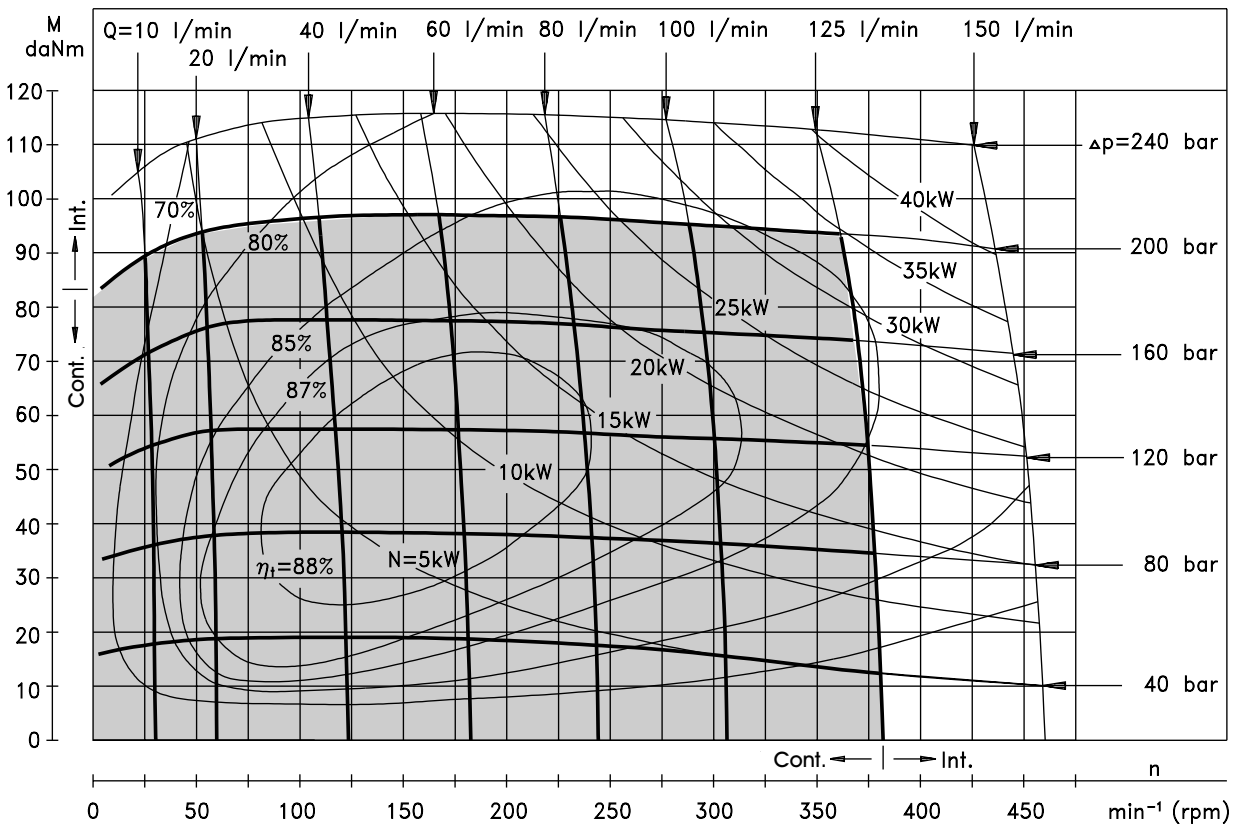

FUNCTION DIAGRAMS

MT 400

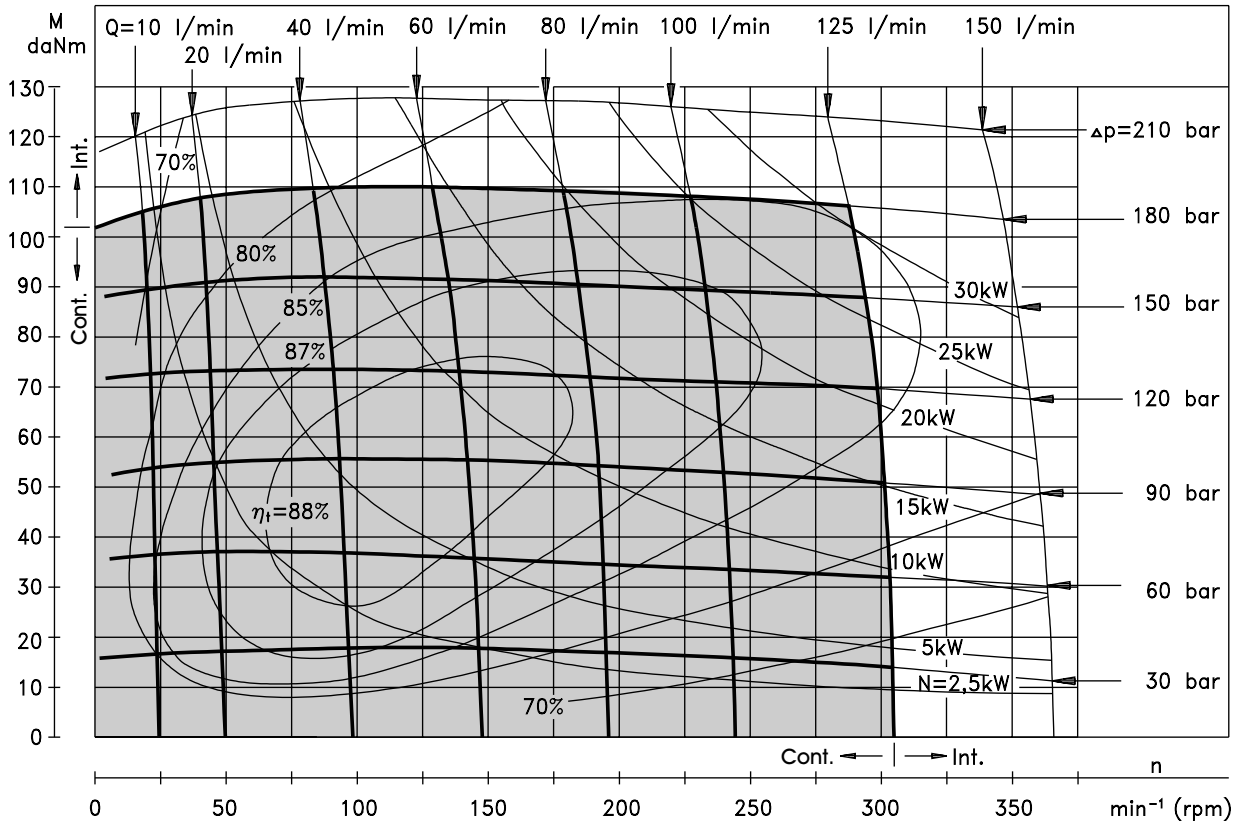

MT 500

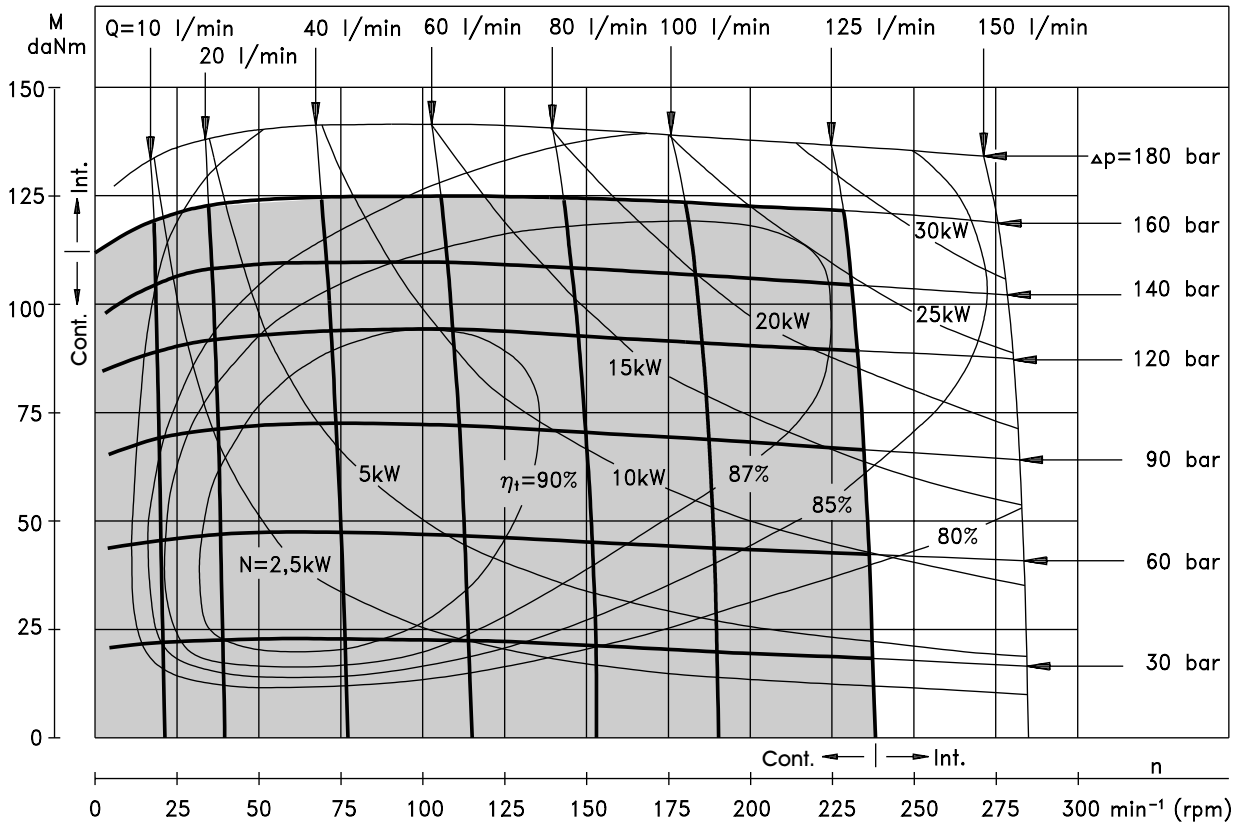

The function diagrams data was collected at back pressure 5 ÷ 10 bar and oil with viscosity of 32 mm²/s at 50° C.

FUNCTION DIAGRAMS

MT 630

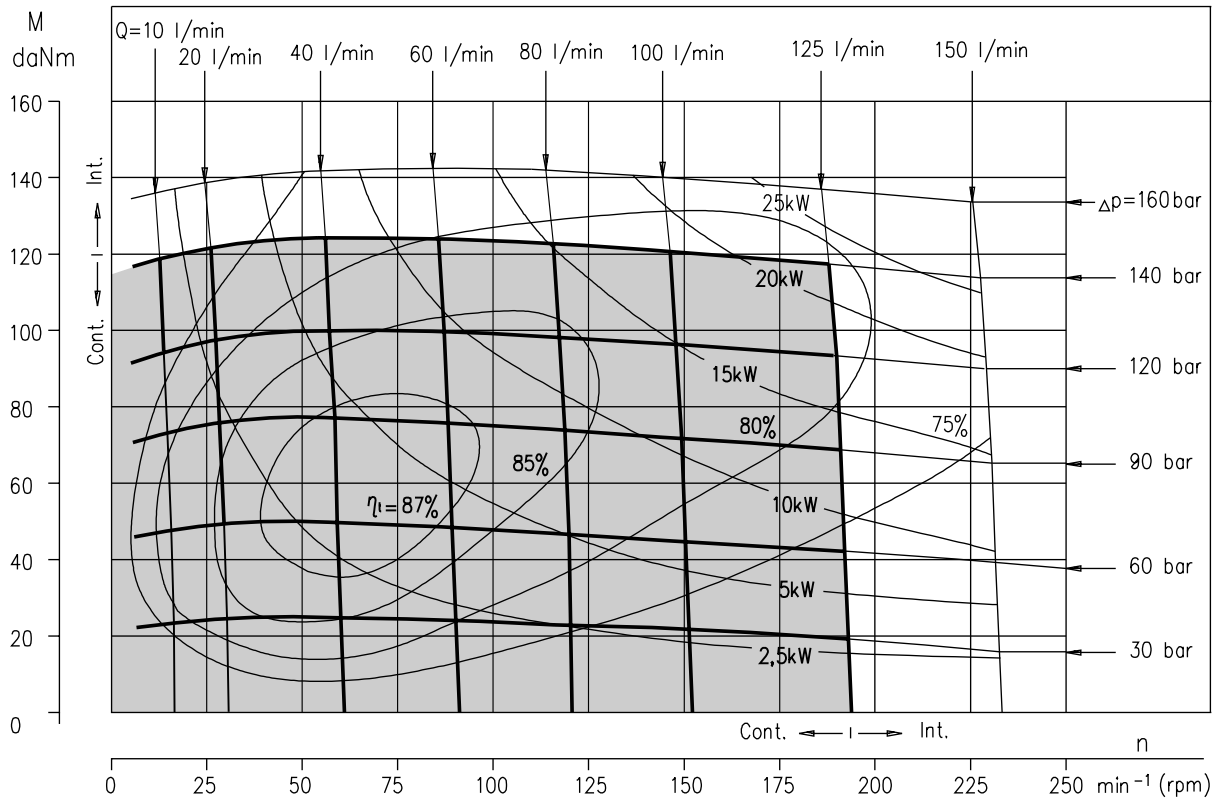

MT 725

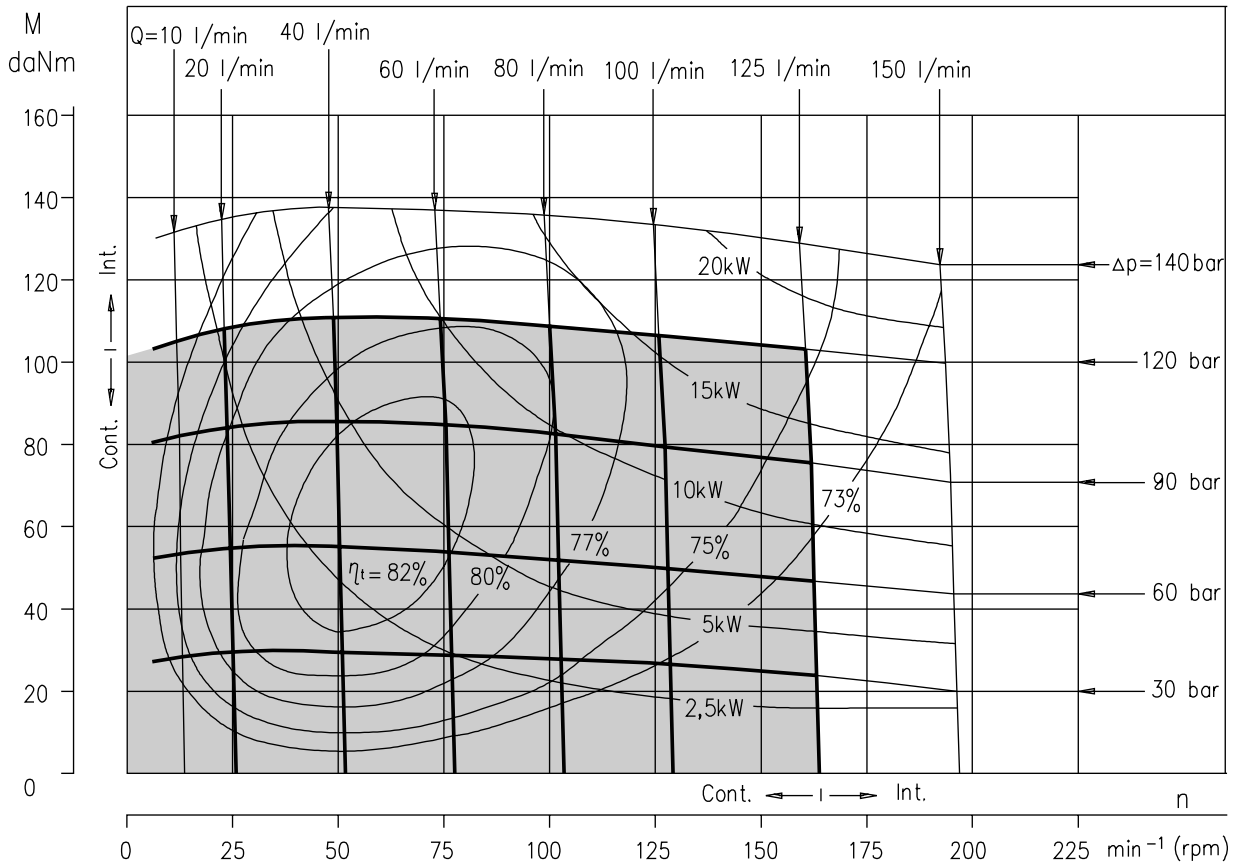

The function diagrams data was collected at back pressure 5 ÷ 10 bar and oil with viscosity of 32 mm²/s at 50° C.

DIMENSIONS AND MOUNTING DATA

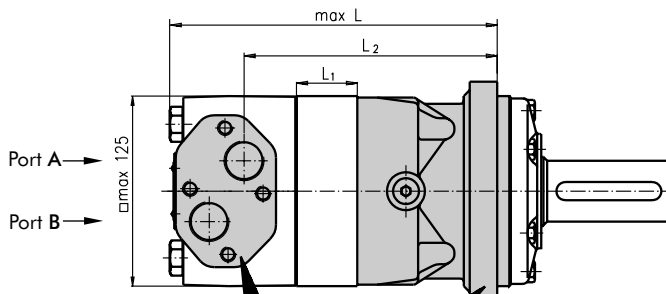

Porting

Side Ports

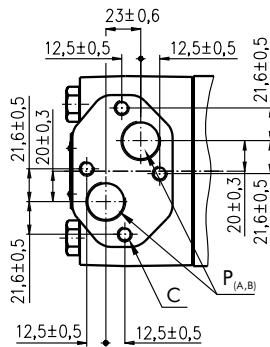

Mounting

Square Mount (4 Holes)

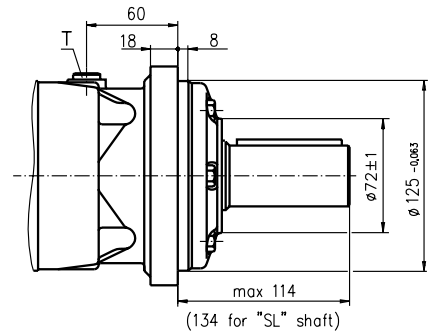
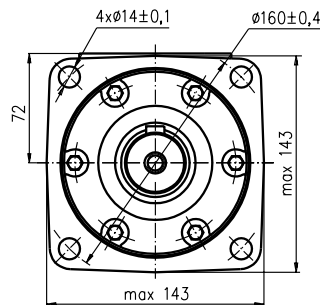

W Wheel Mount

E Rear Ports

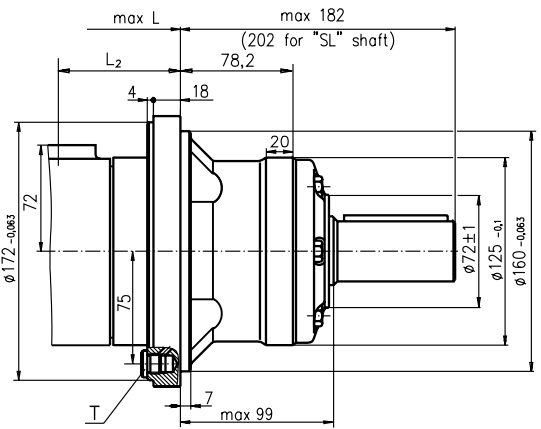
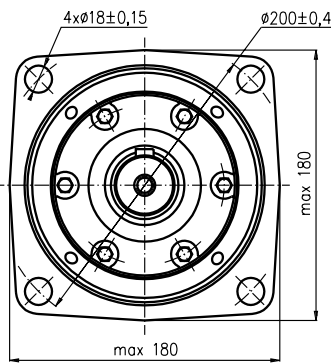
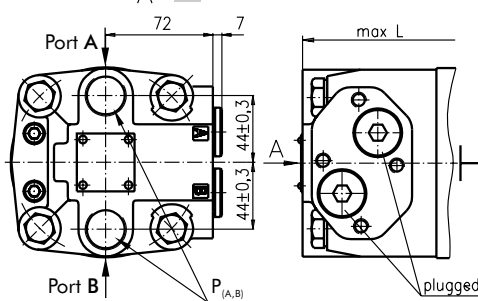

Standard Rotation

Viewed from Shaft End
 Port A Pressurized - CW
 Port B Pressurized - CCW

Reverse Rotation

Viewed from Shaft End
 Port A Pressurized - CCW
 Port B Pressurized - CW

C: 4xM10-10 mm depth

P_(A,B): 2xG3/4 or 2xM27x2-17 mm depth

T: G 1/4 or M14x1,5 - 12 mm depth (plugged)

Type	L, mm	Type	L, mm	L ₂ , mm	Type	L, mm	Type	L, mm	L ₂ , mm	*L ₁ , mm
MT 160	190	MTE 160	200	140	MTW 160	123	MTWE 160	133	73	16,5
MT 200	195	MTE 200	205	145	MTW 200	128	MTWE 200	138	78	21,5
MT 250	201	MTE 250	211	151	MTW 250	134	MTWE 250	144	84	27,8
MT 315	211	MTE 315	221	161	MTW 315	144	MTWE 315	154	94	37,0
MT 400	221	MTE 400	231	171	MTW 400	154	MTWE 400	164	104	47,5
MT 500	235	MTE 500	245	185	MTW 500	168	MTWE 500	178	118	61,5
MT 630	231	MTE 630	241	181	MTW 630	164	MTWE 630	174	114	57,5
MT 725	240	MTE 725	250	190	MTW 725	173	MTWE 725	183	123	66,5

* The width of the roll-gerotor is 3,5 mm greater than L₁.

SHAFT EXTENSIONS

C - $\varnothing 40$ straight, Parallel key A12x8x70 DIN 6885
Max. Torque 132,8 daNm

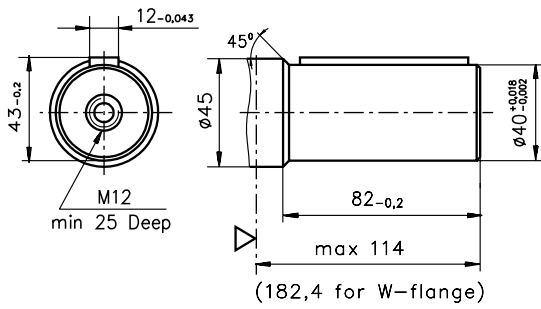

K -tapered 1:10, Parallel key B12x8x28 DIN 6885
Max. Torque 210,7 daNm

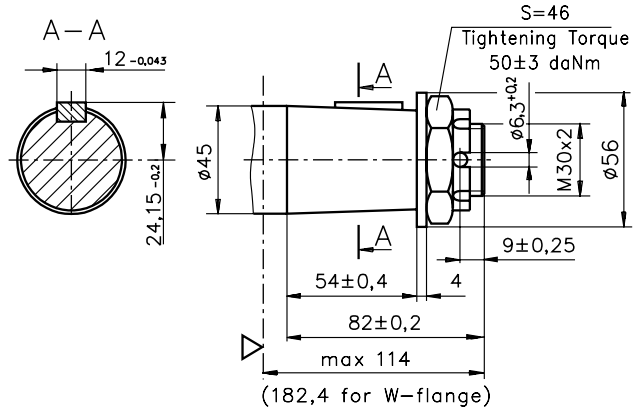

CO - $\varnothing 1\frac{1}{2}$ " straight, Parallel key $\frac{3}{8}$ "x $\frac{3}{8}$ "x $2\frac{1}{4}$ " BS46
Max. Torque 132,8 daNm

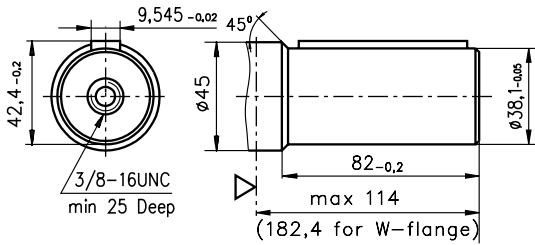

SH - $\varnothing 1\frac{1}{2}$ " splined 17T, DP 12/24 ANSI B92.1-1976
Max. Torque 132,8 daNm

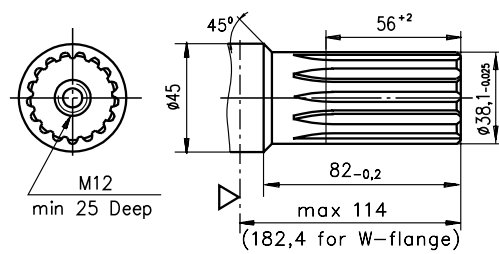

SL - $\varnothing 34,85$ p.t.o. DIN 9611 Form 1
Max. Torque 77 daNm

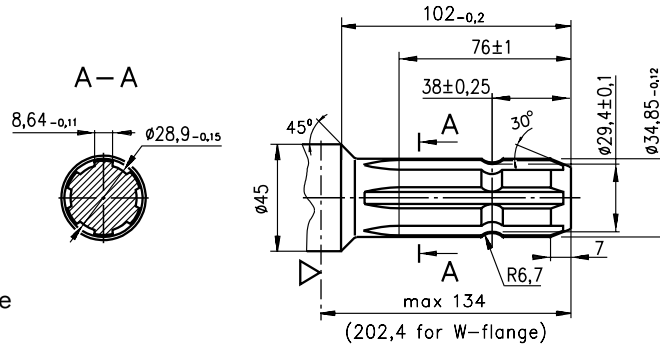

▽ - Motor Mounting Surface

MAX. PERMISSIBLE SHAFT SEAL PRESSURE for MT motors

**Max. return pressure without drain line or
max. pressure in the drain line**

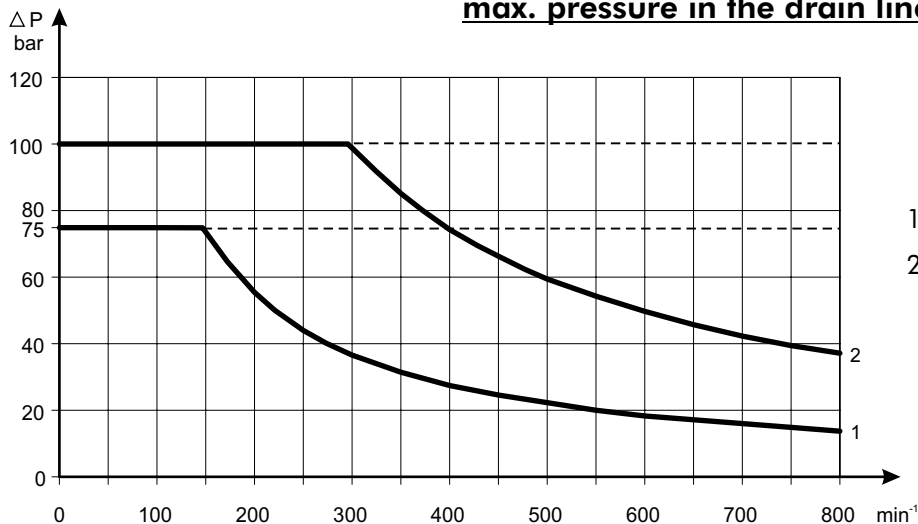

1: Drawing for Standard Shaft Seal
2: Drawing for High Pressure Seal ("U" Seal)

— - continuous operations
- - - - intermittent operations

DIMENSIONS AND MOUNTING DATA - MTS and MTV

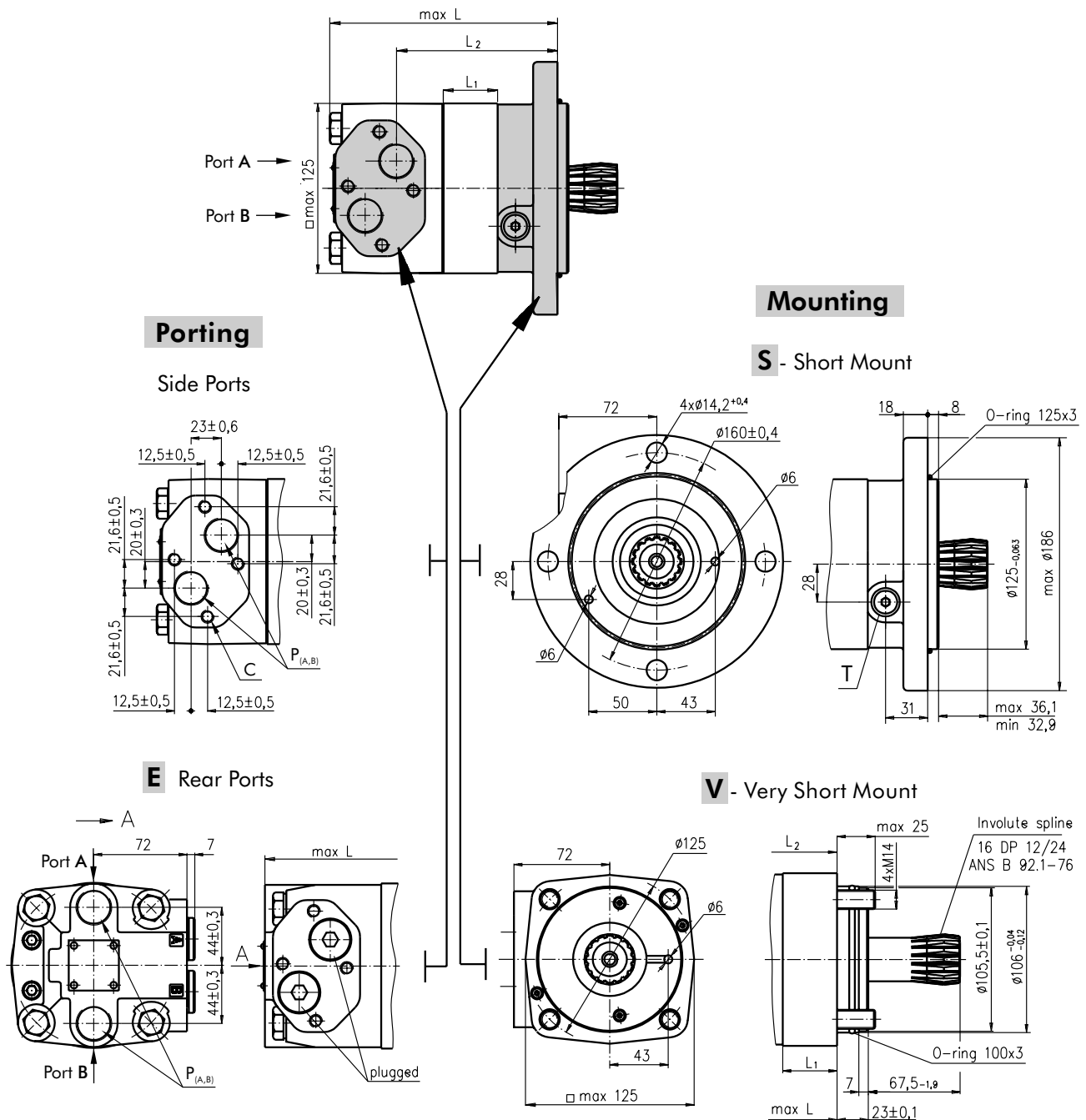

Standard Rotation
Viewed from Shaft End
Port A Pressurized - CW
Port B Pressurized - CCW

Reverse Rotation
Viewed from Shaft End
Port A Pressurized - CCW
Port B Pressurized - CW

C: 4xM10-10 mm depth
P_(A,B): 2xG3/4 or 2xM27x2-17 mm depth
T: G 1/4 or M14x1,5 - 12 mm depth (plugged)

Type	L, mm	Type	L, mm	L ₂ , mm	Type	L, mm	Type	L, mm	L ₂ , mm	*L ₁ , mm
MTS 160	146	MTSE 160	156	96	MTV 160	101	MTVE 160	111	51,5	16,5
MTS 200	151	MTSE 200	161	101	MTV 200	106	MTVE 200	116	56,5	21,5
MTS 250	157	MTSE 250	167	107	MTV 250	112	MTVE 250	122	62,8	27,8
MTS 315	166	MTSE 315	176	116	MTV 315	121	MTVE 315	131	72	37,0
MTS 400	177	MTSE 400	187	127	MTV 400	132	MTVE 400	142	82,5	47,5
MTS 500	191	MTSE 500	201	142	MTV 500	146	MTVE 500	156	96,5	61,5
MTS 630	187	MTSE 630	197	138	MTV 630	142	MTVE 630	152	92,5	57,5
MTS 725	196	MTSE 725	206	147	MTV 725	151	MTVE 725	161	101,5	66,5

* The width of the roll-gerotor is 3,5 mm greater than L₁.

DIMENSIONS OF THE ATTACHED COMPONENT

MTS

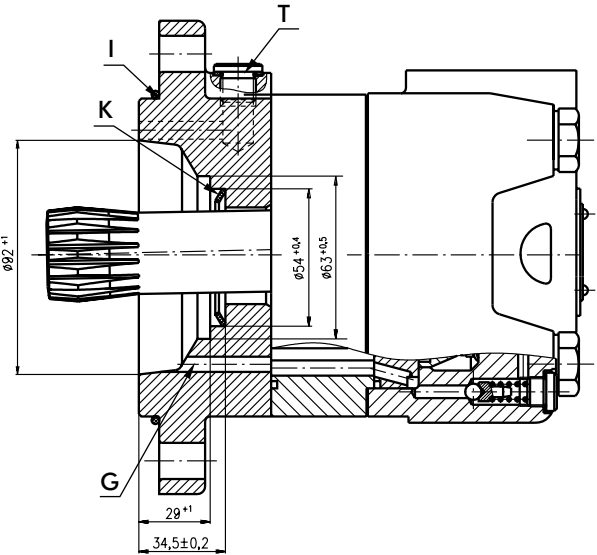
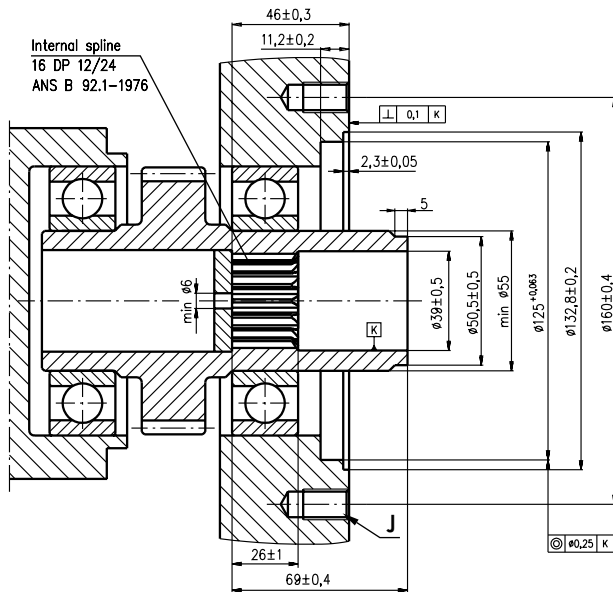

- F:** Oil circulation hole
- G:** Internal drain channel
- H:** Hardened stop plate

- I:** O- Ring 125x3mm
- J:** 4xM12-18 mm depth, 90°
- K:** Conical seal ring
- T:** Drain connection G1/4 or M14x1,5

MTV

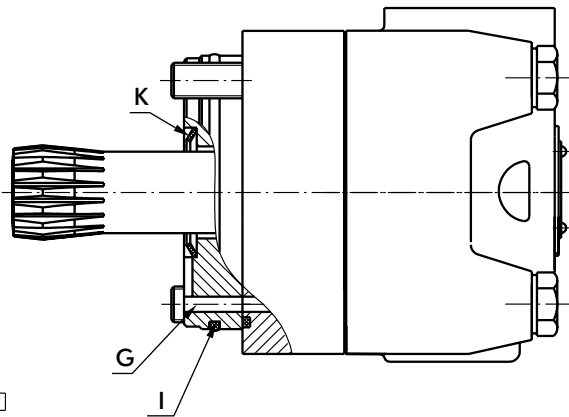
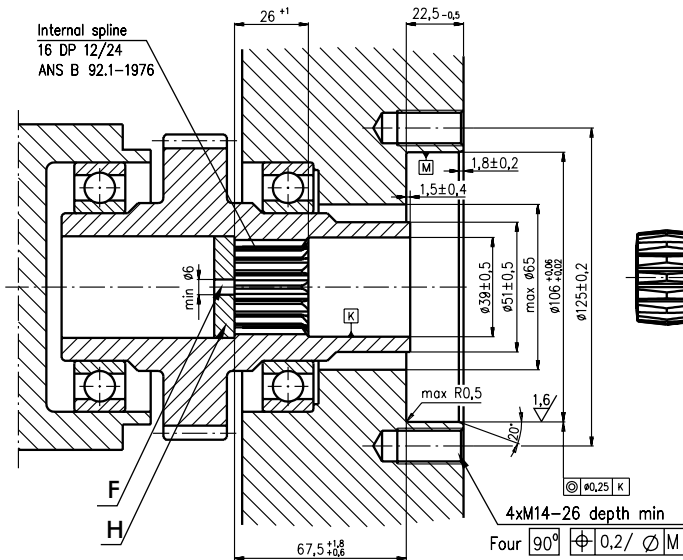

- F:** Oil circulation hole
- G:** Internal drain channel

- H:** Hardened stop plate
- I:** O- Ring 100x3mm
- K:** Conical seal ring

DRAIN CONNECTION

A drain line ought to be used when pressure in the return line can exceed the permissible pressure. It can be connected:

- For MTS at the drain port of the motor;
- For MTV at the drain connection of the attached component. The maximum pressure in the drain line is limited by the attached component and its shaft seal.

The drain line must be possible for oil to flow freely between motor and attached component and must be led to the tank. The maximum pressure in the drain line is limited by the attached component and its seal.

INTERNAL SPLINE DATA FOR THE ATTACHED COMPONENT

Standard ANS B92.1-1976, class 5
[$m=2.1166$; corrected $x.m=+1,0$]

Fillet Root Side Fit		mm
Number of Teeth	z	16
Diametral Pitch	DP	12/24
Pressure Angle		30°
Pitch Dia.	D	33,8656
Major Dia.	D _{ri}	38,4 ^{+0,4}
Minor Dia.	D _i	32,15 ^{+0,04}
Space Width [Circular]	Lo	4,516±0,037
Fillet Radius	R	0,5
Max. Measurement between Pin	L	26,9 ^{+0,10}
Pin Dia.	d	4,835±0,001

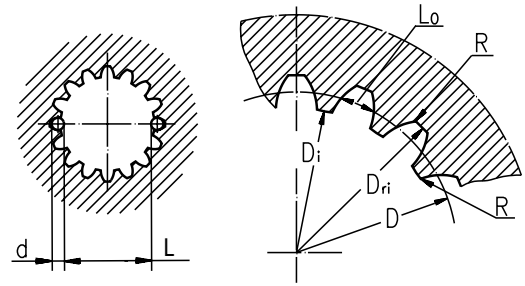

Hardening Specification:
 HV=750±50 on the surface
 HV=560 at 0,7±0,2 mm case depth
 Material 20 MoCr4 EN 10084 or better

PERMISSIBLE SHAFT LOADS

The output shaft runs in tapered bearings that permit high axial and radial forces. Curve "1" shows max. radial shaft load. Any shaft load exceeding the values quoted in the curve will seriously reduce motor life. The two other curves apply to a B10 bearing life of 3000 hours at 200 RPM.

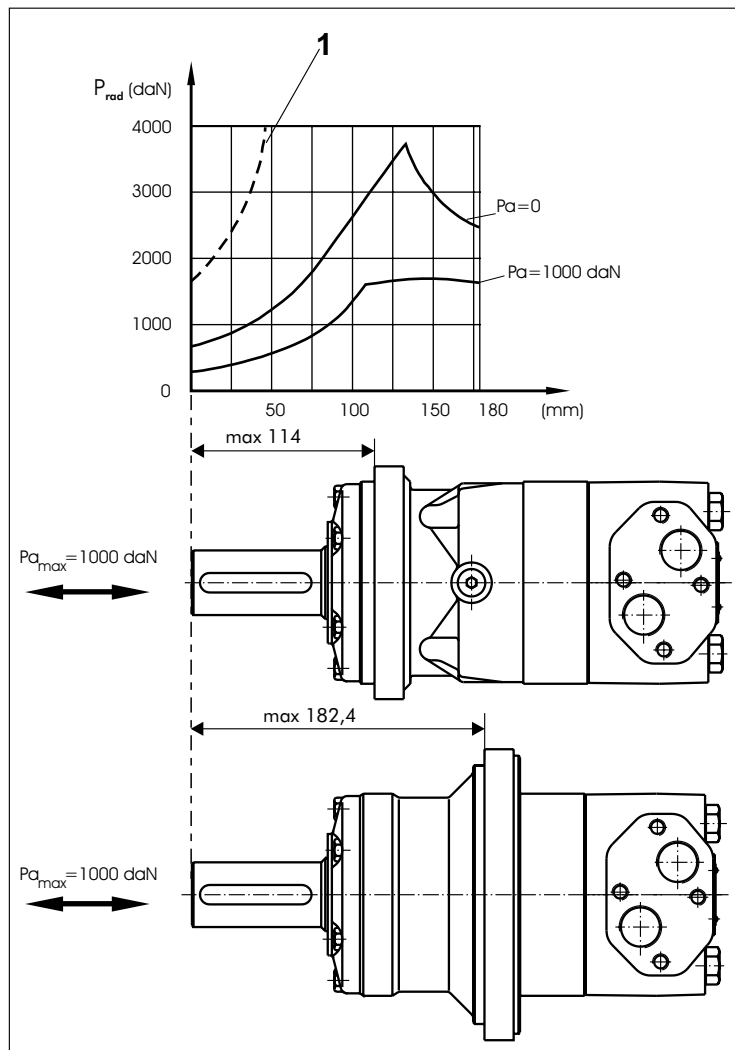

MOTORS WITH TACHO CONNECTION

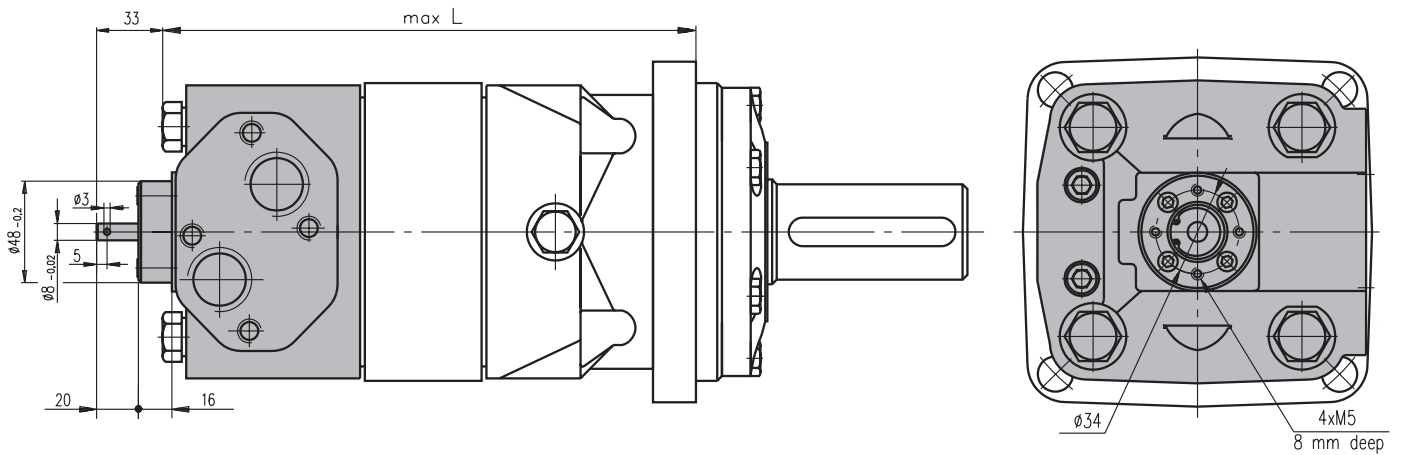

ORDER CODE

	1	2	3	4	5	6	7	8
MT								

Pos.1 - Mounting Flange

omit - Square mount, four holes

S - Short mount

V - Veryshort mount

W - Wheel mount

Pos.2 - Port type

omit - Side ports

E - Rear ports

Pos.3 - Displacement code

160 - 161,1 [cm³/rev]

200 - 201,4 [cm³/rev]

250 - 251,8 [cm³/rev]

315 - 326,3 [cm³/rev]

400 - 410,9 [cm³/rev]

500 - 523,6 [cm³/rev]

630 - 631,2 [cm³/rev]

725 - 724,3 [cm³/rev]

Pos.4 - Shaft Extensions*

omit - for **S** and **V** mounting flange

C - $\varnothing 40$ straight, Parallel key A12x8x70 DIN6885

CO - $\varnothing 1\frac{1}{2}$ " straight, Parallel key $\frac{3}{8}$ "x $\frac{3}{8}$ "x $2\frac{1}{4}$ " BS46

K - $\varnothing 45$ tapered 1:10, Parallel key B12x8x28 DIN6885

SL - $\varnothing 34,85$ p.t.o. DIN 9611 Form 1

SH - $\varnothing 1\frac{1}{2}$ " splined 17T ANS B92.1-1976

Pos.5 - Shaft Seal Version (see page 38)

omit - Low pressure seal

U - High pressure seal

Pos.6 - Ports

omit - BSPP (ISO 228)

M - Metric (ISO 262)

Pos.7 - Special Features (see page 65)

Pos.8 - Design Series

omit - Factory specified

NOTES:

* The permissible output torque for shafts must not be exceeded!

The hydraulic motors are mangano-phosphatized as standard.

HYDRAULIC MOTORS MTM



APPLICATION

- » Skid Steer Loaders
- » Metal working machines
- » Trenchers
- » Augers
- » Machines for agriculture
- » Road building machines
- » Special vehicles
- » Mine machines
- » Woodworking and sawmill machinery
- » Conveyors etc.

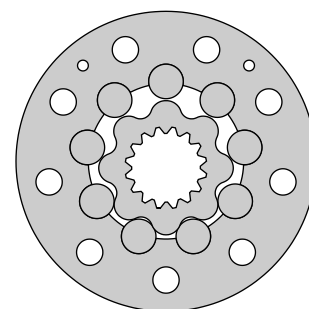

CONTENTS

Specification data	44
Function diagrams	45÷47
Dimensions and mounting	48÷50
Shaft extensions	51
Permissible shaft loads	51
Dimensions and mounting- MTMV	52
Dimensions and mounting- MTM6V	53
Internal Spline data	54
Order code	54

OPTIONS

- » Model- Disc valve, roll-gerotor
- » Flange with wheel mount
- » Short motor
- » Side ports
- » Shafts- straight, splined and tapered
- » BSPP ports;
- » Other special features.

EXCELLENCE

- » High torque and pressure drop
- » High inlet pressure
- » High starting torque
- » Improved efficiency at high pressure drop
- » Smooth operation at low speed

GENERAL

Displacement, [cm ³ /rev.]	201,4÷724,3
Max. Speed, [RPM]	625÷170
Max. Torque, [daNm]	72÷175
Max. Output, [kW]	28÷41
Max. Pressure Drop, [bar]	250÷160
Max. Oil Flow, [l/min]	125
Min. Speed, [RPM]	5
Permissible Shaft Loads, [daN]	P _a =1000
Pressure fluid	Mineral based- HLP(DIN 51524) or HM(ISO 6743/4)
Temperature range, [°C]	-30÷90
Optimal Viscosity range, [mm ² /s]	20÷75
Filtration	ISO code 20/16 (Min. recommended fluid filtration of 25 micron)

Oil flow in drain line

Pressure drop (bar)	Viscosity (mm ² /s)	Oil flow in drain line (l/min)
140	20	2,5
	35	1,5
210	20	5
	35	3

Pressure Losses

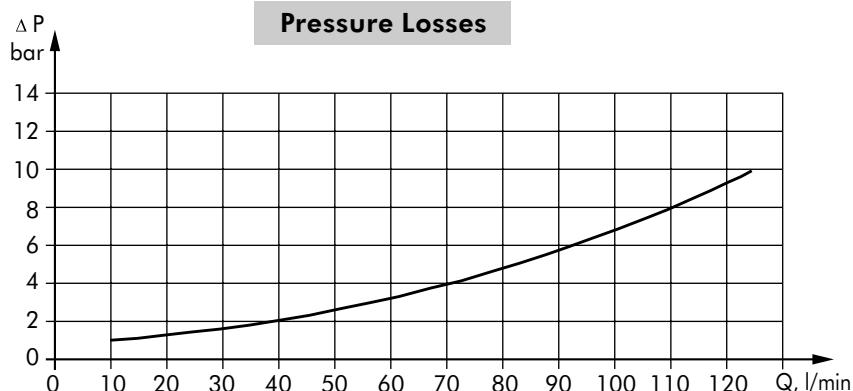

SPECIFICATION DATA

Type	MTM 200	MTM 250	MTM 315	MTM 400	MTM 470	MTM 500	MTM 630	MTM 725	
Displacement [cm ³ /rev.]	201,4	251,8	326,3	410,9	475	523,6	631,2	724	
Max. Speed, [RPM]	cont.	625	500	380	305	260	240	185	170
	Int.*	750	600	460	365	315	285	225	215
Max. Torque [daNm]	cont.	72	90	116	147	171	172	175	160
	Int.*	102	128	163	206	215	215	215	192
	peak**	115	144	186	235	240	240	250	240
Max. Output [kW]	cont.	41	41	41	41	41	37,5	28	26
	int.*	65	70	70	75	55	51	42	40
Max. Pressure Drop [bar]	cont.	250	250	250	250	250	230	185	160
	Int.*	350	350	350	350	315	280	225	210
	peak**	400	400	400	400	350	320	270	260
Max. Oil Flow [l/min]	cont.	125	125	125	125	125	125	125	125
	Int.*	150	150	150	150	150	150	150	150
Max. Inlet Pressure [bar]	cont.	270	270	270	270	270	270	270	270
	Int.*	370	370	370	370	370	370	370	370
	peak**	420	420	420	420	420	420	420	420
Max. Return Pressure without Drain Line or Max. Pressure in Drain Line , [bar]	cont. 0-100 RPM	75	75	75	75	75	75	75	75
	cont. 100-300 RPM	40	40	40	40	40	40	40	40
Max. Return Pressure with Drain Line [bar]	cont. >300 RPM	20	20	20	20	20	-	-	-
	Int.* 0-max. RPM	75	75	75	75	75	75	75	75
Max. Starting Pressure with Unloaded Shaft, [bar]	cont.	270	270	270	270	270	270	270	270
	Int.*	370	370	370	370	370	370	370	370
	Peak**	420	420	420	420	420	420	420	420
Min. Starting Torque [daNm]	6	6	6	6	6	6	6	6	
Min. Speed***, [RPM]	60	75	97	122	142	143	145	148	
Weight, [kg]	MTM	5	5	5	5	5	5	5	5
	MTMW	26,9	27,3	28,1	29	29,7	30,2	29,7	31
	MTMV	27,4	27,8	28,6	29,5	30,2	30,7	30,2	31,5
	MTMV	15,7	16,1	16,9	17,8	18,5	19	18,5	19,8

* Intermittent operation: the permissible values may occur for max. 10% of every minute.

** Peak load: the permissible values may occur for max. 1% of every minute.

*** For speeds of 5 RPM lower than given, consult factory or your regional manager.

- 1) Intermittent speed and intermittent pressure must not occur simultaneously.
- 2) Recommended filtration is per ISO cleanliness code 20/16. A nominal filtration of 25 micron or better.
- 3) Recommend using a premium quality, anti-wear type mineral based hydraulic oil, HLP(DIN51524) or HM(ISO6743/4).
If using synthetic fluids consult the factory for alternative seal materials.
- 4) Recommended minimum oil viscosity 13 mm²/s at 50°C.
- 5) Recommended maximum system operating temperature is 82°C.
- 6) To assure optimum motor life fill with fluid prior to loading and run at moderate load and speed for 10-15 minutes.

FUNCTION DIAGRAMS

MTM 250

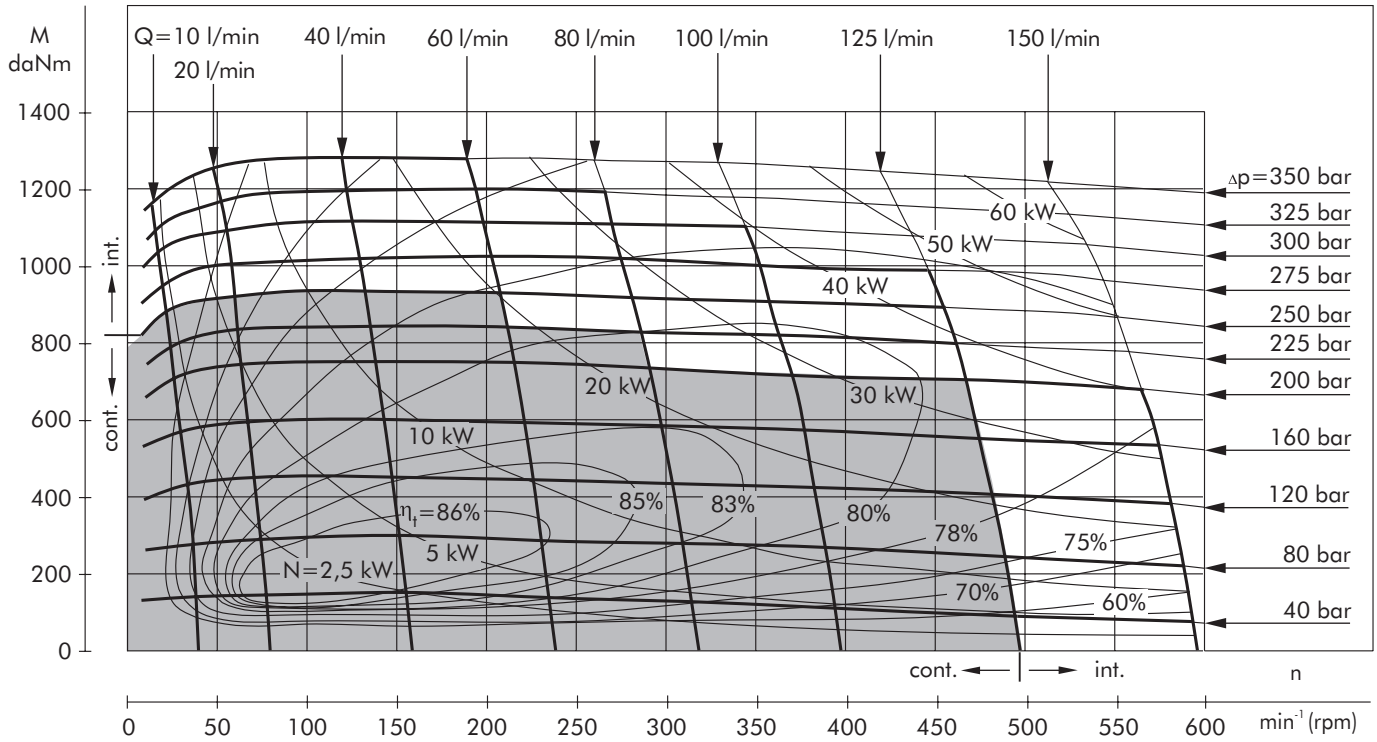

MTM 315

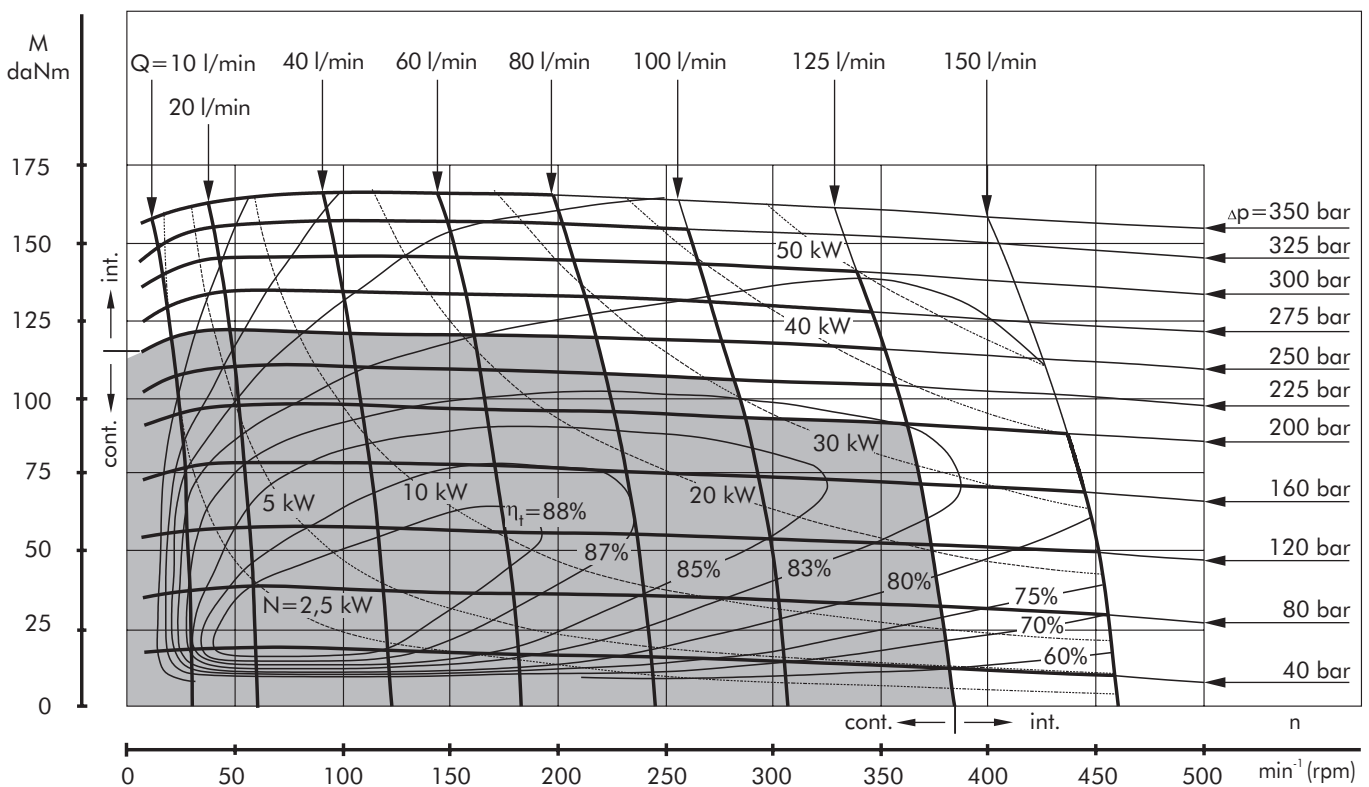

The function diagrams data was collected at back pressure 5 ÷ 10 bar and oil with viscosity of 32 mm²/s at 50° C.

FUNCTION DIAGRAMS

MTM 400

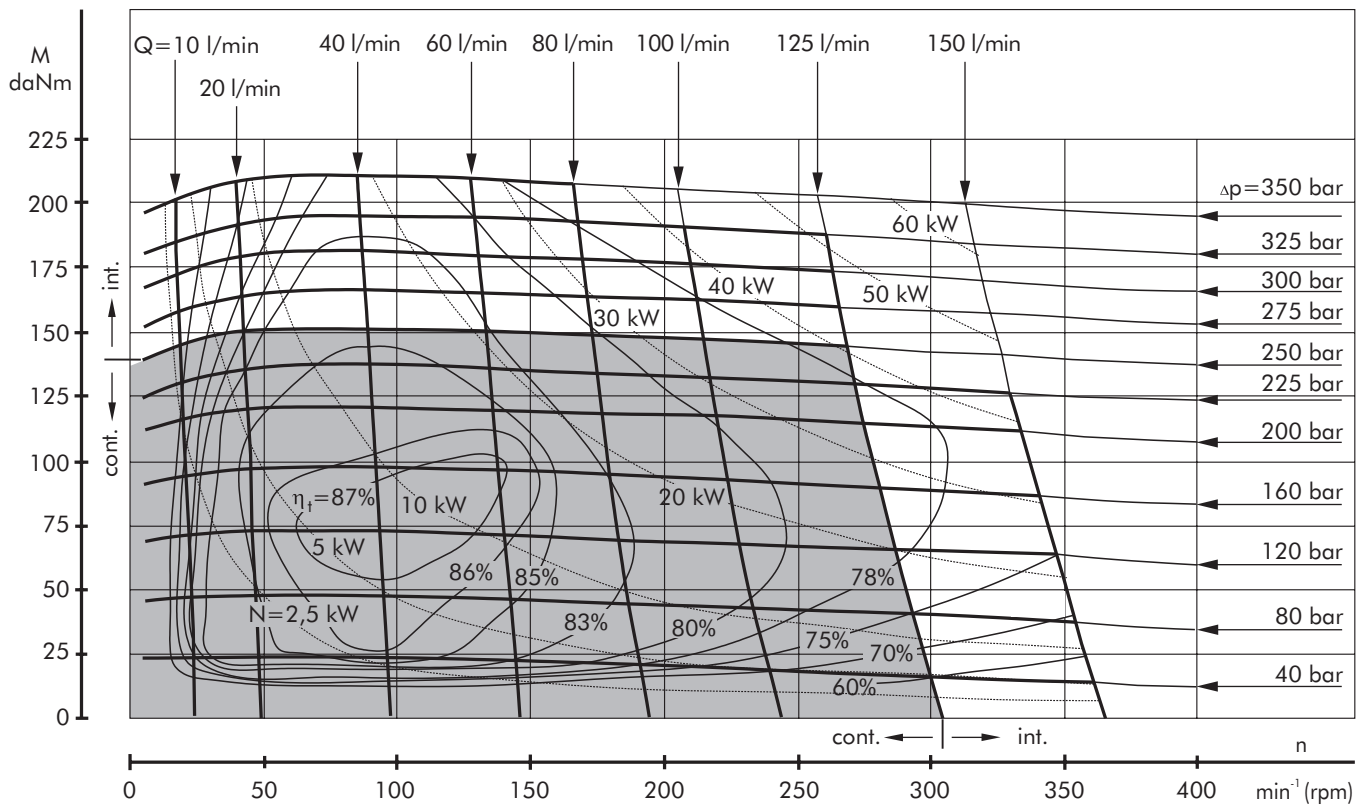

MTM 470

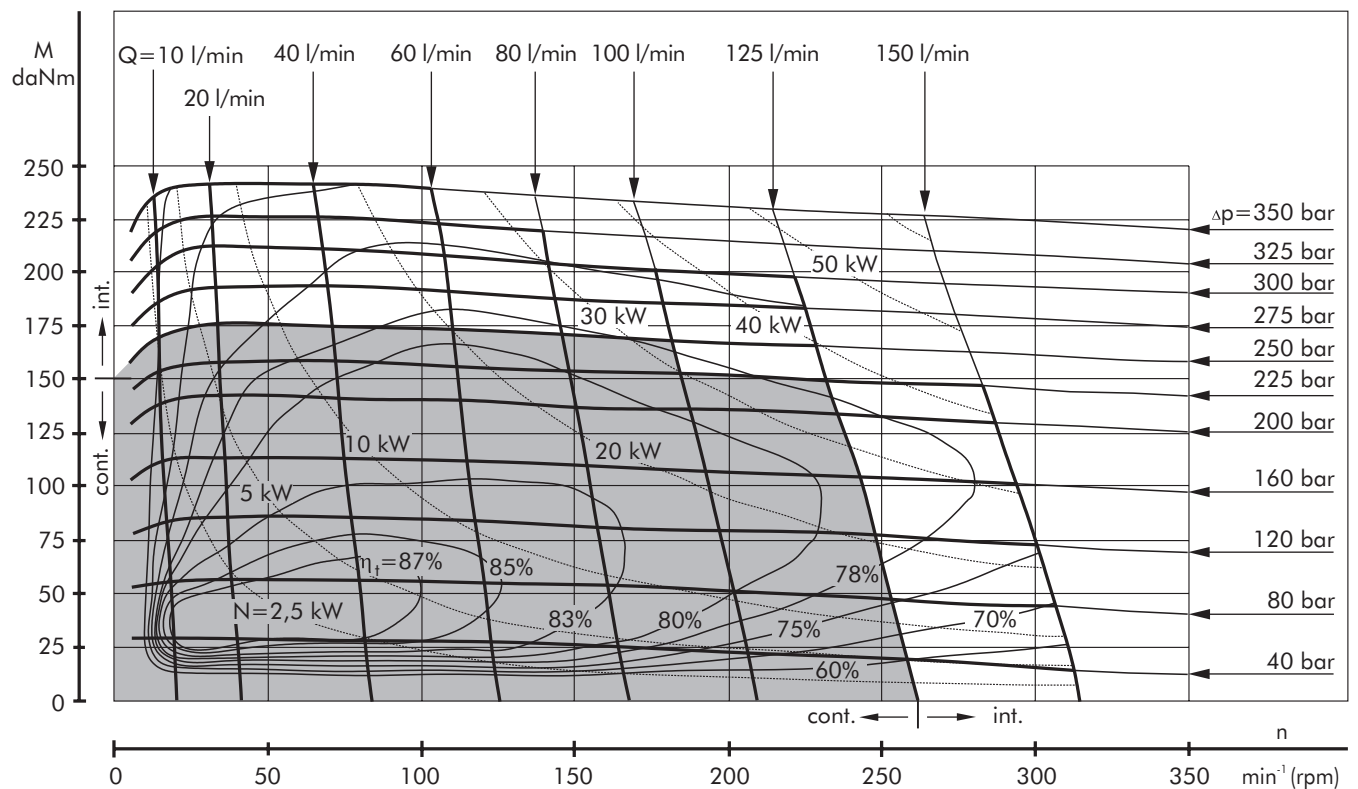

The function diagrams data was collected at back pressure 5 ÷ 10 bar and oil with viscosity of 32 mm²/s at 50° C.

FUNCTION DIAGRAMS

MTM 500

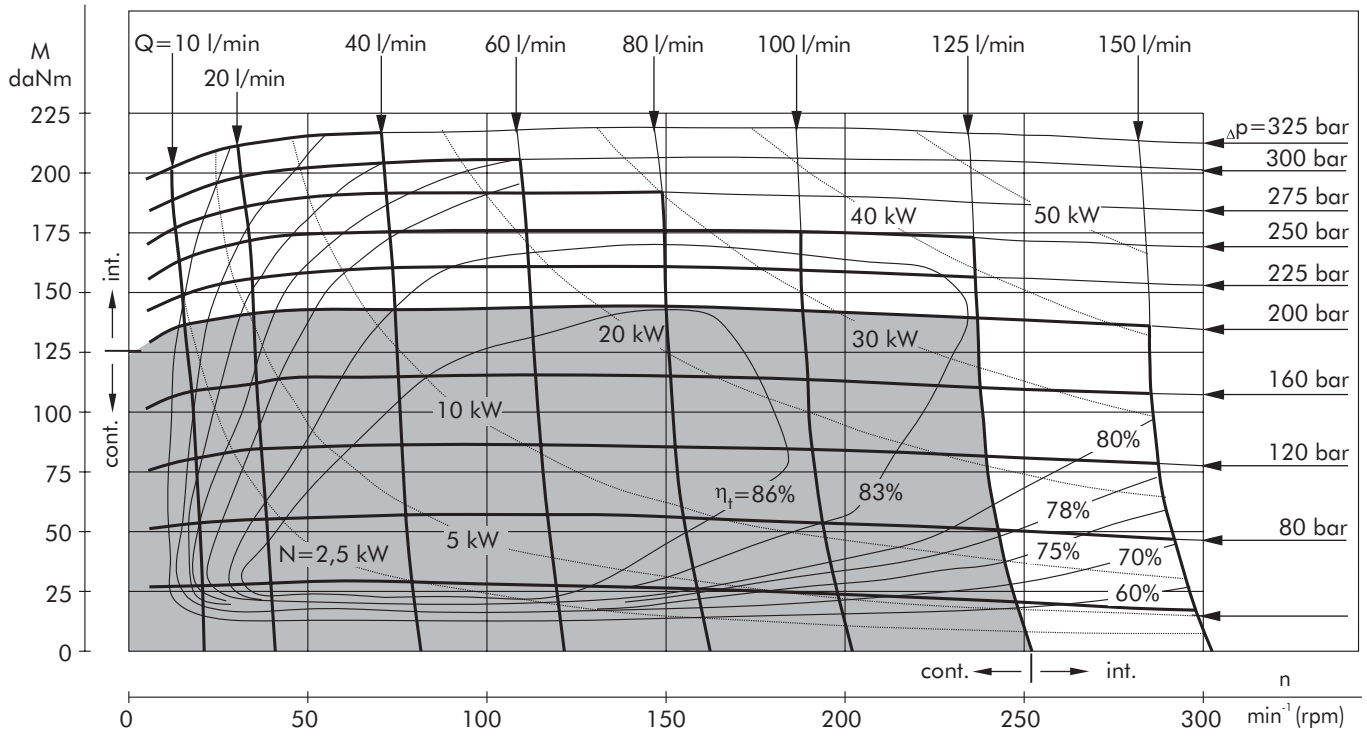

MTM 630

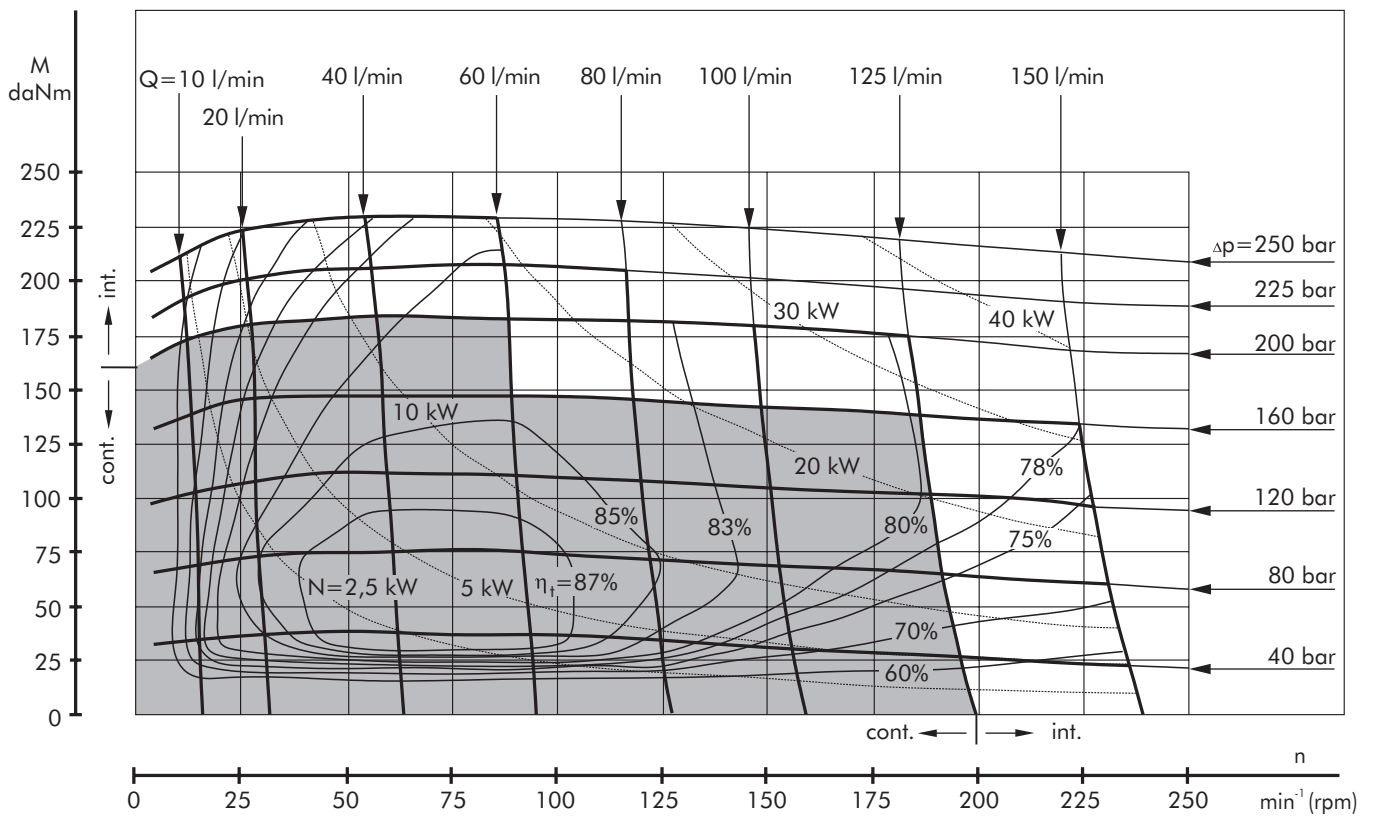

The function diagrams data was collected at back pressure 5 ÷ 10 bar and oil with viscosity of 32 mm²/s at 50° C.

DIMENSIONS - MTM and MTMC

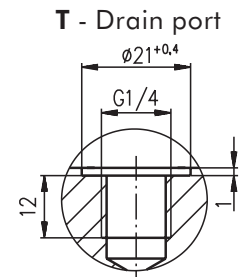
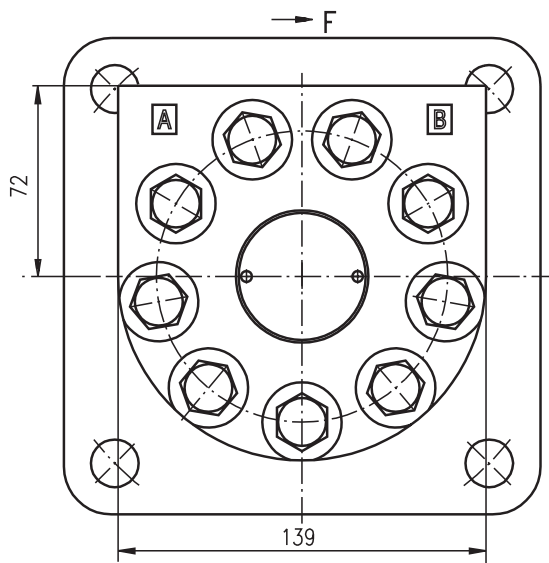
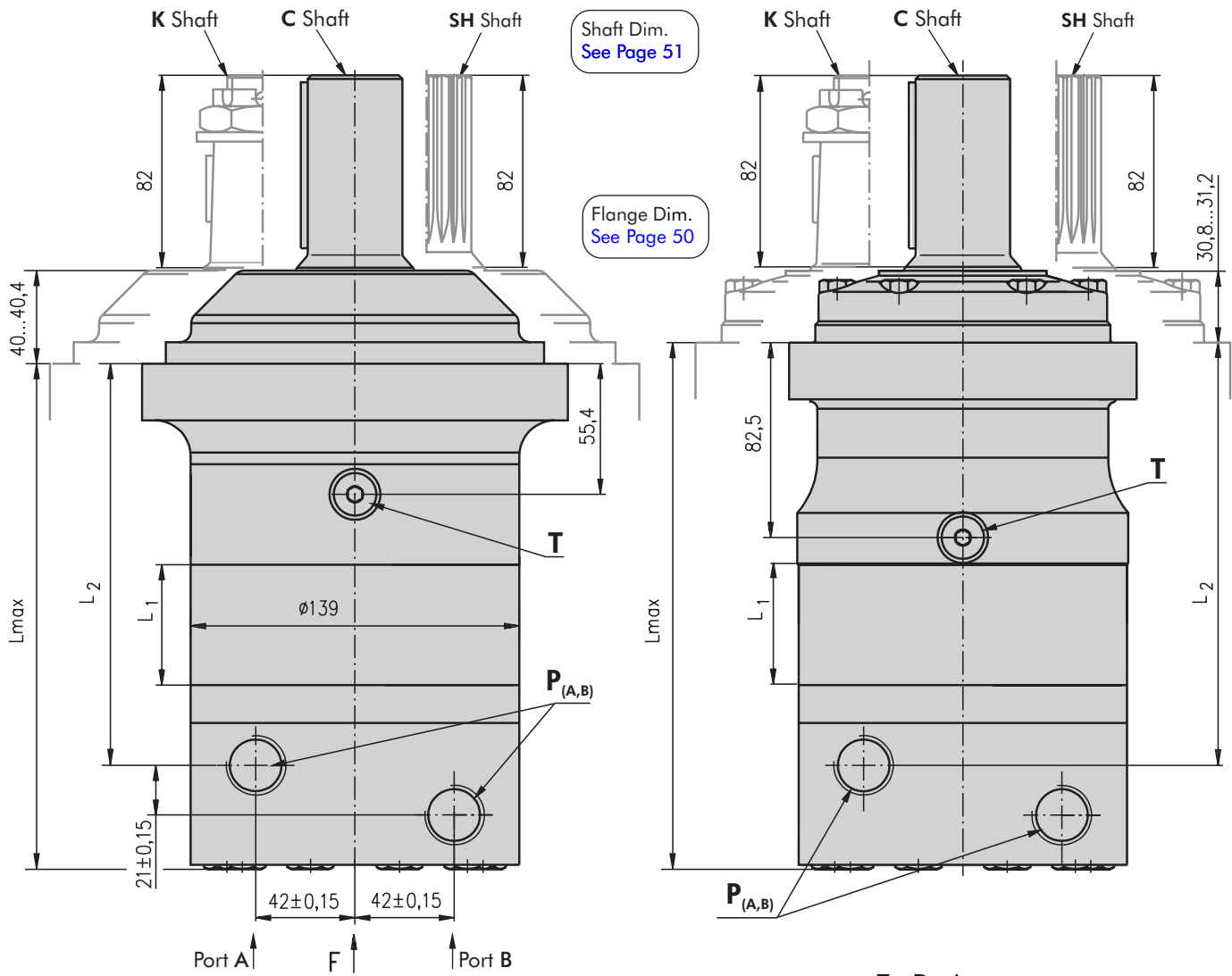

P_(A,B) : 2xG3/4 - 17 mm depth
T : G1/4 - 12 mm depth (plugged)

Standard Rotation Viewed from Shaft End Port A Pressurized - CW Port B Pressurized - CCW	Reverse Rotation Viewed from Shaft End Port A Pressurized - CCW Port B Pressurized - CW
--	---

Type	L, mm	L ₂ , mm	Type	L, mm	L ₂ , mm	L ₁ , mm
MTM 200	188	142,3	MTMC 200	198	153	25
MTM 250	194	148,6	MTMC 250	204,5	159,3	31,3
MTM 315	203	157,8	MTMC 315	213,5	168,5	40,5
MTM 400	214	168,3	MTMC 400	224	179	51
MTM 470	222	176,3	MTMC 470	232	187	59
MTM 500	228	182,3	MTMC 500	238	193	65
MTM 630	224	178,3	MTMC 630	234	189	61
MTM 725	233	187,3	MTMC 725	243	198	70

DIMENSIONS - MTMW

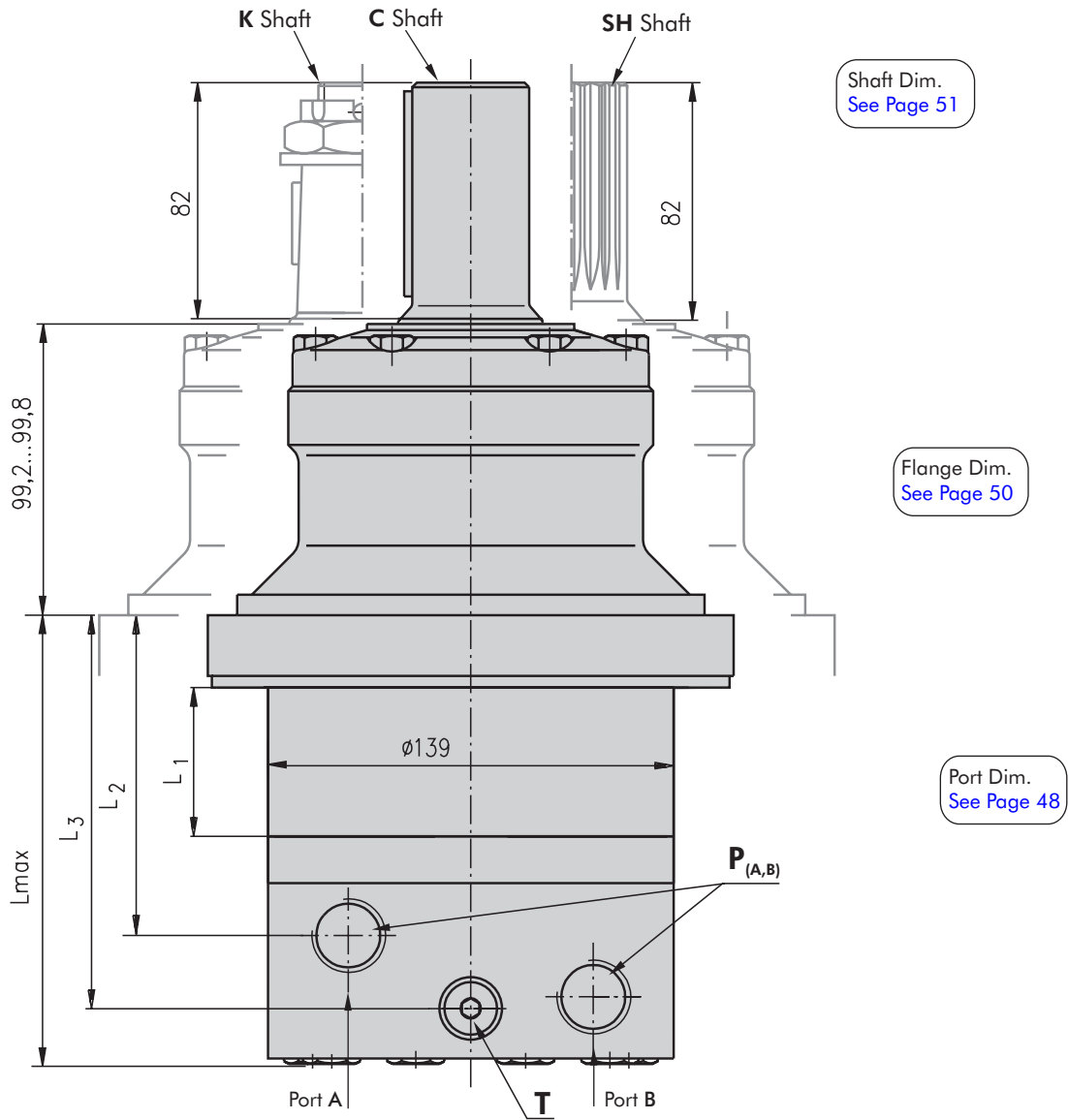

Standard Rotation
Viewed from Shaft End
Port A Pressurized - CW
Port B Pressurized - CCW

Reverse Rotation
Viewed from Shaft End
Port A Pressurized - CCW
Port B Pressurized - CW

P_(A,B): 2xG3/4 - 17 mm depth
T : G1/4 - 12 mm depth (plugged)

Type	L, mm	L1, mm	L2, mm	L3, mm
MTMW 200	129	25	83,8	111,1
MTMW 250	135	31,3	90,1	117,4
MTMW 315	144	40,5	99,3	126,6
MTMW 400	155	51	109,8	137,1
MTMW 470	163	59	117,8	145,1
MTMW 500	169	65	123,8	151,1
MTMW 630	165	61	119,8	147,1
MTMW 725	174	70	128,8	156,1

DIMENSIONS OF MOUNTING

4-Bolt flange
spigot diameter $\varnothing 160$ mm - BC $\varnothing 200$ mm

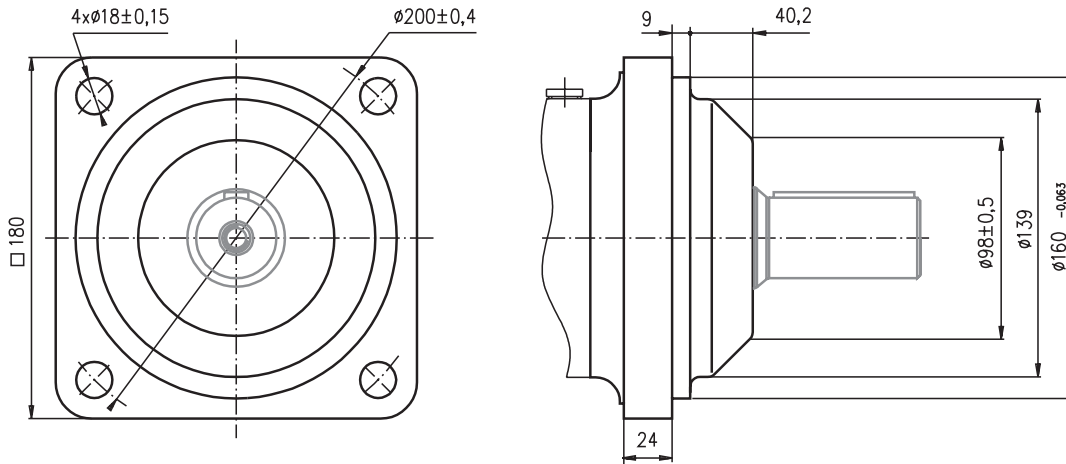

C 4-Bolt flange
spigot diameter $\varnothing 125$ mm - BC $\varnothing 160$ mm

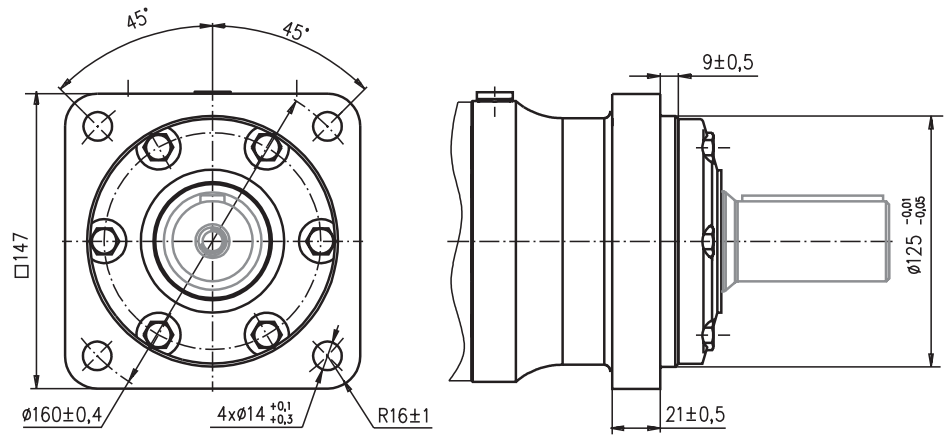

W 4-Bolt flange, Wheel Motor
spigot diameter $\varnothing 160$ mm - BC $\varnothing 200$ mm

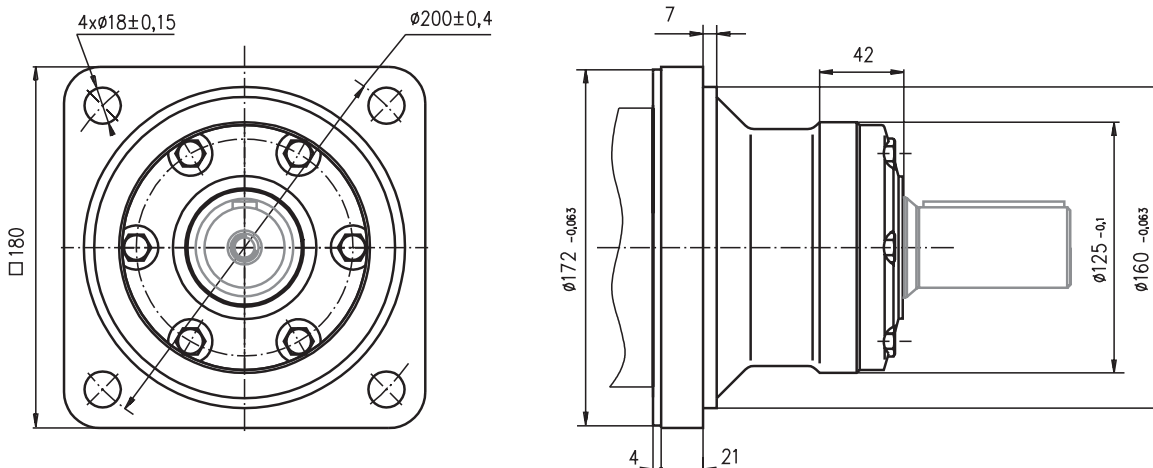

SHAFT EXTENSIONS

C - ϕ 40 straight, Parallel key A12x8x70 DIN 6885
Max. Torque 132,8 daNm

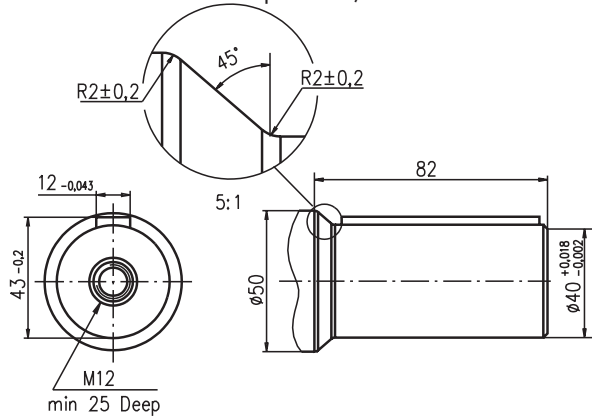

SH - ϕ 1½" splined 17T, DP 12/24 ANSI B92.1-1976
Max. Torque 132,8 daNm

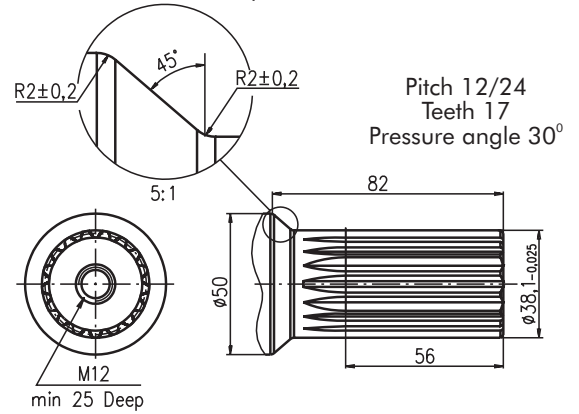

K -tapered 1:10, Parallel key B12x8x28 DIN 6885
Max. Torque 210,7 daNm

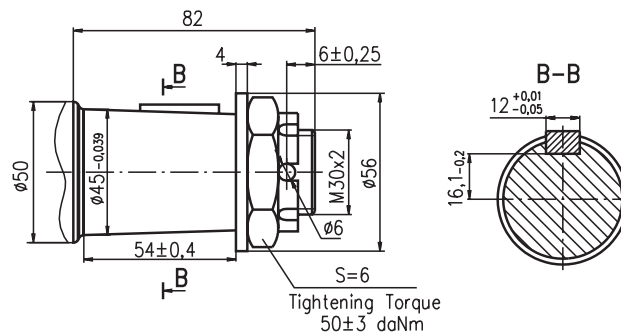

PERMISSIBLE SHAFT LOADS

The curves apply to a B10 bearing life (ISO281) of 2000 hours at 200 RPM.

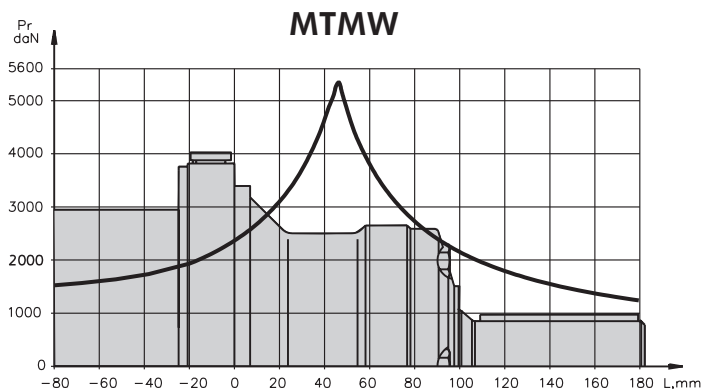
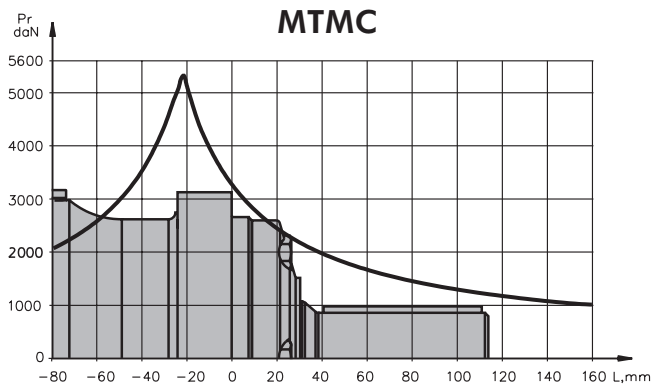
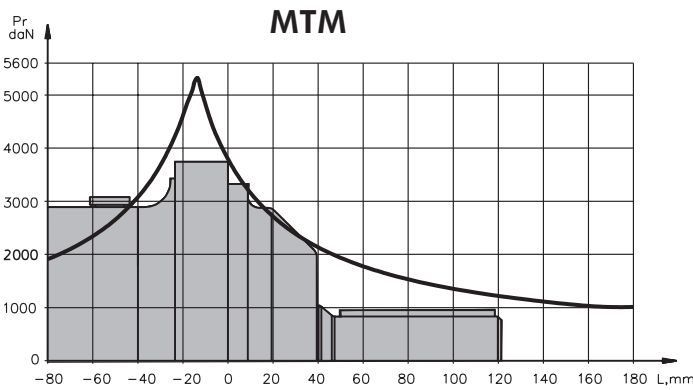

OUTLINE DIMENSIONS REFERENCE FOR MTMV

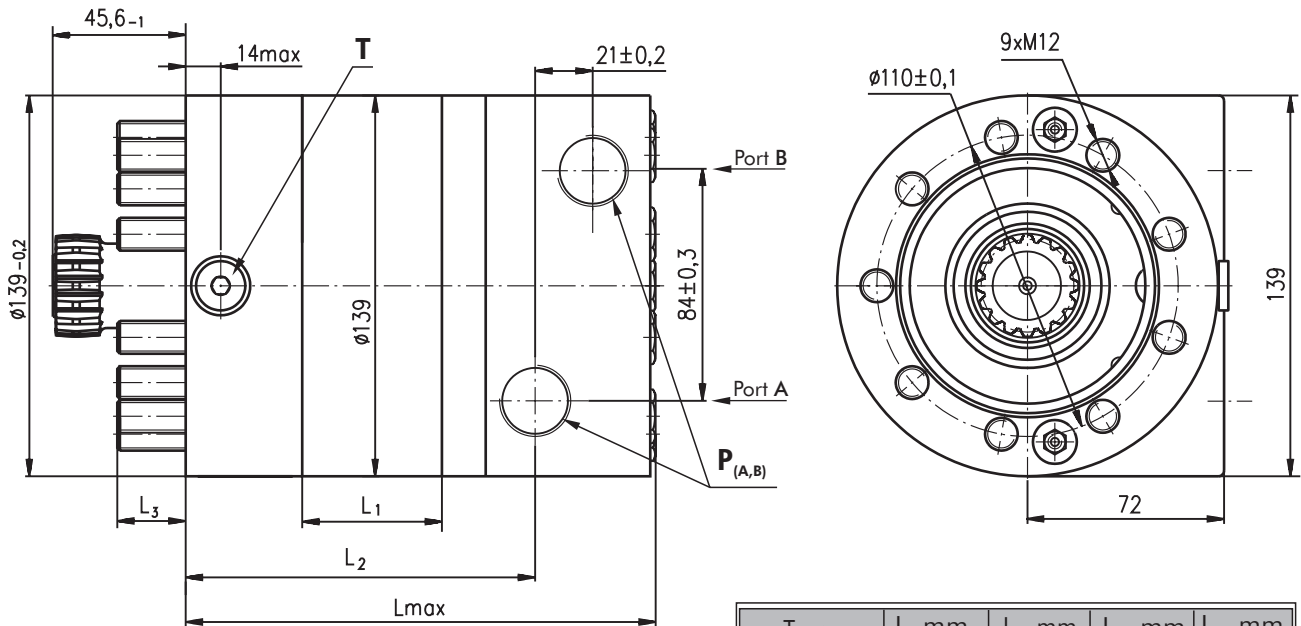

P_(A, B): 2xG3/4 - 17 mm depth
T : G1/4 12 mm depth (plugged)

Standard Rotation
 Viewed from Shaft End
 Port A Pressurized - CW
 Port B Pressurized - CCW

Reverse Rotation
 Viewed from Shaft End
 Port A Pressurized - CCW
 Port B Pressurized - CW

Type	L, mm	L ₁ , mm	L ₂ , mm	L ₃ , mm
MTMV 200	151	25	106,5	27,8
MTMV 250	157	31,3	112,8	26,5
MTMV 315	167	40,5	122	22,3
MTMV 400	177	51	132,5	21,8
MTMV 470	185	59	140,5	23,8
MTMV 500	191	65	146,5	27,8
MTMV 630	187	61	142,5	26,8
MTMV 725	196	70	151,5	27,8

DIMENSIONS OF THE ATTACHED COMPONENT

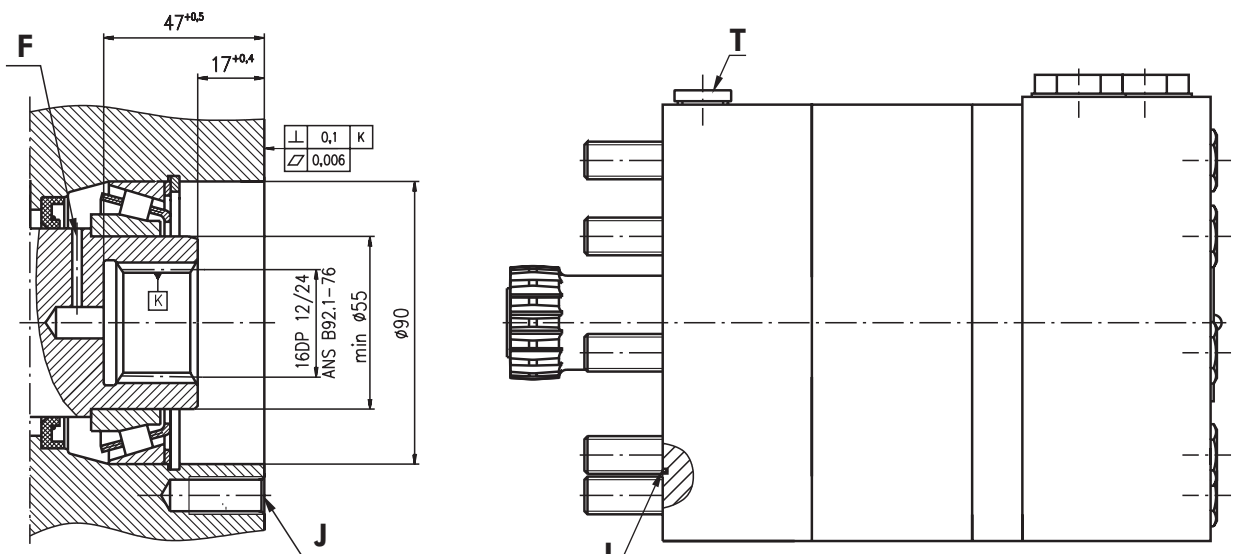

F: Oil circulation hole
J: 9xM12-30 mm depth, 40°, Ø110±0,1

I: O- Ring 93x1,5mm
T: Drain connection G1/4

OUTLINE DIMENSIONS REFERENCE FOR MTM6V

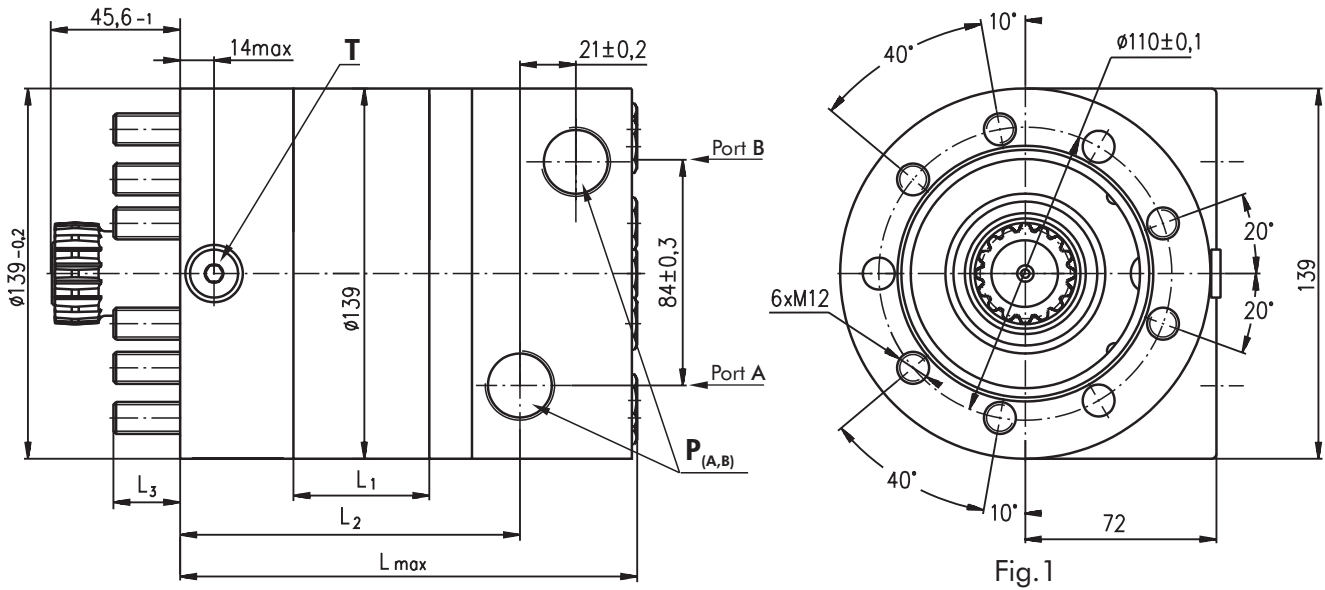

Fig. 1

P_(A, B): 2xG3/4 - 17 mm depth
T : G1/4 12 mm depth (plugged)

Standard Rotation Viewed from Shaft End Port A Pressurized - CW Port B Pressurized - CCW	Reverse Rotation Viewed from Shaft End Port A Pressurized - CCW Port B Pressurized - CW
--	---

Type	L, mm	L ₁ , mm	L ₂ , mm	L ₃ , mm
MTM6V 200	151	25	106,5	27,8
MTM6V 250	157	31,3	112,8	26,5
MTM6V 315	167	40,5	122	22,3
MTM6V 400	177	51	132,5	21,8
MTM6V 470	185	59	140,5	23,8
MTM6V 500	191	65	146,5	27,8
MTM6V 630	187	61	142,5	26,8
MTM6V 725	196	70	151,5	27,8

DIMENSIONS OF THE ATTACHED COMPONENT FOR MTM6V

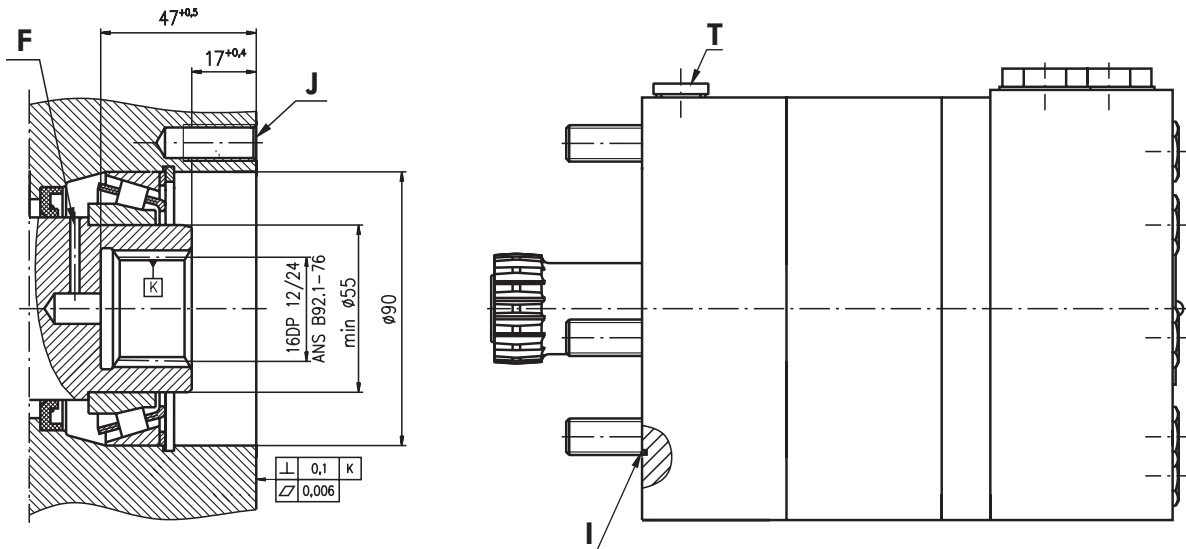

F: Oil circulation hole
J: 9xM12-30 mm depth, 40°, $\phi 110 \pm 0,1$
 or 6xM12-30 mm depth, situated in accordance with the bolts M12, shown on Fig. 1, $\phi 110 \pm 0,1$
I: O- Ring 93x1,5mm
T: Drain connection G1/4

DRAIN CONNECTION

A drain line ought to be used when pressure in the return line can exceed the permissible pressure. It can be connected at the drain connection of the attached component. The maximum pressure in the drain line is limited by the attached component and its shaft seal.

The drain line must be possible for oil to flow freely between motor and attached component and must be led to the tank. The maximum pressure in the drain line is limited by the attached component and its seal.

INTERNAL SPLINE DATA FOR THE ATTACHED COMPONENT

Standard ANS B92.1-1976, class 5
 [m=2.1166; corrected x.m=+1,0]

Fillet Root Side Fit		mm
Number of Teeth	z	16
Pitch DP		12/24
Pressure Angle		30°
Pitch Dia.	D	33,8656
Major Dia.	D _{ri}	38,4 ^{+0,4}
Minor Dia.	D _i	32,15 ^{+0,04}
Space Width [Circular]	L _o	4,516±0,037
Fillet Radius	R	0,5
Max. Measurement between Pin	L	26,9 ^{+0,10}
Pin Dia.	d	4,835±0,001

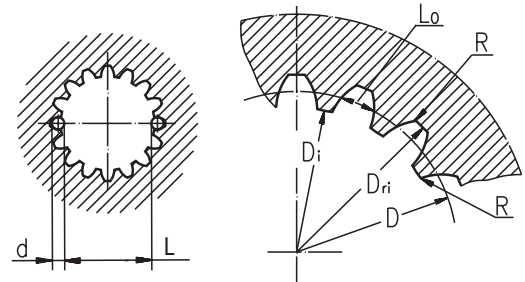

Hardening Specification:
 on the surface HV=750±50
 0,7±0,2 mm under the surface HV=560
 Material 20 MoCr4 DIN 17210 or better

ORDER CODE

	1	2	3	4	5	6
M T M						

Pos. 1 - Mounting Flange

- omit - 4-Bolt flange, spigot dia. ø160, BC ø200
- C** - 4-Bolt flange, spigot dia. ø125, BC ø160
- W** - Wheel motor
- V** - Veryshort mount, 9xM12 mounting bolts
- 6V** - Veryshort mount, 6xM12 mounting bolts

Pos. 2 - Displacement code

- 200** - 201,4 [cm³/rev]
- 250** - 251,8 [cm³/rev]
- 315** - 326,3 [cm³/rev]
- 400** - 410,9 [cm³/rev]
- 470** - 475,0 [cm³/rev]
- 500** - 523,6 [cm³/rev]
- 630** - 631,2 [cm³/rev]
- 725** - 724,3 [cm³/rev]

Pos. 3 - Shaft Extensions*

- C** - ø40 straight, Parallel key A12x8x70 DIN6885
- K** - ø45 tapered 1:10, Parallel key B12x8x28 DIN6885
- SH** - ø1½" splined 17T ANSI B92.1-1976

Pos. 4 - Ports

- omit - BSPP (ISO 228)

Pos. 5 - Special Features [\(see page 65\)](#)

Pos. 6 - Design Series

- omit - Factory specified

NOTES:

- * The permissible output torque for shafts must be not exceeded!
- ** Color at customer's request.

The hydraulic motors are mangano-phosphatized as standard.

HYDRAULIC MOTORS MV



APPLICATION

- » Conveyors
- » Metal working machines
- » Machines for agriculture
- » Road building machines
- » Mining machinery
- » Food industries
- » Special vehicles
- » Plastic and rubber machinery etc.

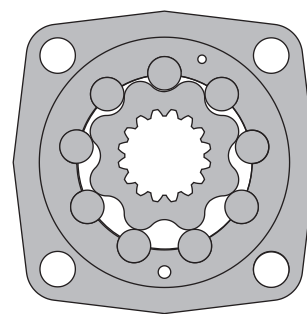

CONTENTS

Specification data	56
Function diagrams	57 ÷ 59
Permissible shaft loads	59
Dimensions and mounting	60
Dimensions and mounting- MVS	61
Dimensions and mounting- MVV	62
Internal Spline data	63
Tacho connection	63
Shaft extensions	64
Order code	64

OPTIONS

- » Model- Disc valve, roll-gerotor
- » Flange and wheel mount
- » Short motor
- » Tacho connection
- » Speed sensing
- » Side ports
- » Shafts- straight, splined and tapered
- » Metric and BSPP ports
- » Other special features

GENERAL

Displacement, [cm ³ /rev.]	314,5 ÷ 801,8
Max. Speed, [RPM]	250 ÷ 510
Max. Torque, [daNm]	92 ÷ 188
Max. Output, [kW]	42,5 ÷ 53,5
Max. Pressure Drop, [bar]	160 ÷ 200
Max. Oil Flow, [l/min]	160 ÷ 200
Min. Speed, [RPM]	5 ÷ 10
Permissible Shaft Loads, [daN]	P _a = 1500
Pressure fluid	Mineral based- HLP(DIN 51524) or HM(ISO 6743/4)
Temperature range, [°C]	-30 ÷ 90
Optimal Viscosity range, [mm ² /s]	20 ÷ 75
Filtration	ISO code 20/16 (Min. recommended fluid filtration of 25 micron)

Oil flow in drain line

Pressure drop (bar)	Viscosity (mm ² /s)	Oil flow in drain line (l/min)
140	20	3
	35	2
210	20	6
	35	4

Pressure Losses

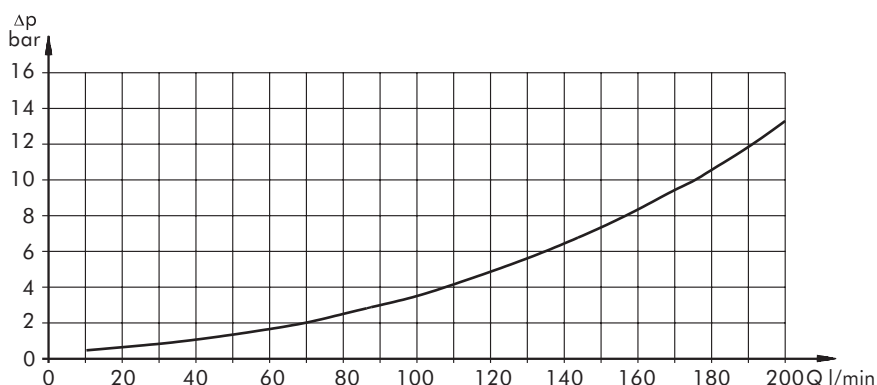

SPECIFICATION DATA

Type		MV 315	MV 400	MV 500	MV 630	MV 800
Displacement [cm ³ /rev.]		314,5	400,9	499,6	629,1	801,8
Max. Speed, [RPM]	cont.	510	500	400	315	250
	Int.*	630	600	480	380	300
Max. Torque [daNm]	cont.	92	118	146	166	188
	Int.*	111	141	176	194	211
	peak**	129	164	205	221	247
Max. Output [kW]	cont.	42,5	53,5	53,5	48	42,5
	int.*	51	64	64	56	48
Max. Pressure Drop [bar]	cont.	200	200	200	180	160
	Int.*	240	240	240	210	180
	peak**	280	280	280	240	210
Max. Oil Flow [l/min]	cont.	160	200	200	200	200
	Int.*	200	240	240	240	240
Max. Inlet Pressure [bar]	cont.	210	210	210	210	210
	Int.*	250	250	250	250	250
	peak**	300	300	300	300	300
Max. Return Pressure without Drain Line or Max. Pressure in Drain Line , [bar]	cont. 0-100 RPM	60	60	60	60	60
	cont. 100-300 RPM	30	30	30	30	30
	cont. >300 RPM	20	20	20	20	20
	Int.* 0-max. RPM	75	75	75	75	75
Max. Return Pressure with Drain Line [bar]	cont.	140	140	140	140	140
	Int.*	175	175	175	175	175
	peak**	210	210	210	210	210
Max. Starting Pressure with Unloaded Shaft, [bar]		8	8	8	8	8
Min. Starting Torque [daNm]	at max. press. drop cont.	71	91	113	133	151
	at max. press. drop Int.*	85	109	136	155	170
Min. Speed***, [RPM]		10	9	8	6	5
Weight, avg. [kg]	MV	31,8	32,6	33,5	34,9	36,5
	MVW	32,4	33,2	34,1	35,5	37,1
	MVS	22,7	23,5	24,4	25,6	27,7

* Intermittent operation: the permissible values may occur for max. 10% of every minute.

** Peak load: the permissible values may occur for max. 1% of every minute.

*** For speeds of 5 RPM lower than given, consult factory or your regional manager.

- 1) Intermittent speed and intermittent pressure must not occur simultaneously.
- 2) Recommended filtration is per ISO cleanliness code 20/16. A nominal filtration of 25 micron or better.
- 3) Recommend using a premium quality, anti-wear type mineral based hydraulic oil, HLP(DIN51524) or HM(ISO6743/4).
If using synthetic fluids consult the factory for alternative seal materials.
- 4) Recommended minimum oil viscosity 13 mm²/s at 50°C.
- 5) Recommended maximum system operating temperature is 82°C.
- 6) To assure optimum motor life fill with fluid prior to loading and run at moderate load and speed for 10-15 minutes.

FUNCTION DIAGRAMS

MV 315

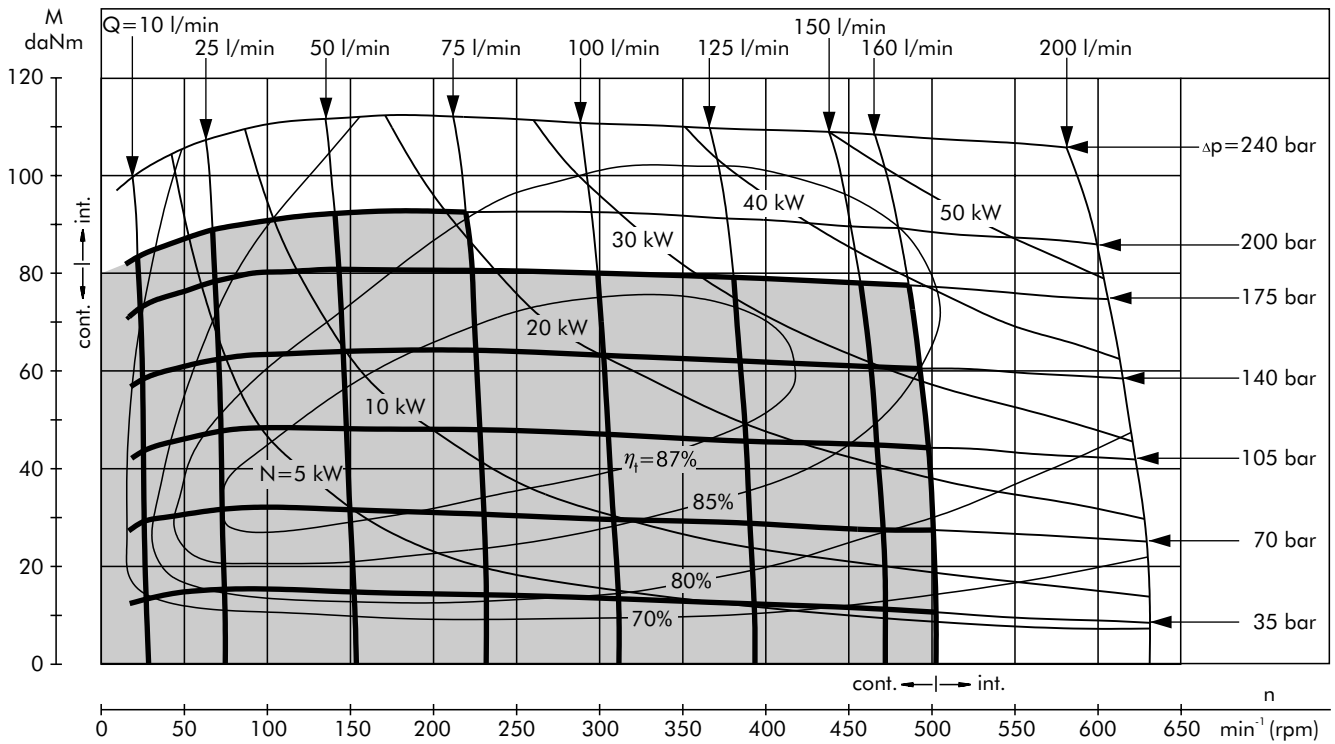

MV 400

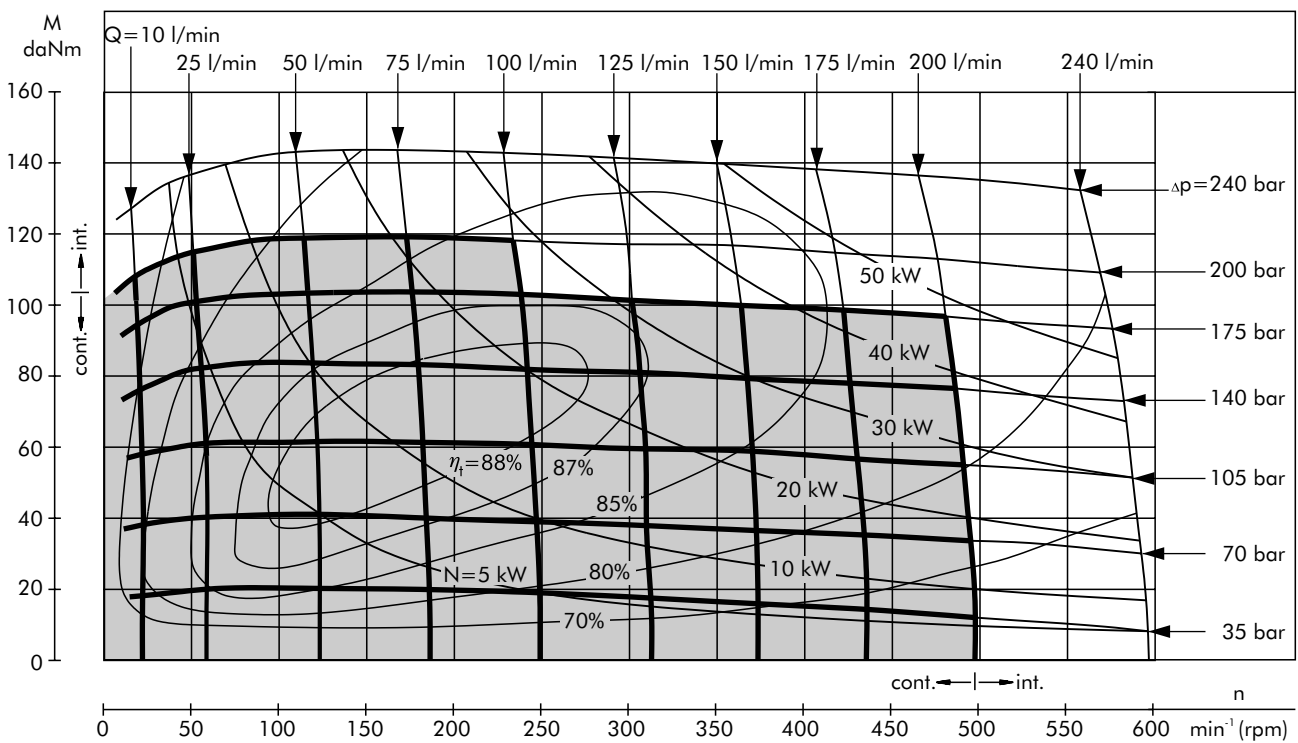

The function diagrams data was collected at back pressure $5 \div 10$ bar and oil with viscosity of $32 \text{ mm}^2/\text{s}$ at 50°C .

FUNCTION DIAGRAMS

MV 500

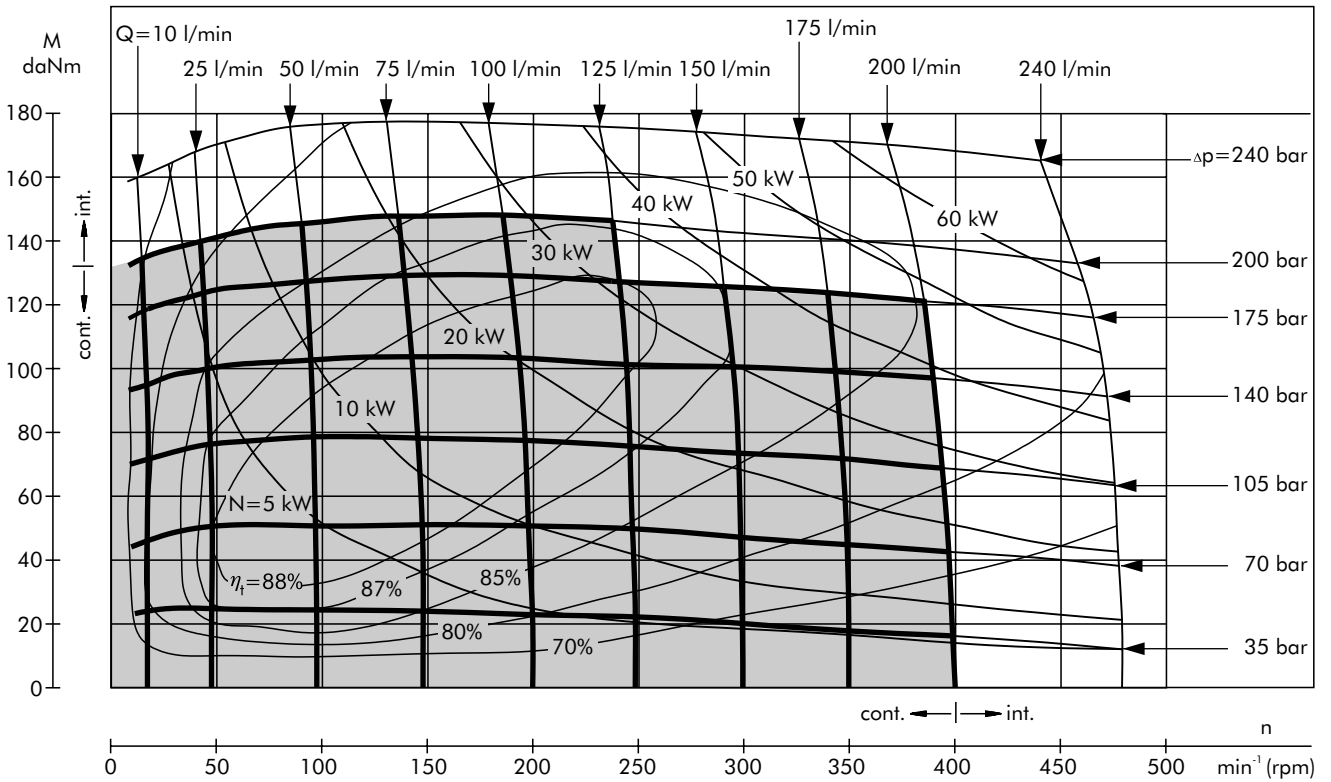

MV 630

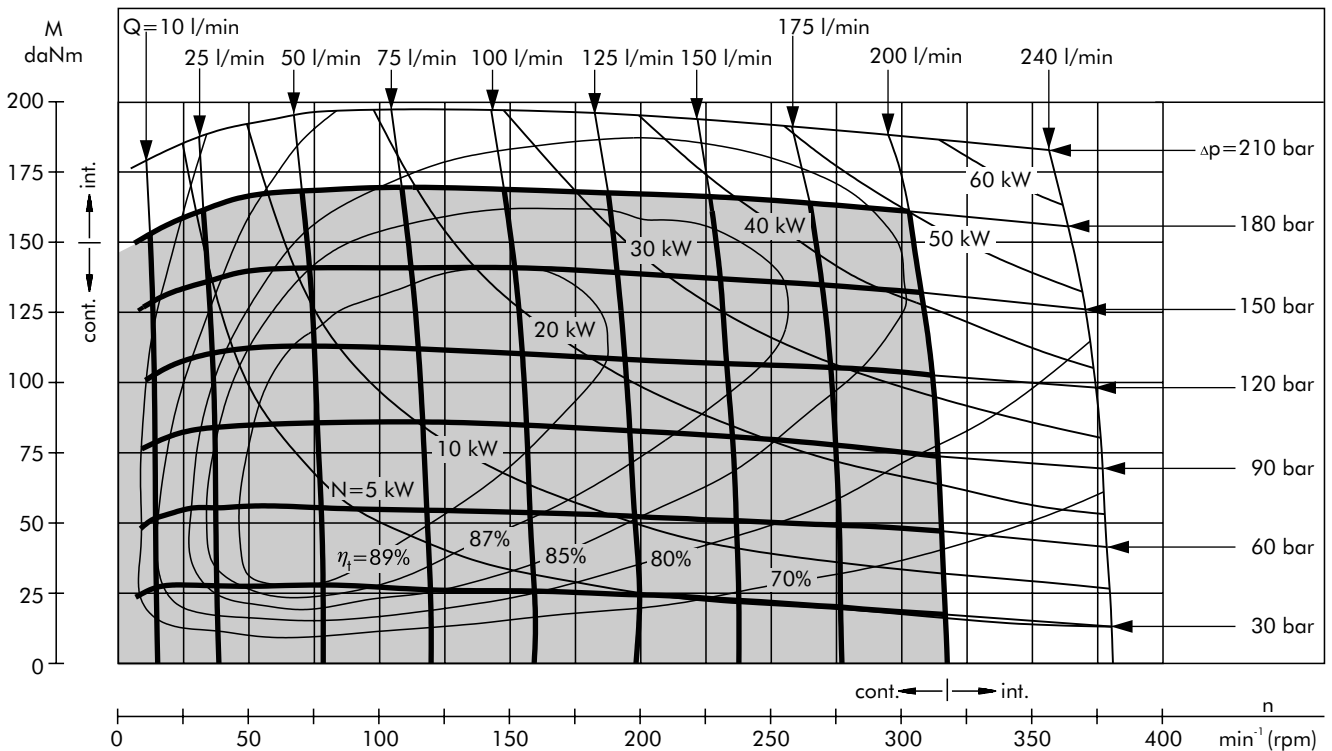

The function diagrams data was collected at back pressure 5 ÷ 10 bar and oil with viscosity of 32 mm²/s at 50° C.

FUNCTION DIAGRAMS

MV 800

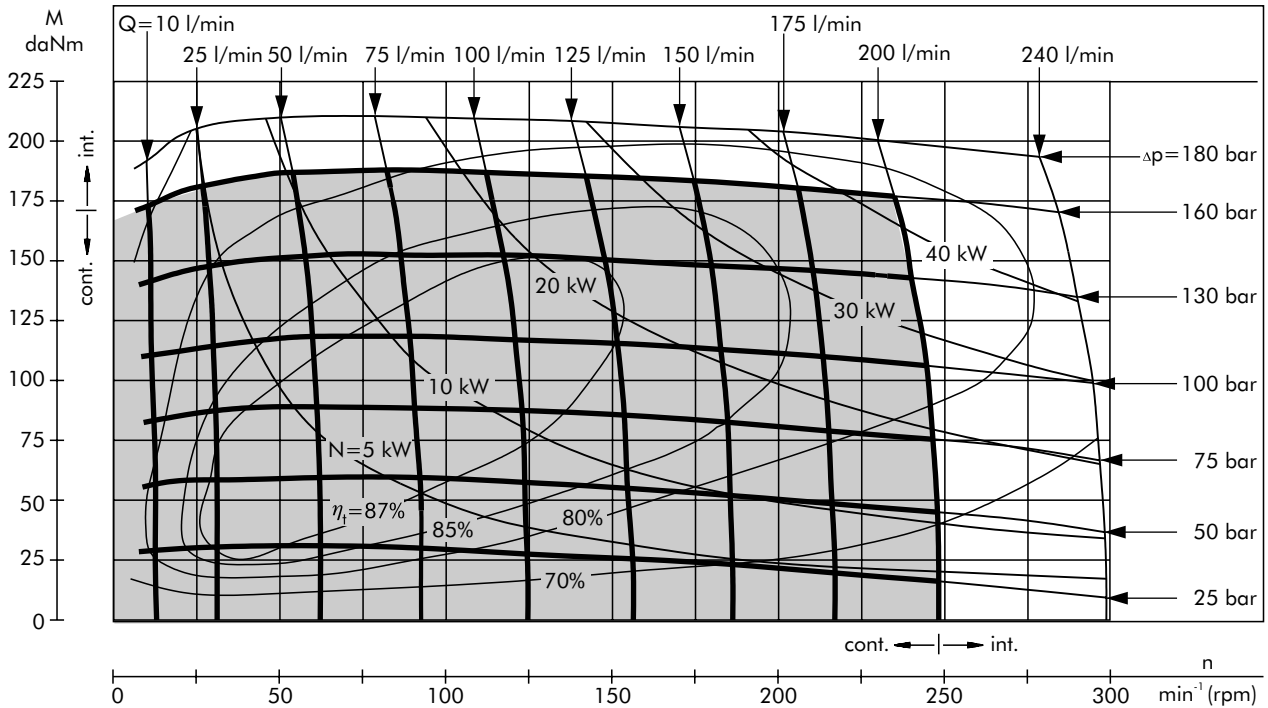

The function diagrams data was collected at back pressure $5 \div 10$ bar and oil with viscosity of $32 \text{ mm}^2/\text{s}$ at 50°C .

PERMISSIBLE SHAFT LOADS

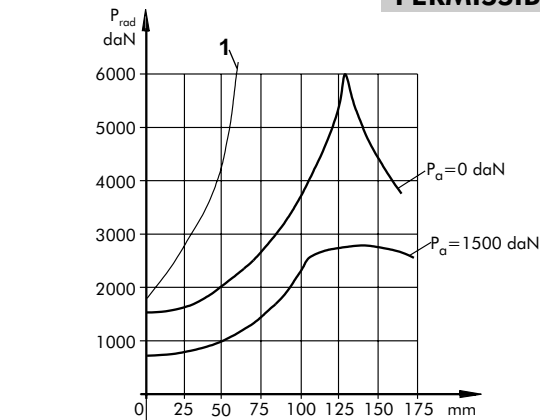

The output shaft runs in tapered bearings that permit high axial and radial forces. Curve "1" shows max. radial shaft load. Any shaft load exceeding the values quoted in the curve will seriously reduce motor life. The two other curves apply to a B10 bearing life of 3000 hours at 200 RPM.

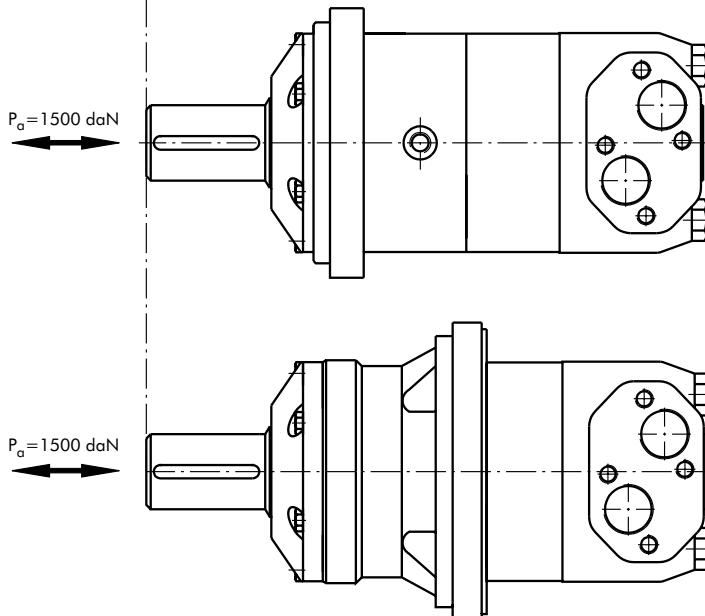

DIMENSIONS AND MOUNTING DATA

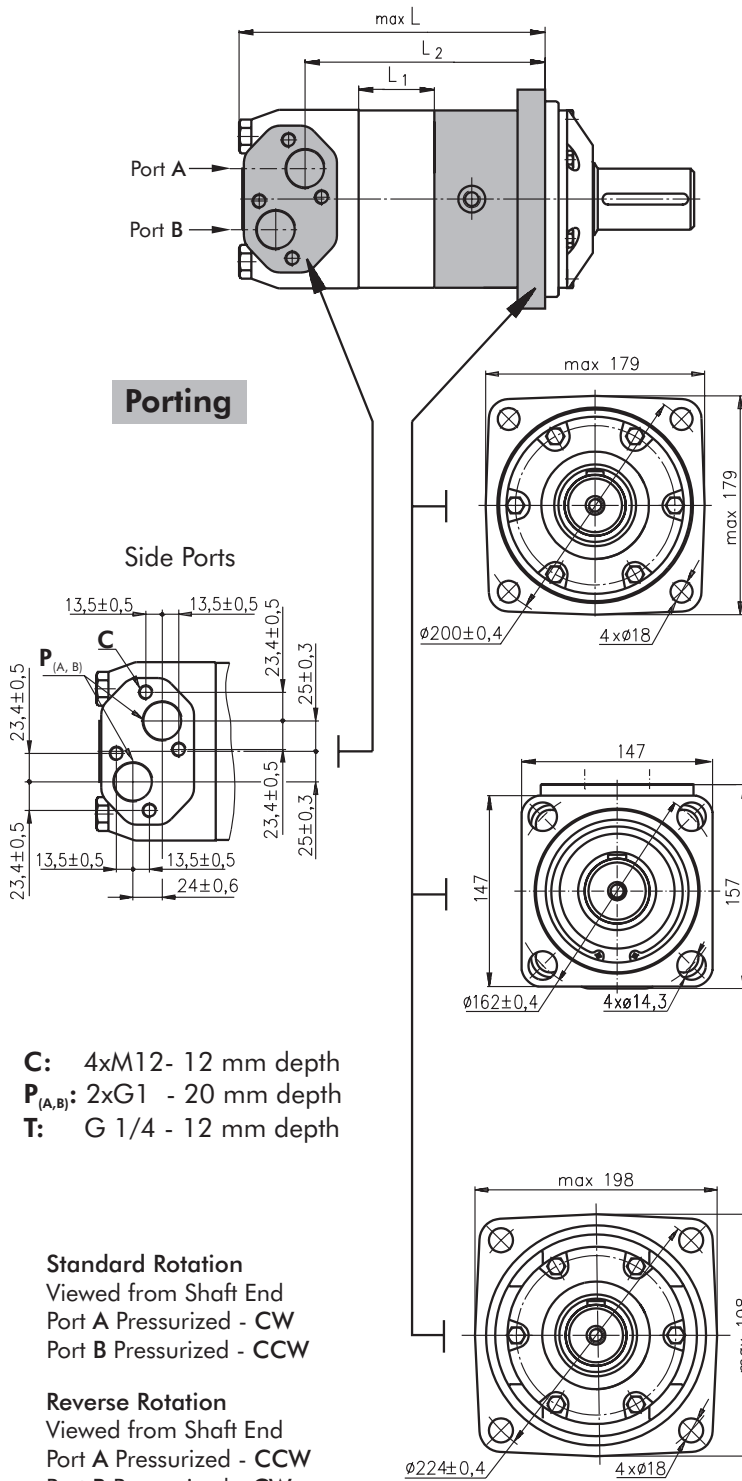

Mounting

Square Mount (4 Holes)

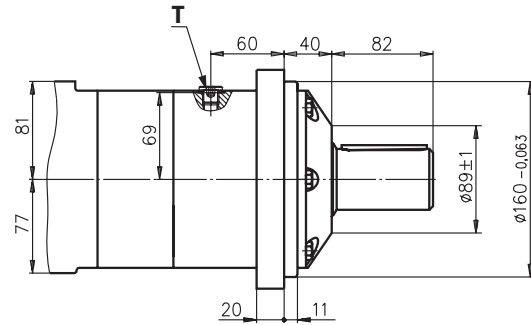

C SAE C Mount

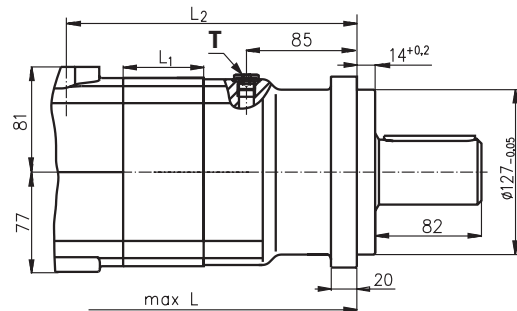

W Wheel Mount

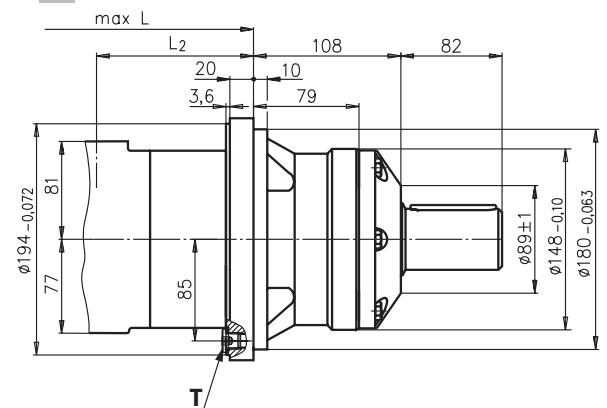

Type	L, mm	L ₂ , mm	Type	L, mm	L ₂ , mm	Type	L, mm	L ₂ , mm	*L ₁ , mm
MV 315	214,5	160	MVC 315	238,25	184,26	MW 315	146	92	21,5
MV 400	221,5	167	MVC 400	245,25	191,26	MW 400	153	99	28,5
MV 500	229,5	175	MVC 500	253,25	199,26	MW 500	161	107	36,5
MV 630	240,0	186	MVC 630	263,75	209,76	MW 630	172	118	47,0
MV 800	254,0	200	MVC 800	277,75	223,76	MW 800	185	132	61,0

* The width of the roll-gerotor is 4 mm greater than L₁.

DIMENSIONS AND MOUNTING

S Short Mount

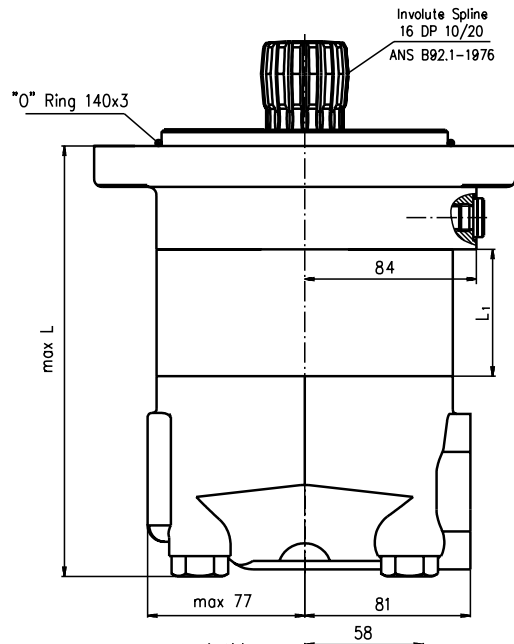
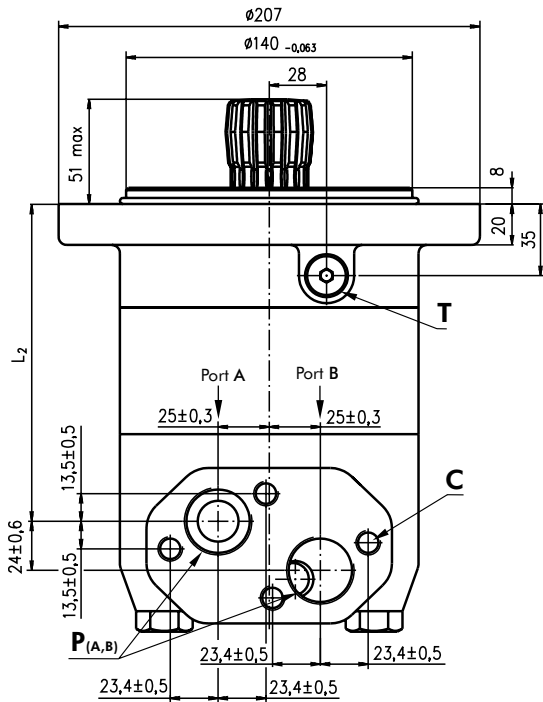

- C:** 4xM12- 12 mm depth
- P_(A,B):** 2xG1 - 20 mm depth
- T:** G 1/4 - 12 mm depth

Type	L, mm	*L ₁ , mm	L ₂ , mm
MVS 315	171	22,0	117
MVS 400	179	29,0	124
MVS 500	186	37,0	132
MVS 630	197	47,5	143
MVS 800	211	61,5	157

Standard Rotation
Viewed from Shaft End
Port A Pressurized - CW
Port B Pressurized - CCW

Reverse Rotation
Viewed from Shaft End
Port A Pressurized - CCW
Port B Pressurized - CW

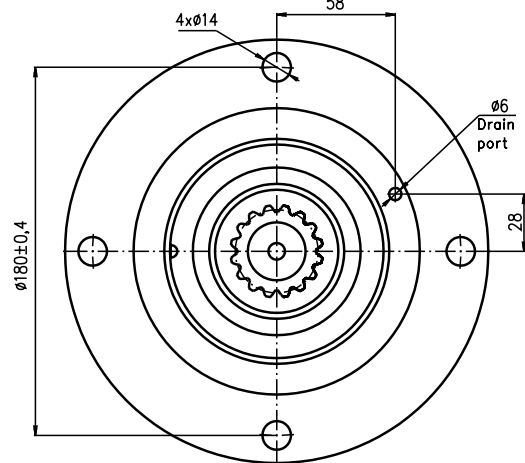

* The width of the gerolator is 4 mm greater than L₁.

DIMENSIONS OF THE ATTACHED COMPONENT

MVS

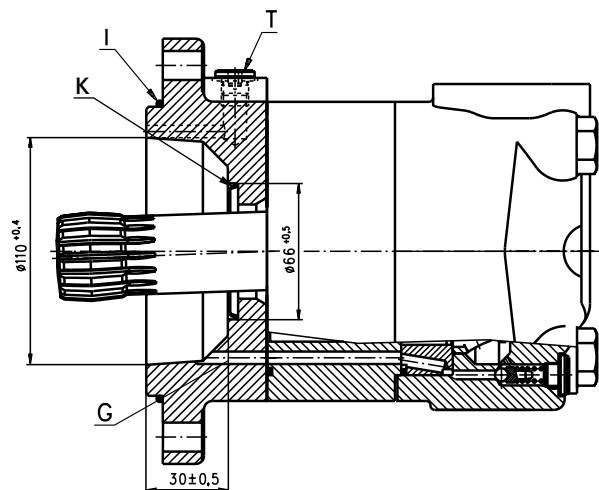
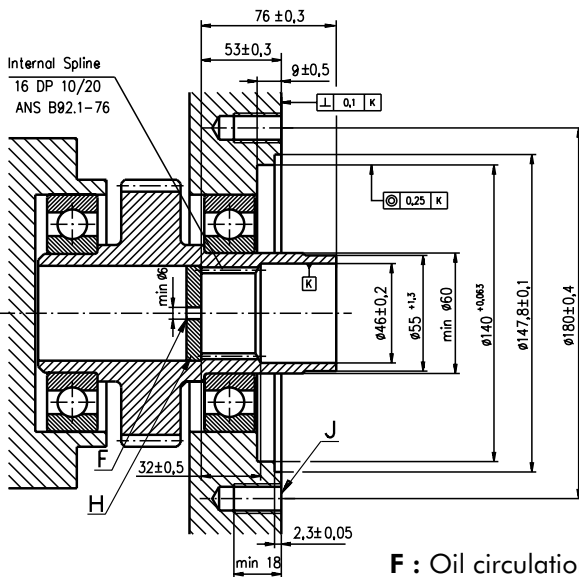

- F:** Oil circulation hole
- G:** Internal drain channel
- H:** Hardened stop plate
- I:** O- Ring 140x3mm
- J:** 4xM12-18 mm depth, 90°
- K:** Conical seal ring
- T:** Drain connection G1/4 - 12 mm depth

DIMENSIONS AND MOUNTING

V Very Short Mount

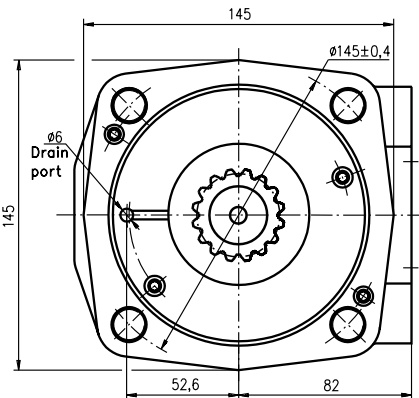
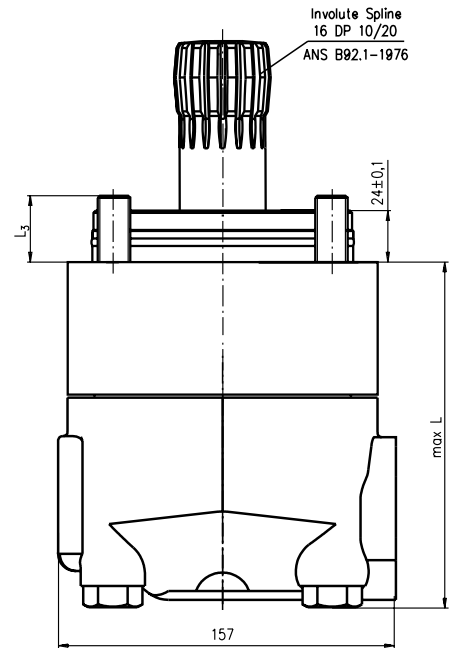
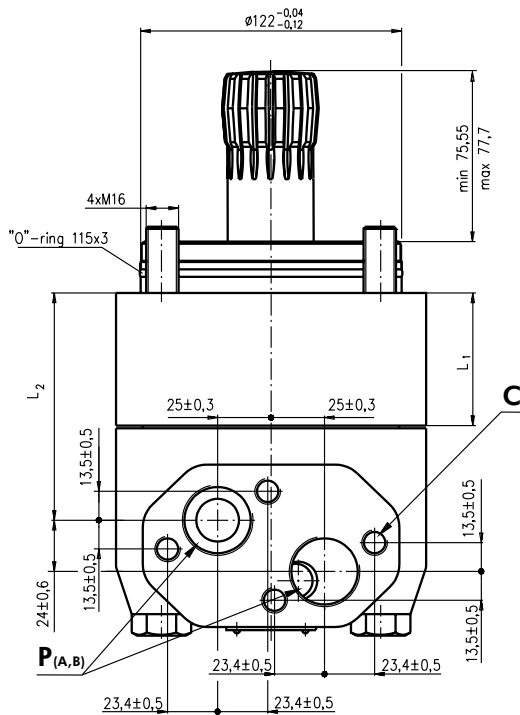

C: 4xM12- 12 mm depth

P(A,B): 2xG1 - 20 mm depth

Type	L, mm	*L ₁ , mm	L ₂ , mm	L ₃ , mm
MVV 315	121,5	22,0	68,0	29,5
MVV 400	128,5	29,0	75,0	32,5
MVV 500	136,5	37,0	83,0	34,5
MVV 630	147,0	47,5	93,0	34,0
MVV 800	161,0	61,5	107,5	30,0

Standard Rotation
Viewed from Shaft End
Port A Pressurized - CW
Port B Pressurized - CCW

Reverse Rotation
Viewed from Shaft End
Port A Pressurized - CCW
Port B Pressurized - CW

* The width of the roll-gerotor is 4 mm greater than L₁.

DIMENSIONS OF THE ATTACHED COMPONENT

MVV

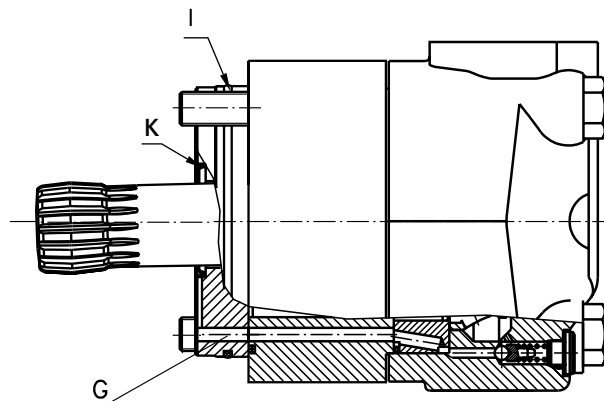
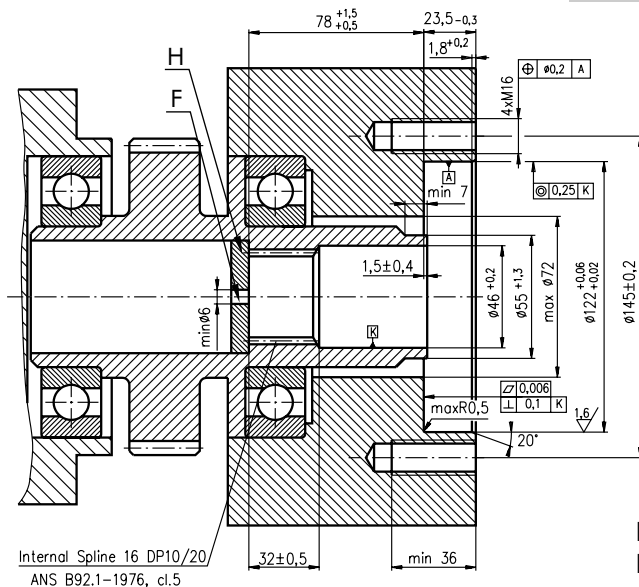

Internal Spline 16 DP10/20
ANS B92.1-1976, cl.5

F: Oil circulation hole
H: Hardened stop plate
G: Internal drain channel

I: O- Ring 115x3mm
K: Conical seal ring

DRAIN CONNECTION

A drain line ought to be used when pressure in the return line can exceed the permissible pressure. It can be connected:

- For MVS at the drain port of the motor;
- For MVV at the drain connection of the attached component. The maximum pressure in the drain line is limited by the attached component and its shaft seal.

The drain line must be possible for oil to flow freely between motor and attached component and must be led to the tank. The maximum pressure in the drain line is limited by the attached component and its seal.

INTERNAL SPLINE DATA FOR THE ATTACHED COMPONENT

Standard ANS B92.1-1976, class 5
 [m=2.54; corrected x.m=+1,0]

Fillet Root Side Fit		mm
Number of Teeth	z	16
Diametral Pitch	DP	10/20
Pressure Angle		30°
Pitch Dia.	D	40,640
Major Dia.	D _{ri}	45,2 ^{+0,4}
Minor Dia.	D _i	38,5 ^{+0,039}
Space Width [Circular]	Lo	5,18±0,037
Fillet Radius	R _{min}	0,4
Max. Measurement between Pin	L	32,47 ^{+0,15}
Pin Dia.	d	5,6±0,001

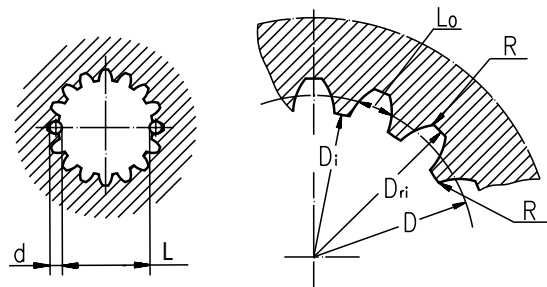

Hardening Specification:
 HV=750±50 on the surface
 HV=560 at 0,7±0,2 mm case depth
 Material 20 MoCr4 EN 10084 or better

MOTOR WITH TACHO CONNECTION

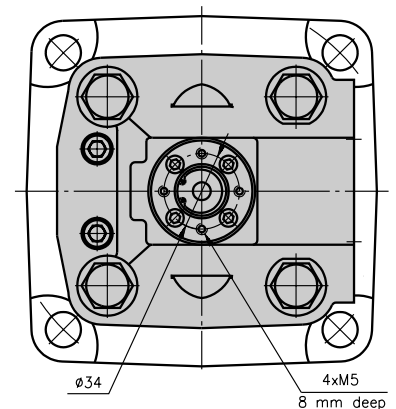
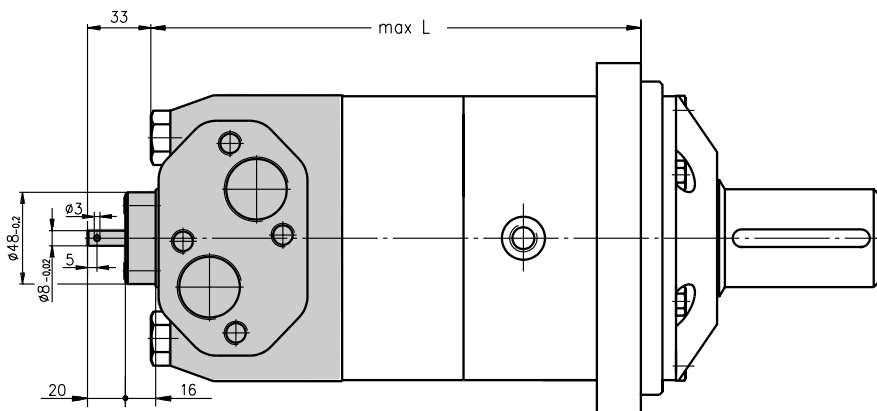

SHAFT EXTENSIONS

C - $\varnothing 50$ straight, Parallel key A14x9x70 DIN 6885

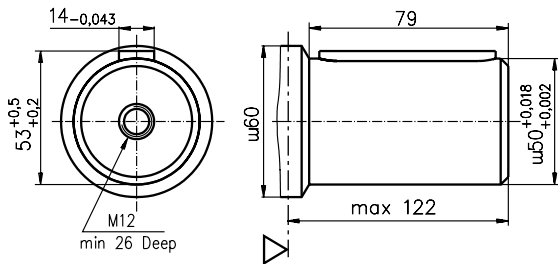

CO - $\varnothing 2\frac{1}{4}$ " [57,15] straight, Parallel key $\frac{1}{2}$ " x $\frac{1}{2}$ " x $2\frac{1}{4}$ " BS46

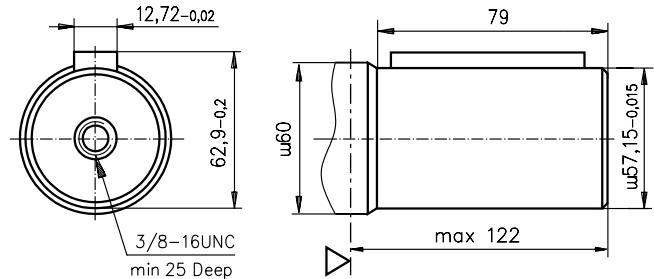

SH - $\varnothing 2\frac{1}{8}$ " splined, 16 DP 8/16 ANS B92.1-1976

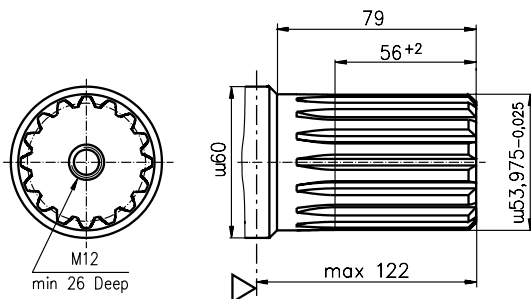

K - tapered 1:10, Parallel key B16x10x32 DIN 6885

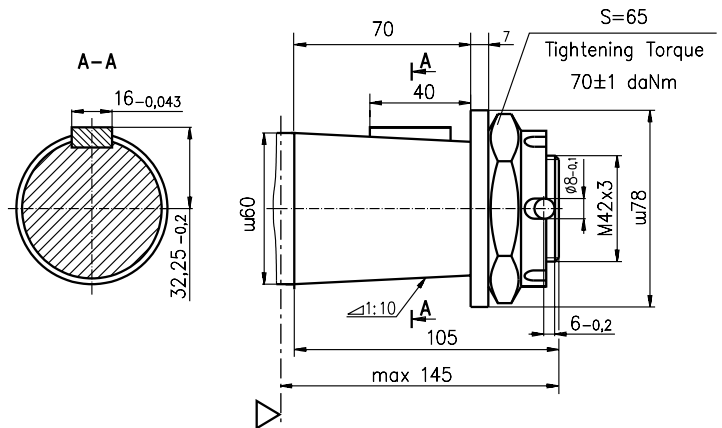

▽ - Motor Mounting Surface

ORDER CODE

	1	2	3	4	5
M V					

Pos. 1 - Mounting Flange

omit - Square mount, four holes

C	- SAE C mount
W	- Wheel mount
S	- Short mount
V	- Very short mount

Pos. 2 - Displacement code

315	- 314,5 [cm ³ /rev]
400	- 400,9 [cm ³ /rev]
500	- 499,6 [cm ³ /rev]
630	- 629,1 [cm ³ /rev]
800	- 801,8 [cm ³ /rev]

Pos. 3 - Shaft extensions*

omit - for **S** and **V** mounting flange

C	- $\varnothing 50$ straight, Parallel key A14x9x70 DIN6885
CO	- $\varnothing 2\frac{1}{4}$ " straight, Parallel key $\frac{1}{2}$ " x $\frac{1}{2}$ " x $2\frac{1}{4}$ " BS46
SH	- $\varnothing 2\frac{1}{8}$ " splined, ANS B92.1-1976
K	- $\varnothing 60$ tapered 1:10, Parallel key B16x10x32 DIN6885

Pos. 4 - Special Features (see page 64)

Pos. 5 - Design Series

omit - Factory specified

NOTES:

* The permissible output torque for shafts must not be exceeded!

The hydraulic motors are mangano- phosphatized as standard.

MOTOR SPECIAL FEATURES

Special Feature Description	Order Code	Motor type				
		MS	MSY	MT	MTM	MV
Motor for Speed Sensor*	RS	○	○	○	○	○
Tacho Connection**	T	○	○	○	-	○
Low Leakage	LL	○	○	○	○	○
Low Speed Valving	LSV	○	○	○	○	○
Reverse Rotation	R	○	○	○	○	○
Paint***	P	○	○	○	○	○
Corrosion Protected Paint***	PC	○	○	○	○	○
Check Valves		S	S	S	S	S

- Optional
- Not applicable
- S Standard

* for sensor ordering see pages 66-67.

** only for side ports.

*** color at customer's request.

MOTORS WITH SPEED SENSOR

MS(Y)...RS

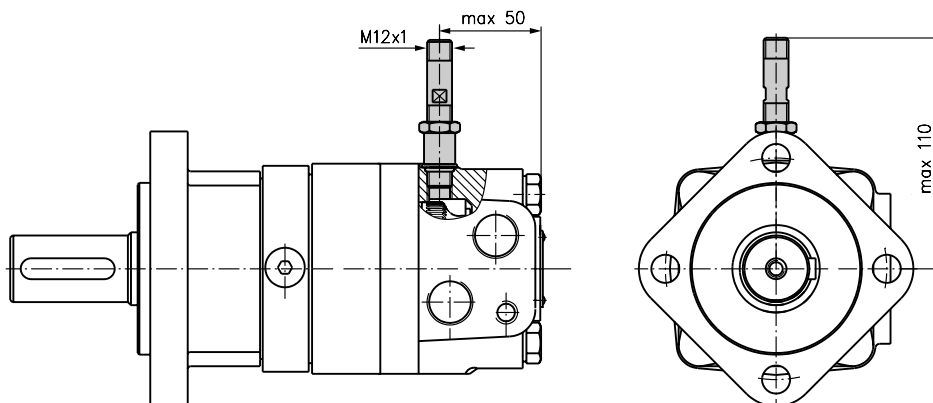

MT...RS

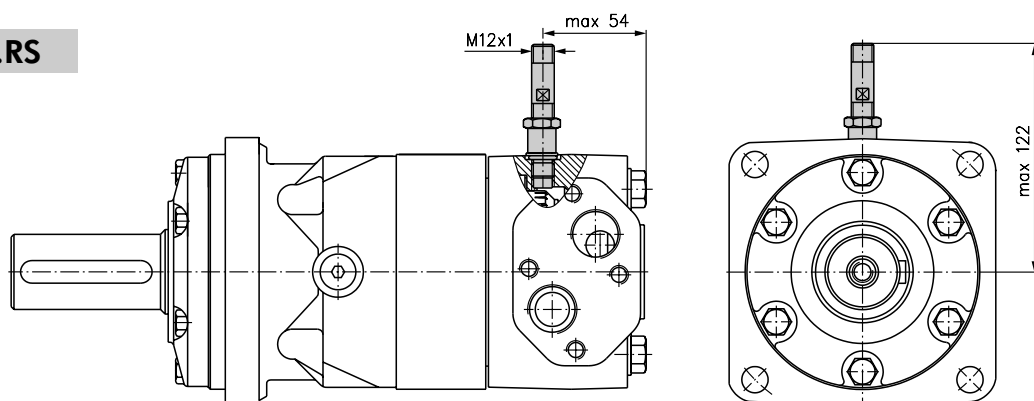

MTM...RS

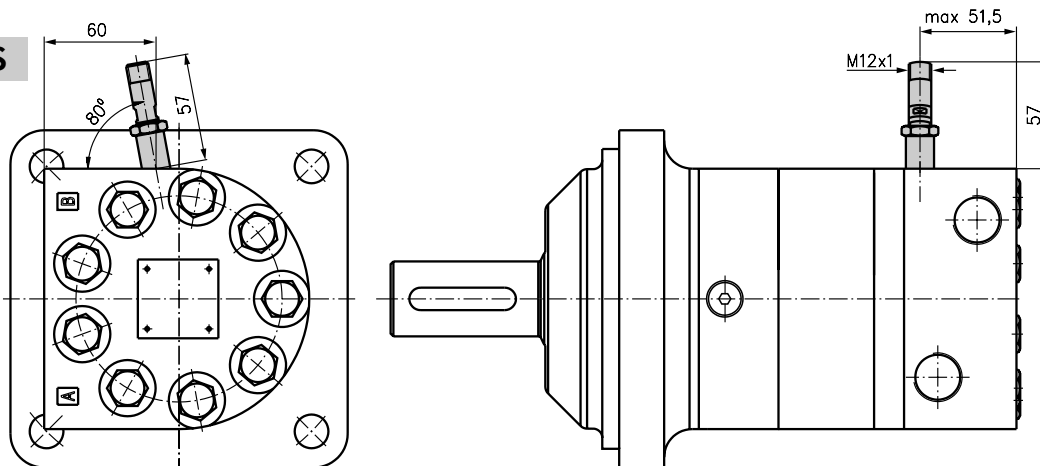

MV...RS

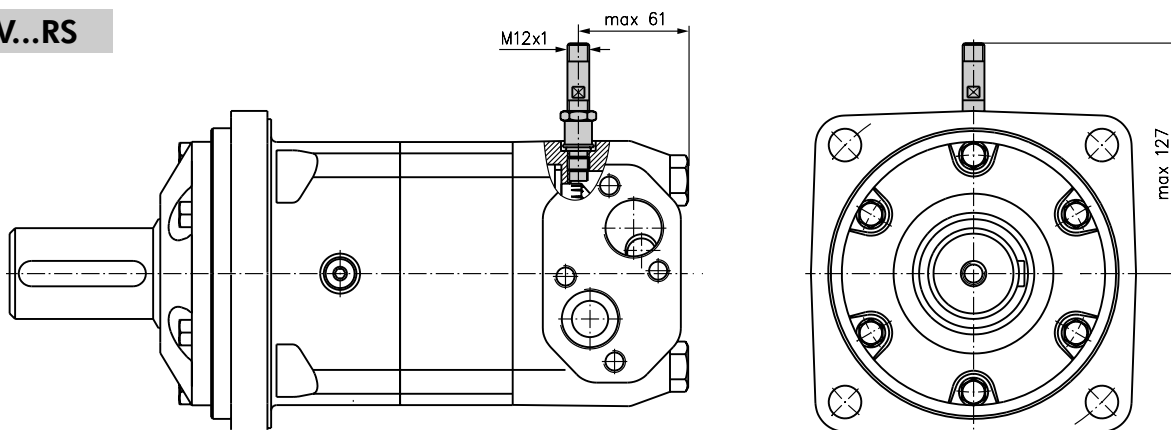

TECHNICAL DATA OF THE SPEED SENSOR

Technical data

Frequency range	0...15 000 Hz
Output	PNP, NPN
Power supply	10...36 VDC
Current input	20 mA (@24 VDC)
Ambient Temperature	minus 40... plus 125°C
Protection	IP 67
Plug connector	M12-Series
Mounting principle	ISO 6149

Output signal

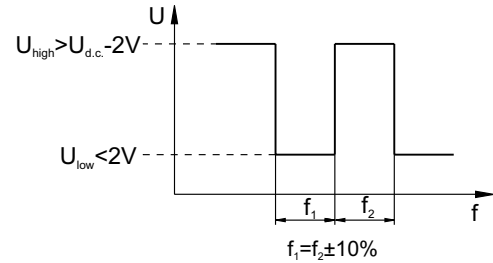

Load max.: $I_{high} = I_{low} < 50\text{mA}$

No load current, max: 20 mA

Motor type	MS	MT	MTM	MV
Pulses per revolution	54	84	84	102

Wiring diagrams

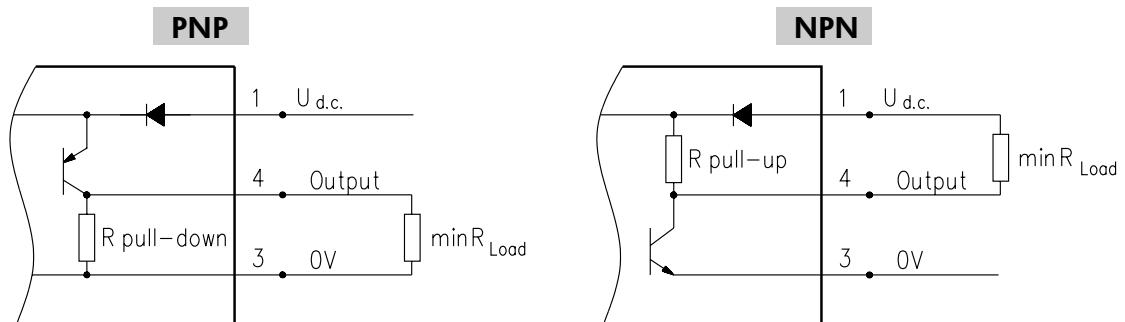

$$R_{Load} [k\Omega] = U_{d.c.} [V] / I_{max} [mA]$$

Stick type

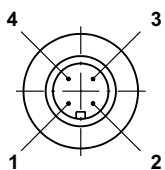

Terminal No.	Connection	Cable Output
1	$U_{d.c.}$	Brown
2	No connection	White
3	0V	Blue
4	Output signal	Black

Order Code for Speed Sensor

Sensor Code	Output type	Electric connection
RSN	NPN	Connector BINDER 713 series
RSP	PNP	Connector BINDER 713 series
RSNL5	NPN	Cable output 3x0,25; 5m long
RSPL5	PNP	Cable output 3x0,25; 5m long

NOTE: *- The speed sensor is not fitted at the factory, but is supplied in a plastic bag with the motor. For installation see enclosed instructions.

MOTOR APPLICATION

VEHICLE DRIVE CALCULATIONS

1. Motor speed: n , [min^{-1}]

$$n = \frac{2,65 \times v \times i}{R}$$

v - vehicle speed, [km/h];

R - wheel rolling radius, [m];

i - gear ratio between motor and wheels.

If no gearbox, use $i = 1$.

2. Rolling resistance: RR , [daN]

The resistance force resulted in wheels contact with different surfaces:

$$RR = G \times \rho$$

G - total weight loaded on vehicle, [daN];

ρ - rolling resistance coefficient (Table 1).

Table 1

Rolling resistance coefficient In case of rubber tire rolling on different surfaces	
Surface	ρ
Concrete- faultless	0,010
Concrete- good	0,015
Concrete- bad	0,020
Asphalt- faultless	0,012
Asphalt- good	0,017
Asphalt- bad	0,022
Macadam- faultless	0,015
Macadam- good	0,022
Macadam- bad	0,037
Snow- 5 cm	0,025
Snow- 10 cm	0,037
Polluted covering- smooth	0,025
Polluted covering- sandy	0,040
Mud	$0,037 \div 0,150$
Sand- Gravel	$0,060 \div 0,150$
Sand- loose	$0,160 \div 0,300$

3. Grade resistance: GR , [daN]

$$GR = G \times (\sin \alpha + \rho \times \cos \alpha)$$

α - gradient negotiation angle (Table 2)

Table 2

Grade %	α Degrees	Grade %	α Degrees
1%	$0^\circ 35'$	12%	$6^\circ 5'$
2%	$1^\circ 9'$	15%	$8^\circ 31'$
5%	$2^\circ 51'$	20%	$11^\circ 19'$
6%	$3^\circ 26'$	25%	$14^\circ 3'$
8%	$4^\circ 35'$	32%	18°
10%	$5^\circ 43'$	60%	31°

4. Accelerate force: FA , [daN]

Force FA necessary for acceleration from 0 to maximum speed v and time t can be calculated with a formula:

$$FA = \frac{v \times G}{3,6 \times t}, [\text{daN}]$$

FA - accelerate force, [daN];

t - time, [s].

5. Tractive effort: DP , [daN]

Tractive effort DP is the additional force of trailer. This value will be established as follows:

-acc.to constructor's assessment;

-as calculating forces in items 2, 3 and 4 of trailer; the calculated sum corresponds to the tractive effort requested.

6. Total tractive effort: TE , [daN]

Total tractive effort TE is total effort necessary for vehicle motion; that the sum of forces calculated in items from 2 to 5 and increased with 10 % because of air resistance.

$$TE = 1,1 \times (RR + GR + FA + DP)$$

RR - force acquired to overcome the rolling resistance;

GR - force acquired to slope upwards;

FA - force acquired to accelerate (acceleration force);

DP - additional tractive effort (trailer).

7. Motor Torque: M , [daNm]

Necessary torque moment for every hydraulic motor:

$$M = \frac{TE \times R}{N \times i \times \eta_M}$$

N - motor numbers;

η_M - mechanical gear efficiency (if it is available).

8. Cohesion between tire and road covering: M_w , [daNm]

$$M_w = \frac{G_w \times f \times R}{i \times \eta_M}$$

To avoid wheel slipping, it should be observed the following condition $M_w > M$

f - frictional factor;

G_w - total weight over the wheels, [daN].

Table 3

Surface	Frictional factor f
Steel on steel	$0,15 \div 0,20$
Rubber tire on polluted surface	$0,5 \div 0,7$
Rubber tire on asphalt	$0,8 \div 1,0$
Rubber tire on concrete	$0,8 \div 1,0$
Rubber tire on grass	0,4

9.Radial motor loading: P_{rad} , [daN]

When motor is used for vehicle motion with wheels mounted directly on motor shaft, the total radial loading of motor shaft P_{rad} is a sum of motion force and weight force acting on one wheel.

- G_w - Weight held by wheel;
- P_{rad} - Total radial loading of motor shaft;
- M/R - Motion force.

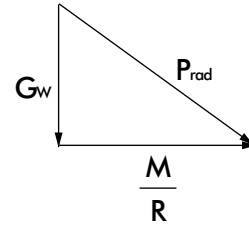

$$P_{rad} = \sqrt{G_w^2 + \left(\frac{M}{R}\right)^2}$$

In accordance with calculated loadings the suitable motor from the catalogue is selected.

DRAINAGE SPACE AND DRAINAGE PRESSURE

Advantages in oil drainage from drain space: Cleaning; Cooling and Seal lifetime prolonging.

