

Miniature hydraulic accumulators type AC for mounting in tapped ports

Operating pressure p_{max} = 500 bar
 Rated volume V_0 = 13 or 40 cm³
 Gas filling pressure $p_{0 max}$ = 250 bar

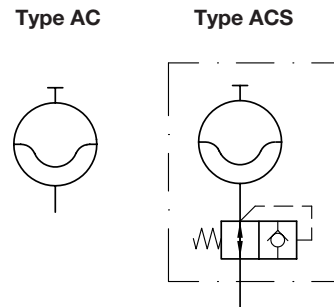

1. General information

The miniature accumulator described here are excepted from the pressure equipment regulation 97/23/EC section 3 (1) 1.1.a and 1.1.b. The pressure limiting valve used for the hydraulic system is sufficient for safe-guarding the permitted pressure level (i.e. the accumulator itself does not require a separate, specially homologated and approved safety valve). Whenever the accumulator is utilized in a section of the hydraulic system exposed to excessive pressure during operation (or in the event of a false setting), and such pressure peak possibly exceeding max pressure p_4 , a simple pressure limitation valve set to this or slightly below p_4 should be provided for this section only.

It is recommended to add a note to the operation manual for the system, which informs the operator to drain all pressure from the system prior to any service/repair on the hydraulic system (DIN 24 346, paragr. 7.4.7); see also sect. 6.

Application

- The miniature accumulators type AC may be used for compensation possible leakage loss in small systems operated in switch-off mode e.g. clamping circuits (prolongation of the off-periods when controlled by pressure switches), or as a source supplying compressed oil in an emergency when the oil supply pump fails to operate. Preference should be given to the AC 40 type in view of the reservoir volume available.
- AC miniature accumulator may also be used to support the switch-over process with fully hydraulic, pressure-controlled idle circulation valves (see D 7529, sect. 5.1).
- A further application of the miniature accumulators type AC is to compensate for changes in volume in specific oil cavities caused by fluctuations in ambient temperature (eg. long-term tests with small, static presses).
- A accumulator may serve furthermore to influence and increase the inherent of pressure scales or other components actuated by a difference in pressure. This makes it possible to avoid or quickly overcome excessive fluctuations in compensating for low-frequency vibration or yaw movements of hydromechanical components, such as crane booms, hydraulic motors on long pipelines, etc.

2. Available versions, type codings

Example:

AC 13 - 1/4 - 50 - ...

Optional extensions (also see section 4.1)
 Order code: K 1/4 = Short version,
 L 1/4 = Long version

Basic type, rated volume and type of connection	Rated volume V_0 (cm ³)	Gas filling pressure $p_{0 max}$ (bar)	Perm. over-press. $p_{4 max}$ (bar)	Highest perm. operating pressure ratio		Mass (weight) (kg)	Adjustm. range for closing valve from ... to (bar)
				$p_{2 max}$ isotherm	$p_{1 max}$ adiabatic		
AC 13 - 1/4 - ...	13	250	500	4:1	3:1	0.3	---
ACS 13 - 1/4 - .../... ¹⁾	13	250	500	4:1	3:1	0.3	20 ... 100 or 80 ... 200 or 180 ... 300
AC 40 - 1/4 - ...	40	250	400	4:1	3:1	0.65	---

¹⁾ The version with the closing valve is used when pressures of $p_{oil 2}$ which are greater than $4 p_0$ occur in the hydraulic circuit. Example: One accumulator is intended to dampen in the low pressure range (low gas preloading) and another one is intended to dampen in the higher pressure range (high gas preloading). Type ACS 13 is selected for the accumulator operating in the lower pressure range and the closing valve is set to a closing pressure $\leq 4 p_0$, under adiabatic stress (constant load change) $\leq 3 p_0$.

3. Additional characteristic data

Nomenclature	Miniature diaphragm accumulator (ball accumulator)
Installation position	Any
Mounting	G 1/4 A ISO 228/1 (BSPP) tapped journal with sealing lip; max. torque approx. 39 Nm
Ambient temperature	- 20 ... + 60°C
Bursting pressure	approx. 4x max. permissible overpressure p_4
Pressure fluid	Hydraulic oil conforming DIN 51524 part 1 to 3; ISO VG 10 to 68 conforming DIN 51519. Viscosity limits: min. approx. 4, max. approx. 1500 mm ² /sec; opt. operation approx. 10 ... 500 mm ² /sec
Operating pressure	Also see selection table, Page 1 p_0 (bar) gas filling pressure (desired), stamped on accumulator housing $p_{0 \max} = 250 \text{ bar}$; $p_{0 \min} = 5 \text{ bar}$ $p_{oil 1}$ (bar) lower operating pressure (oil side), $p_{oil 1 \min} = 1.1 p_0$ $p_{oil 2}$ (bar) upper operating pressure (oil side), $p_{oil 2 \max} = 4 p_0$ (isothermal), $= 3 p_0$ (adiabatic)
Filler gas	Nitrogen, class 4.0
Refill possibility	Apparent, necessary filling fixture on request (section 5)
Δp -Q-curves	

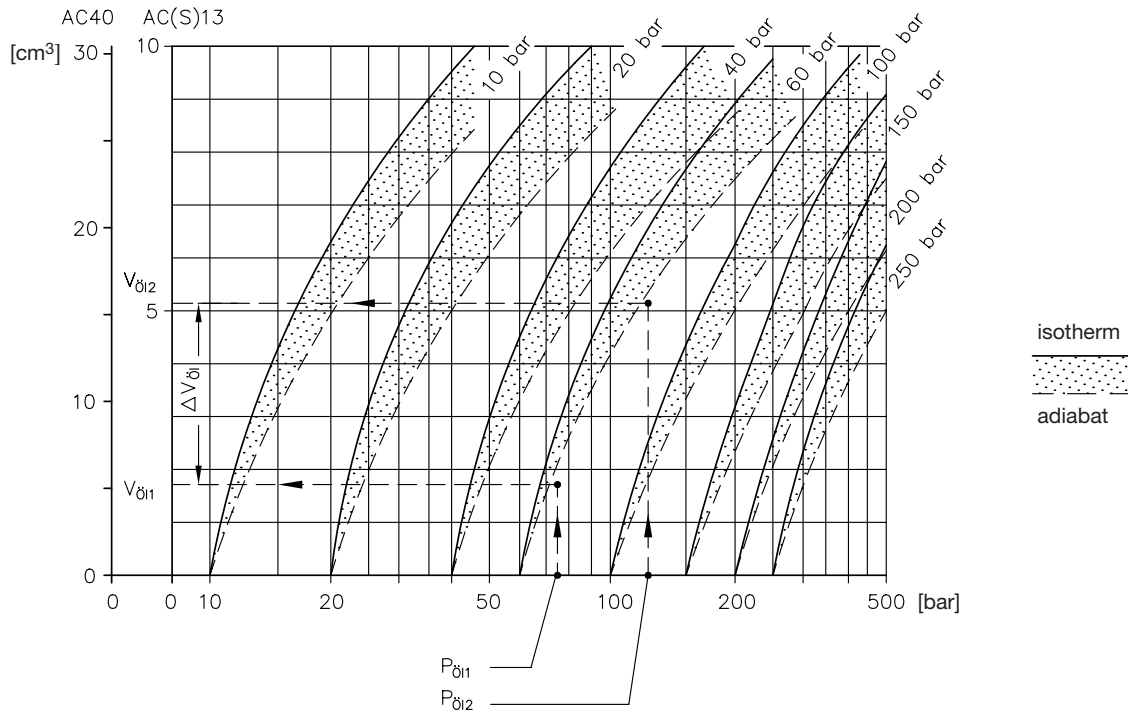

The characteristic represents theoretical recommended limit values only. The available removal volume calculated from the two operating points $p_{oil 2}$ and $p_{oil 1}$ at a given gas filling pressure p_0 is $\Delta V_{oil} = V_{oil 2} - V_{oil 1}$. Largely isothermal behavior can be expected when used for oil leakage compensation. More rapid load changes follow the adiabatic characteristic more closely.

4. Dimensions of units

All dimensions are in mm, subject to change without notice !

Type AC(S) 13

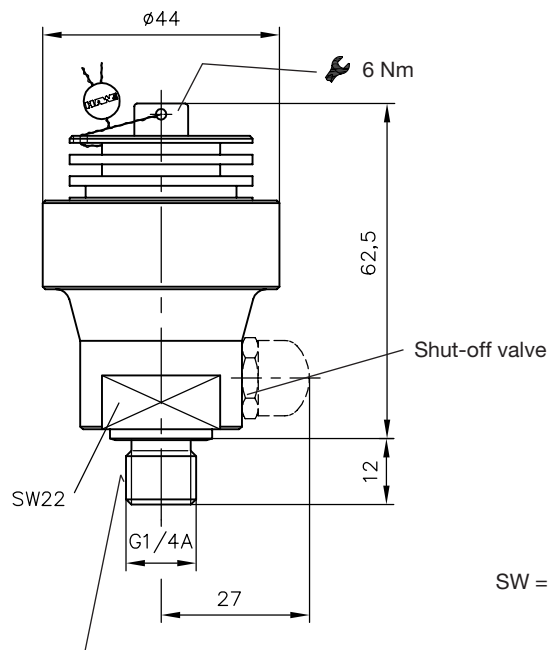

Thread type and -sealing edge conform to type B DIN 3852 page 2

Type AC 40

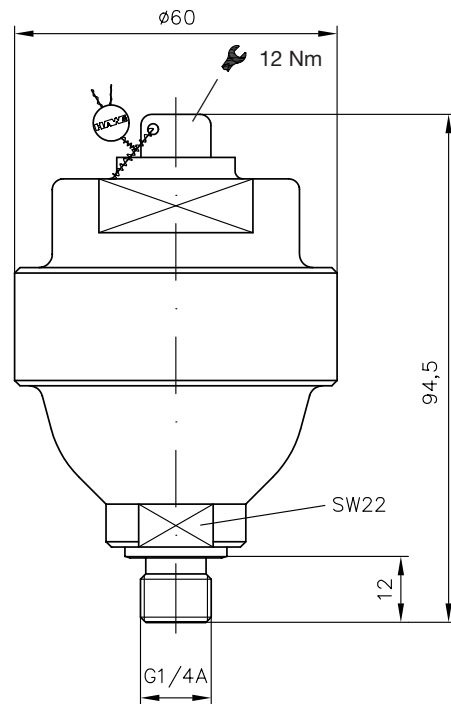

Male threads for all types

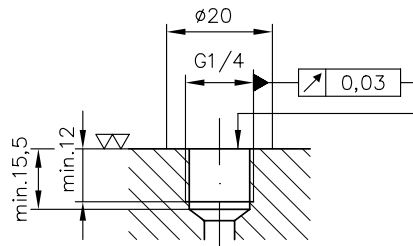

Max. torque approx. 39 Nm

4.1 Extension (optional)

Type K 1/4

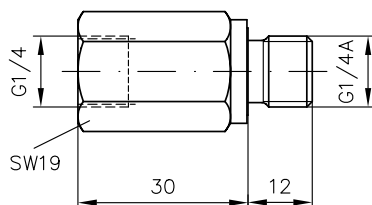

When ordered individually:
 HAWE-No. 6920 210 a
 with sealing G 1/4 NBR
 Mass (weight) approx. 0.06 kg

Type L 1/4

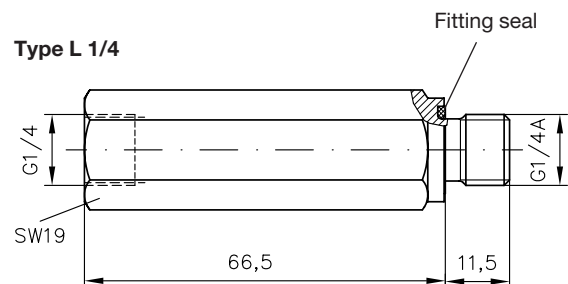

When ordered individually:
 HAWE-No. 6920 210 b
 with sealing G 1/4 NBR
 Mass (weight) approx. 0.1 kg

Attention: For mounting hole of K 1/4 and L 1/4 as well as max. torque, see above !

5. Filling apparatus

For refilling or changing the gas filling pressure.

Important: Connect the nitrogen bottle to the filling apparatus only with pressure reducing valve!
Use only purified nitrogen class 4.0 or 5.0!

Order code for AC(S) 13: **Sk 7571 - F 13**

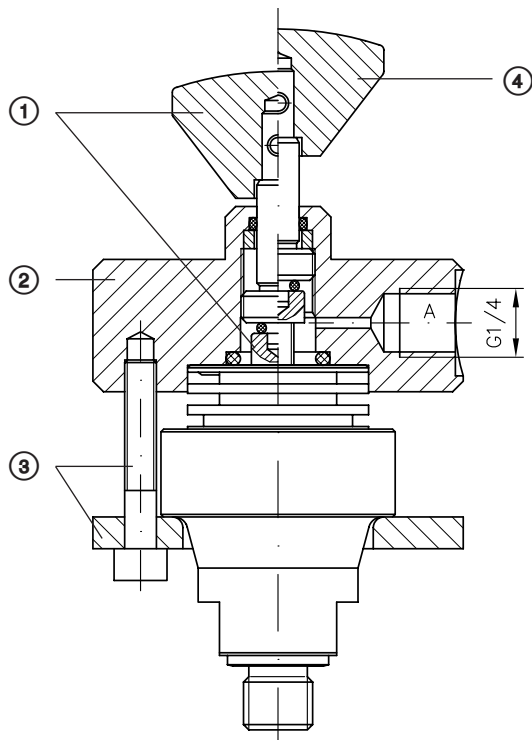

Order code for AC 40: **Sk 7571 - F 40**

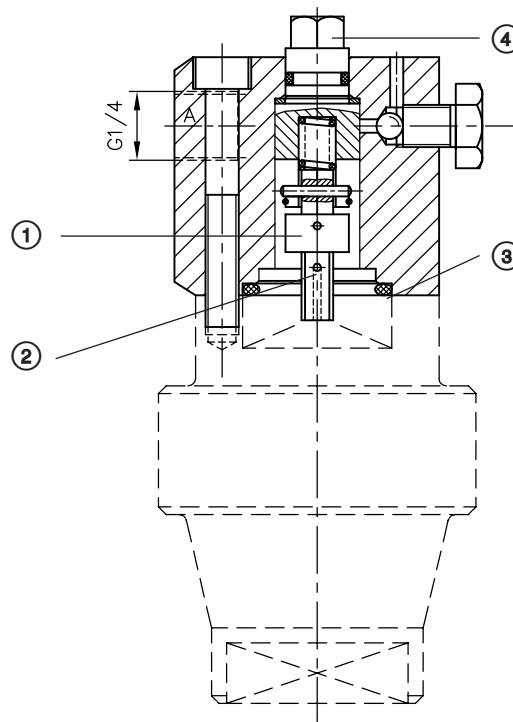

Emptying

1. Screw the spindle of the wing knob into the housing ② as far as it will go and thread the hexagon end into the accumulator venting screw.
2. Hold the accumulator and apparatus together by hand and turn the housing ② clockwise (if necessary) until it is resting on the accumulator.
3. Tighten the counter-ring and screws ③.
4. Unscrew the wing knob anti clockwise = Gas pressure escapes via A

Filling

5. Connect the nitrogen bottle with pressure reducing valve at A and set the desired gas filling pressure on the pressure reducing valve (monitor the press, gauge)
6. Screw in the wing knob clockwise until the accumulator venting screw is in contact.
7. Dismantle the apparatus
8. Tighten the screw

Emptying

Emptying the accumulator: Unscrew the accumulator venting screw ①. Gas escapes via the side venting hole ② after approx. 2 turns of the screw.

Filling

Filling the accumulator: Place the O-ring ③ (23.47x2.62) the recess and screw in the accumulator venting screw until the side venting hole is still free. Screw the filling apparatus to the accumulator. Connect the nitrogen bottle with the pressure reducing valve at A and set the desired gas filling pressure on the pressure reducing valve (monitor the pressure gauge). Screw in the spindle ④ clockwise with a spanner a/f 10 until the accumulator venting screw is in contact. Dismantle the apparatus. Tighten the screw.

6. Note

Do not open the the hydraulic circuit before all hydraulic pressure is discharged from the accumulator. It is therefore essential to note that the accumulator pressure circuit must always be relieved before re-pairs, loosening the fittings, dismantling valves and other service work etc.

Such a note should be placed at the hydraulic system in an easily visible place and should be also included in the operating manual of the system or in the corresponding circuit diagram (DIN 24 346 Paragr. 7.4.7). The pressure circuit can be relieved, for example, via the drain screw in the end plates of the directional control valve banks which are normally used in conjunction with the miniature accumulators (end plate code 2 in D 7470 B/1, sect. 6.2). Also operating one of the directional seated valves, with its absolutely negative overlapping and which is connected to the accumulator, a few times is often sufficient.

However, it must be ensured that any consumer pressure arising here has no effect.